



# The Engineer's Guide to DP Flow Measurement

2020 EDITION



## NOTICE

The Emerson logo is a trademark and service mark of Emerson Electric Co. Rosemount is a mark of one of the Emerson family of companies. All other marks are the property of their respective owners. The contents of this publication are presented for information purposes only, and while effort has been made to ensure their accuracy, they are not to be construed as warranties or guarantees, expressed or implied, regarding the products or services described herein or their use or applicability. The information provided herein is NOT a guarantee for satisfactory results. Emerson reserves the right to modify or improve the designs or specifications of our products at any time without notice.

Copyright © 2020 Emerson. All rights reserved.

No part of this work may be reproduced, stored in a retrieval system, or transmitted in any form or by any means, electronic, mechanical, photocopying, recording or otherwise, without the prior written permission of Emerson.

Emerson Automation Solutions  
6021 Innovation Blvd.  
Shakopee, MN 55379, USA  
Emerson.com

## Introduction

Differential pressure (DP) flow measurement has remained a popular and trustworthy technology for over 100 years due to its range of usability and reliable performance history. The Engineer's Guide to DP Flow Measurement is intended to serve as a reference tool to aid in the selection and use of DP flow products for various applications. This resource offers foundational information for understanding DP flow measurement including basic concepts, theories, and equations. It also explores recommendations and installation best practices to help increase measurement accuracy, optimize plant efficiency, and solve common application challenges.

Topics covered in this guide include:

**Chapter 1 – The DP Flow Meter** provides an overview of the history of DP flow and the basic principles that govern DP flow measurement. It introduces the different components required to measure flow and highlights applications where DP flow measurement can be utilized.

**Chapter 2 – Fluids and Flow Basic Terms and Concepts** discusses the physical properties of fluids and how they interact with one another. This chapter lays the groundwork for understanding the theory behind DP flow meters.

**Chapter 3 – Theory of DP Flow** focuses on derivations and basis for the conservation of energy and mass behind the principals of DP flow. It also traces the pathway from theoretical to practical applications of the DP flow equations for both area meters and averaging pitot tubes.

**Chapters 4, 5, 6 – Gas, Liquid, and Steam Applications** detail common and special applications for the three basic types of fluid as well as recommended Emerson products. These chapters focus on the benefits and challenges associated with applying the DP flow meter as well as special considerations when necessary.

**Chapter 7 – Primary Element Technologies** concentrates on the DP flow primary element in the pipe, which is responsible for creating differential pressure. This chapter focuses on two main types of primary element technologies: area meters and averaging pitot tubes or sampling meters.

**Chapter 8 – Transmitter Technology** discusses how the variables critical to the DP flow equation are measured, converted into communication signals, and relayed to the control system. This chapter provides preliminary guidance for the specification and selection of a transmitter.

**Chapter 9 – Rosemount Primary Elements and Flow Meters** provides an overview of Emerson's Rosemount DP flow products, benefits, and uses.

**Chapter 10 – DP Flow Meter Installation** offers general installation guidelines and best practices for bringing DP flow meters into service.

**Chapter 11 – Calibration, Maintenance, and Troubleshooting** discusses the basic methodology for the calibration, maintenance, and troubleshooting of transmitters, primary elements, and flow meters to maintain accurate flow measurement.

**Chapters 12, 13, 14 – Engineering Data, Pipe Data, and Conversions and Equivalents** contain reference information related to standard specifications, material properties, and physical constants of various fluids. It also includes conversion and equivalents tables.

## Acknowledgments

*The Engineer's Guide to DP Flow Measurement* is the result of years of effort from individuals around the world, and the following deserve recognition for contributing their knowledge and experience to this handbook:

Alena Johnson – Global Product Manager

Alex Novak – Global Product Manager

Allison Hansen – Global Integrated Marketing Manager

Amy Johnson – Director of Product Management

Brett Morrison – Director of Product Management, North America

Connor Oberle – Global Product Manager

Dan Cychosz – Manager, Product Management

Dave Mesnard – Principle Engineer

Emily Saopraseuth – Director of Product Management

Feroze Hamid – Director of Product Management, Asia Pacific

Greg Strom – Director of Engineering

Jim Linahan – Business Development Manager

John Van Gorsel – Product Manager, Europe

Katie Stahl – Global Product Manager

Kevin Branger – Senior Principal Application Engineer

Mark Fuhrman – DP Flow Specialist

Mark Menezes – Canada Manager, Measurement

Mark Sagstetter – Business Development Manager

Rachel Engelhardt – DP Flow Specialist

Satnam Singh – Product Manager, MEA

Scott Peterson – Business Development Manager

Vern Binger – DP Flow Specialist

Zhao Li – Product Manager, Asia Pacific

Of course, putting that knowledge into a professional document is no small task. A special thank you to the design and technical writing teams for the experience, guidance, and attention to detail that you brought to this guide:

Annette Hartman – Graphic Artist, M45 Marketing Services

Julie Walker – Technical Writer, Words Tell A Story

Finally, thank you to all the unnamed contributors and all of the Emerson DP flow users.

## Chapter 1 — The DP Flow Meter

1.1	Introduction . . . . .	2
1.2	History of DP Flow . . . . .	2
1.2.1	The Bernoulli Equation . . . . .	2
1.2.2	The Reynolds Number . . . . .	3
1.3	Differential Pressure and the DP Flow Meter . . . . .	4
1.4	DP Flow Basics . . . . .	5
1.4.1	What is Flow? . . . . .	5
1.4.2	Principles of Flow Metering . . . . .	5
1.4.3	The Pitot Tube . . . . .	7
1.4.4	The DP Flow Meter . . . . .	7
1.4.5	The Primary Element . . . . .	8
1.5	DP Flow Measurement Applications . . . . .	9
1.6	DP Flow Meter Installations: Traditional vs. Integrated . . . . .	10
1.6.1	Traditional DP Flow Meter . . . . .	10
1.6.2	Integrated DP Flow Meter . . . . .	10
1.6.3	A Comparison — Traditional Versus Integrated DP Flow Meters . . . . .	11
1.7	Alternative Flow Technologies . . . . .	11
1.7.1	Coriolis . . . . .	12
1.7.2	Magnetic . . . . .	12
1.7.3	Vortex . . . . .	12
1.7.4	Ultrasonic . . . . .	12

## Chapter 2 — Fluids and Flow Basic Terms and Concepts

2.1	Introduction . . . . .	14
2.2	Physical Fluid Properties . . . . .	14
2.2.1	Mass, Force, and Weight . . . . .	14
2.2.2	Density . . . . .	15
2.2.3	Specific Weight and Specific Gravity . . . . .	16
2.2.4	Liquid Mixtures . . . . .	17
2.2.5	Pressure . . . . .	19
2.2.6	Temperature . . . . .	20
2.2.7	The Ideal and Real Gas Laws . . . . .	21
2.2.7.1	<i>The Mole and Avogadro's Number</i> . . . . .	22
2.2.7.2	<i>The Equation of State</i> . . . . .	23
2.2.7.3	<i>Gas Compressibility</i> . . . . .	24
2.2.8	Gas Mixtures . . . . .	25
2.2.8.1	<i>Compressibility of a Gas Mixture</i> . . . . .	26
2.2.9	Humidity . . . . .	30
2.2.10	Gas Specific Heats and the Isentropic Ratio . . . . .	30
2.2.11	Viscosity . . . . .	31
2.3	Fluid Flow Basics . . . . .	34
2.3.1	Velocity . . . . .	34
2.3.2	Actual Volumetric Flow . . . . .	34
2.3.3	Mass Flow . . . . .	34
2.3.4	Standard Volumetric Flow . . . . .	35
2.4	DP Flow Basic Terms . . . . .	35
2.4.1	DP Flow Components . . . . .	35
2.4.2	Differential Pressure . . . . .	35

2.4.3	DP Flow Meter Sizing . . . . .	36
2.4.4	Pipe Blockage by the DP Flow Meter . . . . .	36
2.4.5	Discharge Coefficient . . . . .	37
2.4.6	Flow Coefficient . . . . .	37
2.4.7	Flow and DP Turndown . . . . .	37
2.4.8	Accuracy . . . . .	38
2.5	Applicable Flow Meter Standards . . . . .	38

## Chapter 3 — Theory of DP Flow

3.1	Introduction . . . . .	40
3.2	Energy of a Fluid in Motion . . . . .	40
3.2.1	The Kinetic Energy of a Fluid . . . . .	40
3.2.2	The Body Energy of a Fluid . . . . .	41
3.2.3	The Pressure Energy of a Fluid . . . . .	41
3.2.4	The Internal Energy of a Fluid . . . . .	41
3.2.5	Combining the Fluid Energy Forms . . . . .	41
3.3	Specific Forms of the Fluid Energy Equation . . . . .	42
3.4	The Energy Equation for the DP Flow Meter . . . . .	43
3.4.1	Deriving the Theoretical Area DP Flow Meter Equation . . . . .	43
3.4.2	Deriving the Theoretical Pitot Tube DP Flow Meter Equation . . . . .	44
3.5	Theoretical and True Fluid Flow Equations . . . . .	45
3.6	The Practical DP Flow Equations . . . . .	46
3.6.1	The Units Conversion Factor, N . . . . .	46
3.6.2	Standard Volume Flow . . . . .	47
3.7	Reynolds Number and the Velocity Profile . . . . .	50
3.7.1	The Velocity Profile . . . . .	51
3.7.2	Kinetic Energy Coefficient . . . . .	52
3.7.3	Calculating the Reynolds Number . . . . .	53
3.7.4	Non-Circular Pipes or Ducts . . . . .	53
3.8	Developed and Undeveloped Flows . . . . .	54
3.9	Compressible Flow . . . . .	56
3.9.1	Isentropic Expansion Factor . . . . .	56
3.9.2	Non-Isentropic Expansion Factor . . . . .	57
3.9.3	The Expansion Factor for the Averaging Pitot Tube . . . . .	59
3.10	Applicable Flow Meter Standards . . . . .	60
3.11	Additional Information . . . . .	60

## Chapter 4 — Gas Applications

4.1	Introduction . . . . .	62
4.2	Common Applications . . . . .	62
4.2.1	Natural Gas . . . . .	62
4.2.2	Emissions Measurement . . . . .	64
4.2.3	Flare Gas . . . . .	64
4.2.4	Duct and Blower Applications . . . . .	65
4.2.4.1	Combustion Air Flow . . . . .	66
4.2.4.2	Heating Ventilation and Air Conditioning (HVAC) . . . . .	67
4.2.4.3	Scrubbers . . . . .	67
4.2.4.4	Air Ventilation in Mines . . . . .	68
4.2.5	Furnace Fuel . . . . .	69
4.2.6	Compressed Air . . . . .	69

<b>4.2.7 Dissolved Air Flotation Cell</b> .....	<b>70</b>
4.3 Special Applications .....	71
4.3.1 Wet Gas .....	71
4.4 Gas Density .....	73
4.4.1 Gas Expansion Factor .....	73
4.5 Issues of Gas Composition .....	74
4.5.1 Natural Gas Composition .....	74
4.5.2 Compensating for Humidity .....	74
4.5.2.1 Saturated and Unsaturated Gas .....	74
4.5.2.2 Calculating the Density of Humid Air .....	74
4.5.2.3 Correcting the Flow Meter for Humidity .....	75
4.6 Applicable Flow Meter Standards .....	75
4.6.1 AGA Report No. 3 .....	76
4.6.2 ISO 5167 .....	76
4.6.3 ASME MFC Documents .....	76
4.6.4 AGA Report No. 3 .....	77
4.6.5 GOST 30319 .....	77
4.6.6 ASME B31.8 .....	77
4.6.7 Other Standards .....	77
4.7 Additional Information .....	77

## Chapter 5 — Liquid Applications

5.1 Introduction .....	80
5.2 Common Applications .....	80
5.2.1 Cooling Water .....	80
5.2.2 Boiler Systems .....	81
5.2.2.1 Boiler Feedwater .....	81
5.2.2.2 Condensate System .....	83
5.2.3 Commercial and Residential Potable Water .....	83
5.2.4 Hydrocarbon and Custody Transfer Applications .....	84
5.2.4.1 Downstream (Refining) .....	84
5.2.4.2 Midstream (Transportation and Storage) .....	85
5.2.4.3 Upstream (Production) .....	86
5.2.4.4 Custody Transfer (Fiscal Metering) .....	86
5.2.5 Hydrocarbon Recovery — Water Injection .....	87
5.2.6 Measuring Natural Water (Rivers, Lakes) .....	87
5.2.7 Large Pipeline and Penstock Applications .....	88
5.2.8 Cryogenic Flow Applications .....	89
5.2.9 Slurries .....	90
5.3 Special Applications .....	91
5.3.1 Underground and Vault Installations .....	91
5.4 Density Requirements .....	91
5.5 Challenges and Considerations for Use .....	92
5.5.1 Entrained Gases or Solids .....	92
5.6 Applicable Flow Meter Standards .....	92

## Chapter 6 — Steam Applications

6.1	Introduction	94
6.1.1	Benefits of Measuring Steam Using Differential Pressure (DP) Flow	94
6.2	Steam Types and Parameters	94
6.2.1	The Mollier Diagram	94
6.2.2	Saturated Steam	95
6.2.2.1	<i>The Saturation Line</i>	95
6.2.2.2	<i>Finding the Density</i>	97
6.2.2.3	<i>Steam Enthalpy and the Flow of Energy</i>	97
6.2.3	Superheated Steam	97
6.2.3.1	<i>Finding the Density</i>	99
6.2.3.2	<i>Enthalpy</i>	99
6.2.3.3	<i>The Rankine Cycle and Steam Turbines</i>	99
6.2.4	Wet (Quality) Steam	99
6.2.4.1	<i>Finding the Density</i>	100
6.2.4.2	<i>Finding the Enthalpy</i>	100
6.2.4.3	<i>Calculating the Equivalent Dry Steam Flow Rate</i>	100
6.3	Measuring the Flow of Steam Using a DP Flow Meter	102
6.3.1	Orifice Meter in Horizontal Pipes	102
6.3.2	Orifice Meter in Vertical Pipes	103
6.3.3	The Averaging Pitot Tube in Horizontal Steam Pipes	103
6.3.4	The Averaging Pitot Tube in Vertical Steam Pipes	104
6.3.5	The Integrally Mounted DP Flow Meter	105
6.4	Options for DP Transmitter Connections	106
6.5	Maintaining Wet Legs	106
6.6	Saturated Steam Applications	107
6.6.1	Process Heating	107
6.6.2	District Heating	107
6.6.3	Pulp and Paper	108
6.7	Superheated Steam Applications	109
6.7.1	Thermal Power Plants	109
6.7.2	Turbine Steam Flow	109
6.7.3	Geothermal Energy	110
6.7.4	Concentrated Solar Energy	112
6.8	Wet (Quality) Steam Applications	112
6.8.1	Steam Injection for Enhanced Oil Recovery	112
6.9	Applicable Flow Meter Standards	113

## Chapter 7 — Primary Element Technologies

7.1	Introduction	116
7.2	DP Primary Element Technology Types	116
7.2.1	Area DP Meter	116
7.2.2	Sampling DP Meter	116
7.2.3	Non-Proprietary and Proprietary DP Flow Meters	117
7.3	DP Flow Meter Selection	117
7.3.1	Installation	119
7.3.2	Fluid Types	119
7.3.3	Pressure and Temperature Requirements	120



7.3.4	Flow Meter Performance Review .....	120
	7.3.4.1 <i>Repeatability</i> .....	121
	7.3.4.2 <i>Linearity</i> .....	121
	7.3.4.3 <i>Accuracy</i> .....	121
	7.3.4.4 <i>Reproducibility</i> .....	122
	7.3.4.5 <i>Turndown</i> .....	122
	7.3.4.6 <i>Flow Coefficient</i> .....	122
7.3.5	Installation Requirements .....	124
	7.3.5.1 <i>Straight Piping Requirements</i> .....	124
	7.3.5.2 <i>Determining the Primary Meter Location and Orientation</i> ...	125
	7.3.5.3 <i>New Installation or Retrofit</i> .....	125
	7.3.5.4 <i>Sizing an Area DP Flow Meter</i> .....	126
7.3.6	Costs .....	126
	7.3.6.1 <i>Purchased Costs</i> .....	126
	7.3.6.2 <i>Installation Costs</i> .....	126
	7.3.6.3 <i>Operating and Maintenance Costs</i> .....	127
7.4	DP Flow Primary Element Design and Technology .....	127
	7.4.1 Orifice Plates .....	128
	7.4.1.1 <i>Concentric Orifice Maker</i> .....	128
	7.4.1.2 <i>Special Orifice Plate Designs</i> .....	130
	7.4.1.3 <i>Conditioning Orifice Plate</i> .....	131
	7.4.2 Venturi Tube .....	133
	7.4.2.2 <i>Short-Form Venturi Tube</i> .....	133
	7.4.2.3 <i>Universal Venturi Tube</i> .....	133
	7.4.3 Flow Nozzle .....	134
	7.4.3.1 <i>Non-Proprietary Nozzle Designs</i> .....	134
	7.4.3.2 <i>Venturi Nozzle</i> .....	135
	7.4.4 Wedge Primary Element .....	136
	7.4.5 Cone Meter .....	137
	7.4.6 Averaging Pitot Tube .....	138
	7.4.6.1 <i>Sampling the Velocity Profile</i> .....	139
	7.4.6.2 <i>Averaging Pitot Tube Low or Reference Pressure</i> .....	140
	7.4.6.3 <i>Averaging Pitot Tube Pressure Coefficients and the Flow Coefficient</i> .....	142
	7.4.6.4 <i>Blockage vs. the Averaging Pitot Tube Flow Coefficient</i> ....	143
	7.4.6.5 <i>Sizing the Averaging Pitot Tube</i> .....	144
7.5	Applicable Flow Meter Standards .....	146
7.6	Additional Information .....	146

## Chapter 8 — Transmitter Technology

8.1	Introduction .....	148
8.2	Main Components .....	148
	8.2.1 Process Connection .....	148
	8.2.2 Sensor .....	148
	8.2.3 Module .....	149
	8.2.4 Housing .....	149
	8.2.5 Electronics .....	149
8.3	Principles of Capacitive and Piezoresistive Pressure Measurement .....	149
	8.3.1 Capacitive Sensor .....	150
	8.3.2 Piezoresistive Strain Gauge Sensor .....	151

8.4	Transmitter Types . . . . .	151
8.4.1	Single Variable DP Transmitters . . . . .	152
8.4.2	Multivariable Transmitters . . . . .	153
8.5	Process Connections . . . . .	155
8.5.1	Instrument Flanges . . . . .	155
8.5.2	DP Manifolds . . . . .	155
8.5.3	Primary Elements and Integrated DP Flow Meters . . . . .	157
8.5.4	Seals . . . . .	157
8.6	DP Transmitter Ranges . . . . .	158
8.6.1	DP Transmitter Rangedown . . . . .	158
8.6.2	Flow and DP Turndown . . . . .	159
8.7	Transmitter Specifications . . . . .	160
8.7.1	Performance Specifications . . . . .	160
8.7.1.1	<i>Reference Accuracy</i> . . . . .	161
8.7.1.2	<i>Ambient Temperature Effects</i> . . . . .	161
8.7.1.3	<i>Line Pressure Effects</i> . . . . .	161
8.7.1.4	<i>Stability</i> . . . . .	161
8.7.2	Physical Specifications . . . . .	162
8.7.3	Functional Specifications . . . . .	162
8.7.4	Transmitter Costs . . . . .	163
8.8	Communication . . . . .	163
8.8.1	Analog Signals . . . . .	163
8.8.2	Digital Signals . . . . .	164
8.8.2.1	<i>Advantages of Digital Communication</i> . . . . .	164
8.8.2.2	<i>HART</i> . . . . .	164
8.8.2.3	<i>FOUNDATION Fieldbus</i> . . . . .	164
8.8.2.4	<i>PROFIBUS</i> . . . . .	165
8.8.2.5	<i>Modbus</i> . . . . .	165
8.8.2.6	<i>WirelessHART</i> . . . . .	165
8.9	Safety . . . . .	165
8.9.1	Safety Instrumented Systems . . . . .	165
8.9.2	Safety Integrity Level . . . . .	166
8.10	Installation Considerations . . . . .	166
8.10.1	Process Temperature . . . . .	167
8.10.2	Ambient Temperature . . . . .	167
8.10.3	Process Pressure . . . . .	167
8.10.4	Direct Mount and Remote Mount Configurations . . . . .	167
8.10.5	Additional Considerations . . . . .	168
8.11	Configuration . . . . .	168
8.11.2	Device Configuration . . . . .	169
8.11.2.1	<i>Units of Measure</i> . . . . .	169
8.11.2.2	<i>Range Points</i> . . . . .	169
8.11.2.3	<i>Zero Trim</i> . . . . .	169
8.11.2.4	<i>Damping</i> . . . . .	169
8.11.2.5	<i>Low Flow Cutoff</i> . . . . .	170
8.11.3	Flow Configuration . . . . .	170
8.12	Calibration . . . . .	170
8.13	Applicable Flow Meter Standards . . . . .	171
8.14	Additional Information . . . . .	171

## Chapter 9 — Rosemount Primary Elements and Flow Meters

9.1	Introduction . . . . .	174
9.2	Rosemount Integrated Flow Meter Portfolio . . . . .	174
	9.2.1 DP Flow Meter System. . . . .	174
	9.2.2 Rosemount Integrated Flow Meter Versatility. . . . .	174
	9.2.3 Benefits of the Rosemount Integrated Flow Meter . . . . .	176
	9.2.4 Flow Meter Sizing and Configuration . . . . .	177
	9.2.5 DP Flow Meter System Performance . . . . .	178
9.3	Rosemount Annubar Flow Meter . . . . .	178
	9.3.1 Advantages of the Annubar Primary Element. . . . .	178
	9.3.2 Annubar Flow Meters . . . . .	179
	9.3.3 Annubar Primary Element: Performance by Design . . . . .	180
	9.3.4 Rosemount 485 Annubar Primary Element. . . . .	180
	9.3.5 Rosemount 405A Annubar Primary Element. . . . .	185
	9.3.6 Rosemount 585 Annubar Primary Element. . . . .	186
	9.3.7 Performance. . . . .	187
9.4	Conditioning Orifice Plate . . . . .	187
	9.4.1 Advantages of the Rosemount Conditioning Orifice Plate . . . . .	188
	9.4.2 Rosemount Conditioning Orifice Plate vs. the Multi-Hole Orifice Plate . . . . .	188
	9.4.3 Conditioning Orifice Plate Flow Meter Products . . . . .	189
	9.4.4 Rosemount 405C Compact Conditioning Orifice Plate Flow Meter. . . . .	189
	9.4.5 Rosemount 9295 Process Flow Meter . . . . .	191
	9.4.6 Rosemount 1595 Conditioning Orifice Plate . . . . .	193
	9.4.7 Conditioning Orifice Plate Performance. . . . .	193
9.5	Rosemount 1195 Integral Orifice Primary Element . . . . .	195
	9.5.1 Advantages of the Rosemount Integral Orifice Plate . . . . .	195
	9.5.2 Integrated DP Flow Measurement for Small Pipes . . . . .	196
	9.5.3 A Range of Orifice Bores for Every Application . . . . .	196
	9.5.4 Performance. . . . .	196
9.6	Traditional Orifice Plate Products . . . . .	197
	9.6.1 Rosemount 405P Compact Orifice Plate DP Flow Meter . . . . .	197
	9.6.2 Rosemount 1495 Orifice Plate . . . . .	197
	9.6.3 Performance. . . . .	198
9.7	Rosemount Transmitters . . . . .	198
	9.7.1 Rosemount 2051C, 3051C, and 3051S Transmitters. . . . .	198
	9.7.2 Rosemount 3051S MultiVariable Transmitter. . . . .	199
	9.7.3 Rosemount 4088 MultiVariable Transmitter. . . . .	200
	9.7.4 Rosemount Coplanar Platform . . . . .	200
	9.7.5 Rosemount Performance . . . . .	201
	9.7.5.1 <i>Manufacturing Processes</i> . . . . .	202
	9.7.5.2 <i>Rosemount Transmitter Accuracy</i> . . . . .	203
	9.7.6 Multivariable Flow Measurement . . . . .	204
	9.7.7 Rosemount Advanced Diagnostics . . . . .	206
	9.7.7.1 <i>Process Intelligence</i> . . . . .	206
	9.7.7.2 <i>Plugged Impulse Line</i> . . . . .	206
	9.7.7.3 <i>Loop Integrity</i> . . . . .	207
	9.7.7.4 <i>Additional Diagnostics</i> . . . . .	207
9.8	Additional Information . . . . .	208

## Chapter 10 — DP Flow Meter Installation

10.1	Introduction .....	210
10.2	DP Flow Meter Installation Essentials .....	210
10.2.1	Safety Concerns .....	210
10.2.2	Preventing Flow Meter Damage .....	210
10.2.2.1	<i>Mechanical Damage</i> .....	210
10.2.2.2	<i>Process-Related Damage</i> .....	211
10.2.2.3	<i>Flow Meter Materials</i> .....	211
10.2.2.4	<i>Ambient Conditions</i> .....	211
10.2.3	Optimizing Flow Meter Performance .....	212
10.2.3.1	<i>Measuring the Pipe</i> .....	212
10.3	Installation Planning .....	213
10.3.1	Application Type .....	213
10.3.2	Primary Element Mounting .....	213
10.3.2.1	<i>Spool-Mounted Meter</i> .....	213
10.3.2.2	<i>Wafer-Mounted Meter</i> .....	214
10.3.2.3	<i>Insert-Mounted Meter</i> .....	214
10.3.3	DP or Flow Transmitter Mounting .....	215
10.3.3.1	<i>Direct Mount</i> .....	215
10.3.3.2	<i>Remote Mount</i> .....	215
10.3.4	Temperature Limits .....	216
10.3.5	Vibration Limits .....	216
10.3.6	Process Fluid .....	217
10.3.6.1	<i>Particulate Accumulation</i> .....	217
10.3.6.2	<i>Gas Entrapment for a Liquid Flow</i> .....	218
10.3.6.3	<i>Liquid Accumulation for a Gas Flow</i> .....	218
10.3.7	Heat Tracing .....	219
10.3.8	Steam Applications .....	219
10.3.9	Wiring .....	219
10.3.9.1	<i>2-wire vs. 4-wire</i> .....	219
10.3.9.2	<i>Types of Wire</i> .....	220
10.3.9.3	<i>Conduits and Cable Trays</i> .....	220
10.3.9.4	<i>Transient Surge Protection</i> .....	220
10.3.9.5	<i>Grounding</i> .....	221
10.4	Installation Location .....	221
10.4.1	Rosemount 485, 405A, and 585 Annubar Primary Elements .....	224
10.4.2	Rosemount 1595, 405C, and 9295 Conditioning Orifice Plates .....	224
10.4.3	Rosemount 1495 and 405P Traditional Orifice Plates .....	224
10.4.4	Rosemount 1195 Integral Orifice Primary Element .....	225
10.4.5	Flow Straighteners .....	225
10.5	Installation Orientation .....	225
10.5.1	Fluid Type .....	225
10.5.1.1	<i>Gas Applications</i> .....	226
10.5.1.2	<i>Liquid Applications</i> .....	226
10.5.1.3	<i>Steam Applications</i> .....	226
10.5.2	Annubar Primary Elements .....	227
10.5.2.1	<i>Flow Meter Orientation to the Upstream Fitting</i> .....	228
10.5.3	Conditioning Orifice Plates .....	228
10.5.4	Traditional Orifice Plates .....	229
10.6	Impulse Piping for Remote Mount Applications .....	229

10.7	Flow Meter Installation . . . . .	231
10.7.1	Flow Direction Arrow . . . . .	231
10.7.2	Annubar Primary Element Alignment . . . . .	231
10.7.3	Orifice Plate Alignment . . . . .	232
10.7.3.1	<i>Rosemount 405 Compact Platform . . . . .</i>	<i>232</i>
10.7.3.2	<i>Rosemount 1195 Integral Orifice Primary Element . . . . .</i>	<i>232</i>
10.7.3.3	<i>Rosemount 1495 and 1595 . . . . .</i>	<i>232</i>
10.7.4	Transmitter Installation . . . . .	233
10.8	Special Installation Considerations . . . . .	233
10.8.1	Hot Tapping . . . . .	233
10.8.2	Duct Mount . . . . .	234
10.8.3	Stack/Flue Gas . . . . .	235
10.8.4	Cryogenic Fluids . . . . .	236
10.8.5	Steam Applications . . . . .	237
10.8.5.1	<i>Direct Mounting for Steam Service . . . . .</i>	<i>238</i>
10.8.5.2	<i>Installation Requirements for High Temperature Steam Service . . . . .</i>	<i>238</i>
10.8.6	Flow Meter Installations for High Temperature and Pressure . . . . .	239
10.8.7	Orifice Plate Installations for High Pressure and Temperature . . . . .	239
10.9	In-Situ Calibration Using Pitot Traverse . . . . .	240
10.10	Commissioning . . . . .	242
10.10.1	DP Flow Meter Commissioning Procedure . . . . .	243
10.11	Installation Checklist . . . . .	244
10.12	Additional Information . . . . .	245

## Chapter 11 — Calibration, Maintenance, and Troubleshooting

11.1	Introduction . . . . .	248
11.2	Safety First . . . . .	248
11.2.1	Know the Process Fluid and Conditions . . . . .	248
11.2.2	Wear Proper Personal Protection Equipment (PPE) . . . . .	248
11.2.3	Understand the Proper Procedures before Starting Work . . . . .	248
11.2.4	Bleed or Vent Fluids . . . . .	248
11.3	Calibration . . . . .	248
11.3.1	Calibration and Verification . . . . .	249
11.3.2	Uncalibrated and Calibrated Performance . . . . .	249
11.3.3	Flow Meter Calibration Systems . . . . .	250
11.3.3.1	<i>Gravimetric Calibration Systems . . . . .</i>	<i>250</i>
11.3.3.2	<i>Reference or Working Standard Meter Systems . . . . .</i>	<i>251</i>
11.3.3.3	<i>Uncertainty for the Laboratory and the Test Meter . . . . .</i>	<i>251</i>
11.3.4	Reynolds Number Operating Range . . . . .	251
11.3.5	Calibration and Verification of the DP Transmitter . . . . .	252
11.3.5.1	<i>Sensor Trim . . . . .</i>	<i>253</i>
11.3.5.2	<i>Zero Trim . . . . .</i>	<i>253</i>
11.3.5.3	<i>Analog Trim . . . . .</i>	<i>253</i>
11.3.5.4	<i>Bench and In-Situ Calibration . . . . .</i>	<i>253</i>
11.3.6	The DP Transmitter Calibration Equipment and Standards . . . . .	254
11.3.7	Calibration Procedure . . . . .	254
11.3.8	Calibration Frequency . . . . .	255
11.3.9	Pressure Transmitter Calibration . . . . .	256
11.3.10	Temperature Transmitter Calibration . . . . .	256
11.3.11	Calibrating the Multivariable Transmitter . . . . .	257

11.4	Maintenance .....	257
11.4.1	Annubar Primary Element Maintenance .....	257
11.4.1.1	Inspection .....	257
11.4.1.2	Cleaning .....	257
11.4.1.3	Annubar Primary Element Geometry Verification .....	258
11.4.1.4	Leak-Checking the Annubar Primary Element .....	258
11.4.2	Area Meter Primary Maintenance .....	258
11.4.2.1	Inspection .....	259
11.4.2.2	Cleaning .....	259
11.4.2.3	Orifice Bore Condition and Measurement .....	260
11.4.2.4	Impulse-Piping Inspection and Leak Checking .....	260
11.4.3	DP Transmitter Maintenance .....	260
11.4.4	Commissioning the DP Flow Meter .....	261
11.5	Troubleshooting .....	261
11.5.1.1	Verifying the DP Primary Element and Installation .....	261
11.5.1.2	Verifying the DP Transmitter .....	262
11.5.2	What Is the Nature of the Problem? .....	262
11.5.2.1	Meter Does Not Read Flow .....	262
11.5.2.2	Meter Reads Higher or Lower than Expected .....	263
11.5.2.3	Meter Signal Is Noisy .....	264
11.5.2.4	Meter Reading Does Not Change with the Flow Rate .....	265
11.5.2.5	Calculating the Flow Rate Manually .....	265
11.5.2.6	Collect Application Data .....	265
11.5.2.7	Calculate the Flow Rate .....	266
11.6	DP Flow Meter Operation Checklist .....	267
11.7	Additional Information .....	269

## Chapter 12 — Engineering Data

12.1	Standard Specifications for Pressure-Retaining Materials .....	272
12.2	Material Properties for Pressure-Containing Components .....	279
12.3	Physical Constants of Hydrocarbons .....	281
12.4	Specific Heat Ratio .....	284
12.5	Physical Constants of Various Fluids .....	285
12.6	Properties of Water .....	288
12.7	Properties of Saturated Steam .....	289
12.8	Properties of Superheated Steam .....	298

## Chapter 13 — Pipe Data

13.1	Pipe Engagement .....	308
13.2	Carbon and Alloy Steel — Stainless Steel .....	308
13.3	American Pipe Flange Dimensions .....	317
13.4	Cast Steel Flange Standards .....	322

## Chapter 14 — Conversions and Equivalents

14.1	Length Equivalents	330
14.2	Whole Inch to Millimeter Equivalents	330
14.3	Fractional Inch to Millimeter Equivalents	331
14.4	Additional Fractional Inch to Millimeter Equivalents	332
14.5	Area Equivalents	334
14.6	Volume Equivalents	334
14.7	Volume Rate Equivalents	334
14.8	Mass Conversion — Pounds to Kilograms	335
14.9	Pressure Equivalents	335
14.10	Pressure Conversion — psi to Bar	336
14.11	Temperature Conversion Formulas	337
14.12	Temperature Conversions	338
14.13	API and Baumé Gravity Tables and Weight Factors	341
14.14	Other Useful Conversions	343
14.15	Metric Prefixes and Suffixes	344

## Appendix

Trademarks	345
Glossary	346







# The DP Flow Meter

	Topic	Page
1.1	Introduction	2
1.2	History of DP Flow	2
1.3	Differential Pressure and the DP Flow Meter	4
1.4	DP Flow Basics	5
1.5	DP Flow Measurement Applications	9
1.6	DP Flow Meter Installations: Traditional vs. Integrated	10
1.7	Alternative Flow Technologies	11

## 1.1 Introduction

Differential pressure (DP) flow measurement is one of the most common technologies for measuring flow in a closed pipe. DP flow meters determine the flow rate from the pressure differential between the upstream (high) side and downstream (low) side of the DP flow primary element.

Some of the reasons for the technology's longevity are:

- The well-known laws of fundamental physics, particularly fluid dynamics and hydraulics, have guided DP flow technology.
- The long history of the traditional DP flow meter has provided extensive performance data and application experience.
- Over 100 years of manufacturing DP flow meter technology has provided a large and diverse catalog of both general and application-specific DP flow primary elements, instrumentation, and installation choices using the latest electronic and digital technologies.
- DP flow meter products have continued to improve, and current technologies achieve high performance and reliability.

DP flow measurement is often accomplished by assembling two or more separate components that are sized and configured to work together. While some other flow meter technologies provide a simple solution through inherently integrated components, DP flow meters often provide a greater utility to the user. Specification, configuration, and versatility of each DP flow meter component can yield optimal solutions to complex flow applications when other, simpler technologies fall short. The technology is still in demand today due to its flexibility, ease of use, and rich history.

## 1.2 History of DP Flow

The flow of fluids has always been a part of human survival. Ancient Egyptians made predictions of harvests based on the relative level of spring floods of the Nile. Centuries later, as Romans engineered aqueducts to convey water into their cities for sustenance, baths, and sanitation, the need to monitor steady flow became important. Roman technicians used flow through an orifice or the welling of water over obstructions to roughly gauge flow rates.

Newton's discovery of gravitation in 1687 advanced flow metering to a predictable and repeatable measurement. This concept enabled physicists and mathematicians to begin formulating a broad range of theories around fluid motion and force. This in turn helped develop a range of instruments that could quantify flow rates.

### 1.2.1 The Bernoulli Equation

Swiss mathematician Daniel Bernoulli (1700-1782), whose study of hydrodynamics (i.e., forces acting on or exerted by fluids) centered on the principle of the conservation of energy, provided the first key breakthrough in the development of the theory behind flow measurement. Bernoulli experimented with fluid pressure measurement and the relationship between pressure and flow. This understanding led to the development of what became known as Bernoulli's principle, which states that an increase in the velocity of the fluid results in a simultaneous decrease in the fluid pressure (i.e., potential energy).

*Figure 1.1: Daniel Bernoulli.*



The conclusion of the work that defined the Bernoulli principle says that the sum of all energy in the fluid flow—both kinetic energy and potential energy—remains constant regardless of conditions.

Mathematically in the simplest terms, this is expressed in the pressure version of Bernoulli's equation:

$$P + \frac{\rho v^2}{2g_c} = H$$

Where:

$P$	Fluid pressure (i.e., potential energy)
$\frac{\rho v^2}{2g_c}$	Dynamic pressure (i.e., kinetic energy)
$\rho$	Fluid density
$v$	Fluid velocity
$g_c$	Inertial force conversion constant
$H$	Total pressure

While this relationship holds for many types of flowing fluid applications, it is an approximation because it applies to an ideal fluid. Real fluids have viscosity, which creates local losses of energy that are not accounted for in the Bernoulli equation. Despite this limitation, the modern DP flow meter uses the Bernoulli equation to determine the flow rate with corrections applied for the real nature of fluids. See [Chapter 3](#) for more information on Bernoulli's equation.

Other concepts have been developed from Bernoulli's work. For example, flow over an airfoil and the mechanism of lift harnesses Bernoulli's principle in aircraft. Flow through a restriction, while named for another researcher, Giovanni Battista Venturi (1746-1822), shows Bernoulli's principle in one of the first DP flow meters, called the Venturi tube. One common use of the Venturi tube is in carbureted internal combustion engines, where the pressure drop across the Venturi tube pulls gasoline into the air stream entering the engine.

## 1.2.2 The Reynolds Number

Osborne Reynolds (1842-1912) is a second key scientist who contributed significantly to the theory behind the flow of fluids in pipes. Reynolds was a student of mechanics who became interested in fluid dynamics and was appointed the professor of engineering at Owens College in Manchester, England. His work began with the practical steam fitting of ships, but he then pursued a vast array of studies, among them the mechanism for the drag of ships in water, the condensation of steam, the kinetic theory of gases, propeller design, turbine propulsion design, and hydraulic brakes.

Figure 1.2: Osborne Reynolds.<sup>1</sup>



Most famously, he studied the flow of fluids in pipes and the conditions under which the character of the moving fluid transitions from laminar to turbulent flow. Out of this study, the dimensionless Reynolds number,  $Re$ , was created. The Reynolds number quantifies the relationship of inertial forces to viscous forces, or:

$$Re = \frac{\text{Inertial Force}}{\text{Viscous Force}}$$

The Reynolds number characterizes a flowing fluid application and allows the study of large structures in a moving fluid to be modeled on a much smaller scale. This technique is used today in the study of ship and airplane designs before the full-size version is constructed.

<sup>1</sup>Cropped photo of a painting of Osborne Reynolds painted by John Collier in 1904.

Since the Reynolds number describes the flowing characteristics of a fluid, it is central to the design and operation of DP flow meters. The characteristics of fluid flow in a pipe, as Reynolds found, are in three ranges, or regimes, of Reynolds number values:

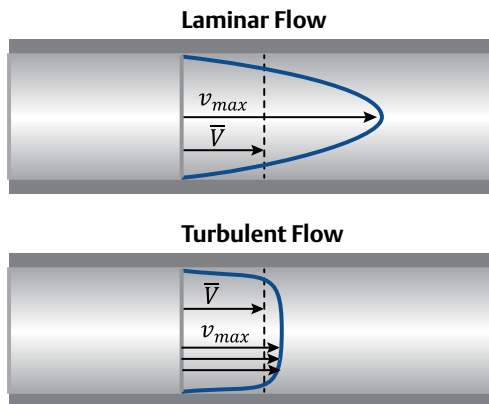
1. Laminar flow —  $0 < Re < 2300$
2. Transition flow —  $2300 \leq Re < 4000$
3. Turbulent flow —  $Re \geq 4000$

These ranges are approximate values as the transition from laminar to turbulent is dependent on the condition of the pipe wall. The point of change is called the critical Reynolds number, and it will be different for different types of pipes. [Figure 1.3](#) shows the velocity profile in a pipe for the two types of flow.

Where:

- $\bar{v}$  Average velocity in the pipe
- $v_{max}$  Maximum velocity in the pipe which is at the pipe center for undisturbed flows

**Figure 1.3: Pipe flow characteristic types.**



If the Reynolds number is used to characterize industrial pipe flow, a range of Reynolds numbers is produced for each pipe and reveals the application range that any industrial flow meter must be able to operate in. The fluids and velocities that flow in the majority of industrial

pipings are in the turbulent range and are far above the critical Reynolds number. This makes the job of applying flow meters much simpler as there is only one type of characteristic flow that must be accommodated.

## 1.3 Differential Pressure and the DP Flow Meter

The DP flow meter provides the ability to calculate the flow rate by measuring the difference in pressure between two taps on the primary element or the pipe in which it is installed. How is this done? Pressure is a force that is exerted over an area by a fluid. This force can be measured simply and remotely using small tubing connected to the measuring instrument. Most pressure gauges are actually differential pressure gauges in that they measure the difference between a pipe or vessel pressure and the atmospheric pressure. The first pressure gauge was a manometer, which is a vertical glass tube that allows liquid to rise until the pressure is balanced against the weight of the liquid. A manometer uses a U-shaped tube, or two vertical tubes connected at the bottom, with a liquid filling the tubes partway. When the two pressures are applied at the top of each tube, the liquid in the two tubes change height, and a scale fixed to the manometer is used to measure the height difference,  $h$ . The measurement of the fluid height is an indication of pressure. For the earliest DP flow meters, both tubes of a U-tube style manometer are connected to the taps of the DP flow meter primary element. The indication for this type of manometer is the differential pressure.

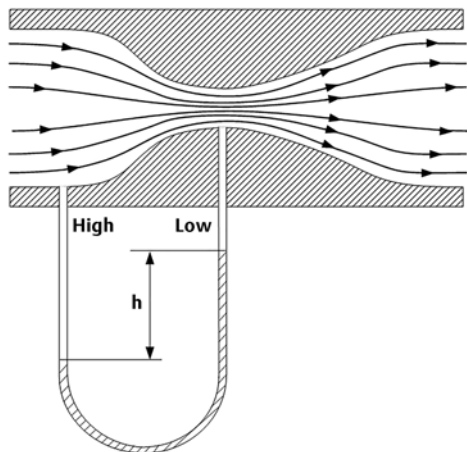
[Figure 1.4](#) shows a Venturi tube and a simple manometer that is reading the DP as a height of liquid column,  $h$ . The value of this difference in pressure between the high and low taps is:

$$DP = \Delta P = h \frac{g_i}{g_c} (\rho_m - \rho_f)$$

Where:

$\Delta P$	Differential pressure
$h$	Height of the liquid column
$g_i$	Local acceleration of gravity
$\rho_m$	Density of the manometer fluid
$\rho_f$	Density of the flowing fluid

**Figure 1.4:** A DP flow meter using a U-tube manometer to measure the differential pressure.



Although manometers are now rarely used to read DP for a flow meter, the unit inches of water column, or inH<sub>2</sub>O (mmH<sub>2</sub>O), is still associated with DP flow measurement. See Chapter 2 for more information on differential pressure and the manometer.

## 1.4 DP Flow Basics

### 1.4.1 What is Flow?

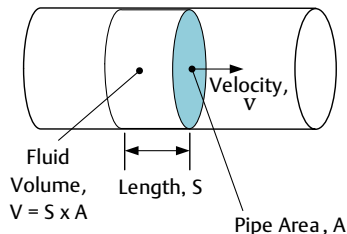
Flow is the measure of fluids in motion, specifically in some type of conduit. A fluid can be either a liquid or a gas. Open-channel flow is liquid flow in a canal, ditch, or riverbed. Closed channel flow is flow in an enclosed pipe, duct, or culvert. The DP flow meter can measure most any type of fluid flow; however, the following are general application requirements:

1. Flow should completely fill the enclosed pipe; a partially full pipe will lead to an inaccurate measurement.
2. The density must be known or determined based on the fluid properties, such as that for a gas with changing pressure and temperature. If the density changes, the calculated flow should take the density change into account or the flow reading will be in error. However, since the density factor is under the square root in the DP flow equation, the effect on the accuracy of the flow rate is one half the change in density.
3. The viscosity should be known and constant for given values, either assumed or measured, of pressure and temperature. Fluids where viscosity changes based on the flow rate, which are called non-Newtonian fluids, are difficult to measure with DP flow meters. For these applications, a different flow technology should be considered.
4. The flow needs to be at equilibrium, or what is called steady state. DP flow metering is based on a balance in energy for a system where there are no time-dependent components.

### 1.4.2 Principles of Flow Metering

Volumetric flow rate equals the volume of fluid passing through a particular cross section of a pipe over a specific time period. An example is shown in [Figure 1.5](#).

**Figure 1.5:** Fluid flow in a pipe.



Since many flow meter operating equations use the fluid velocity to determine the flow rate, it is important to review the relationships between these parameters.

$$Q_v = \frac{V}{t}$$

Where:

$Q_v$  Volumetric flow rate

$V$  Unit of volume

$t$  Time

The volume of fluid being considered is the cross-sectional area of the pipe multiplied by the length of the section of the fluid that passed over the point for the specific time period.

$$V = A \times s$$

Where:

$V$  Unit of Volume

$A$  Area

$s$  Length

Since velocity,  $v$ , is distance traveled divided by time, the velocity a cross-section of fluid travels over a specific unit of time is calculated as:

$$v = \frac{s}{t}$$

This yields the simplest equation for flow rate, which is:

$$Q_v = A \times v$$

Because:

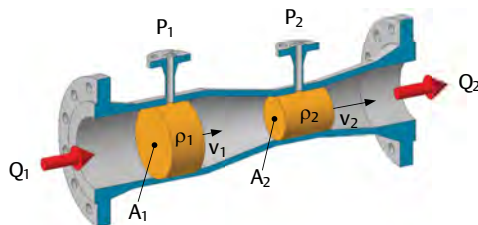
$$Q_v = \frac{V}{t} = \frac{A \times s}{t} = A \times \frac{s}{t} = A \times v$$

In other words, volumetric flow rate is equal to the velocity of the fluid times the cross-sectional area of the pipe. For the mass flow rate, the volumetric flow is converted to mass flow by multiplying by the fluid density:

$$Q_m = Q_v \times \rho = A \times v \times \rho$$

The DP flow meter measures the velocity of the fluid. The area for a DP meter used to calculate the flow rate is the area of the constriction shown in [Figure 1.6](#) as the cross-sectional area labeled  $A_2$ .

**Figure 1.6: The area meter and conservation of mass.**



A primary element that uses a constriction in the pipe to produce a DP is called an area flow meter. [Figure 1.6](#) shows an area flow meter with pressure taps at the inlet and throat sections. Using Bernoulli's energy equation:

$$\frac{P_1}{\rho_1} + \frac{v_1^2}{2g_c} = \frac{P_2}{\rho_2} + \frac{v_2^2}{2g_c}$$

This states that the total energy at the meter inlet (1) must equal the total energy at the meter throat (2).

There is another principle of fluid mechanics that is needed here, and it is called the continuity equation. This equation states that what flows into a pipe must come out of the pipe, and the flow rate is constant at any section of the pipe. Another way to state this is that mass flow is conserved, or:

$$\dot{Q}_{m1} = \dot{Q}_{m2}$$

Note that in [Figure 1.6](#), the area of the pipe decreases from  $A_1$  to  $A_2$ . Using the equation above for mass flow gives:

$$A_1 \times v_1 \times \rho_1 = A_2 \times v_2 \times \rho_2$$

The decrease in area causes a corresponding increase in velocity. This equation is used to complete the area DP flow meter equation, which combines Bernoulli's equation and the continuity equation to solve for the flow rate. See [Chapter 3](#) for a complete derivation.

## 1.4.3 The Pitot Tube

A direct way to measure the fluid velocity is by using a pitot tube. A pitot tube measures the pressure due to the fluid coming to rest on a fixed point in a flow stream, which is the same thing experienced when putting a flattened hand out of the car window while on the highway.

This pressure is called the stagnation pressure and is related to the velocity by:

$$P_o = \frac{\rho v^2}{2g_c}$$

Where:

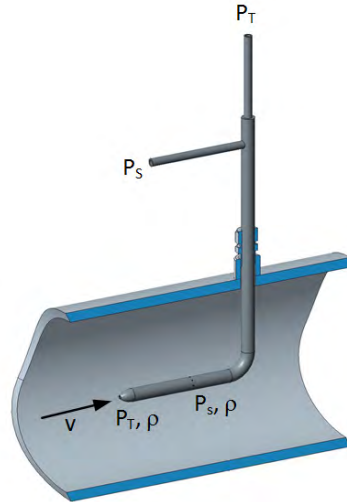
$P_o$  Stagnation pressure, which is the differential pressure across the pitot tube, ( $P_T - P_S$ )

$P_T$  Total pressure (also called  $H$ )

$P_S$  Static pressure

Figure 1.7 shows a standard research-style pitot tube installed in a pipe. The fluid velocity in front of the pitot tip,  $V$ , is determined by measuring the differential pressure and knowing the fluid density. In this case, velocity cannot be seen, so differential pressure, which can be seen, is measured in order to determine the velocity. The total pressure is sensed at the pitot tip and the static pressure from holes drilled through the surface of the pitot cylinder at right angles to the flow. This was one of the first methods used for calculating the fluid velocity in a closed conduit. However, the pitot tube does not make a good industrial flow meter. It measures only a single point unless it is moved across the pipe diameter and the velocity sampled. It is also not structurally strong enough for liquid service in larger pipes. For this reason, the averaging pitot tube was developed. More information on this technology is available in [Chapters 7](#) and [9](#).

Figure 1.7: A pitot tube installed in a pipe.



## 1.4.4 The DP Flow Meter

All DP primary elements will generate a differential pressure. This difference in pressure, or DP, is proportional to the flow rate in the pipe. Expressed mathematically:

$$Q = K_c \times \sqrt{\Delta P}$$

Where:

$Q$  Flow rate

$K_c$  Proportionality constant

$\Delta P$  Measured differential pressure

$K_c$  is calculated based on primary element geometry, the primary element design, and the operating conditions of the fluid being measured. This is the fundamental relationship that governs DP flow technology.

Differential pressure is the most common type of flow meter technology used today. There are two important elements needed to create a DP flow meter as shown in [Figure 1.8](#):

1. The primary element is a device that is installed in the pipe to create a differential pressure, and it incorporates taps for measurement of this DP.
2. The secondary element, which is a DP indicator or meter, measures the pressure difference and can provide an output proportional to the flow rate by taking the square root of the measured DP. The secondary element can also be a multivariable transmitter, which measures not only DP but also the static pressure and temperature of the fluid in the pipe. These measurements are then used by the multivariable transmitter electronics to calculate a precise value of flow rate.

A third component may also be required depending on the configuration of the first two elements. When the flow rate is not provided by the transmitter, a calculation must be done in order to derive flow from differential pressure measurement. This is typically done in one of two ways: the DP measurement can be sent to a flow computer, which does the flow calculation based on application parameters and other measurements, or the flow calculation can be done in the distributed control system (DCS). Both of these techniques require additional equipment, installation, and engineering work.

**Figure 1.8:** A typical DP flow meter. The primary element can be an orifice plate or an averaging pitot tube.



DP flow technology works best with clean, homogeneous fluids, although some primary elements can be used with dirty or solid-laden fluids. Some important guidelines for applying DP flow meter technology are:

1. Select the proper primary element to meet the requirements of the application.
2. Install and commission the flow meter correctly.
3. Perform the required maintenance to ensure that the primary element is unobstructed and has not been worn down.
4. Verify that the DP transmitter is operating within the performance specifications.

See [Chapter 10](#) for more information.

## 1.4.5 The Primary Element

There are several types of DP primary elements:

- Orifice plates and multi-hole orifice plates
- Averaging pitot tubes
- Venturi tubes
- Wedge meters
- Cone meters
- Flow nozzles

Each of these primary elements operates on the same principle that creating a change in pressure is proportional to the flow rate. See [Chapter 7](#) for more information on these primary elements. The advantage of having several types to pick from is that there is a primary element for nearly every application. The challenge is to understand the application so that the appropriate primary element can be selected.

## 1.4.6 The Secondary Element

The secondary element reads the differential pressure generated by the DP flow primary element. There are simple DP meter indicators that read the signal mechanically on a scale,



but the most common and the meter of choice for industrial flow metering is the DP transmitter. DP transmitters are designed to convert the mechanical pressure signal into an analog or digital signal and convey it to the control system or panel. They are designed and manufactured to provide accurate measurement over wide operating ranges. [Figure 1.9](#) shows a simple DP transmitter. If it is desired to have an output proportional to flow, the square root of the differential pressure measurement can be calculated by the transmitter. Otherwise, this calculation of the square root should be done someplace else, typically in the control system. Care must be taken to avoid taking the square root in both places, as this will result in large errors. A multivariable transmitter is a DP transmitter that is capable of measuring additional process variables, including static pressure and temperature. When used as a mass flow transmitter, these measurements help to compensate for changes in density, fluid conditions, and other flow parameters.

**Figure 1.9:** A typical DP transmitter.



Although a multivariable transmitter is initially more expensive than a traditional DP transmitter, savings are realized by not having separate device installations. This means fewer transmitters, less wiring, fewer process penetrations, and lower overall installed cost. Since a flow computer or separate calculations are no longer required, engineering time and DCS processor load are reduced, and response time is increased. Multivariable transmitters, unlike traditional differential pressure transmitters, are also capable of providing mass flow, energy flow, volumetric

flow, and even totaled flow for data logging purposes. See [Chapter 8](#) for more information on DP and multivariable transmitters.

## 1.5 DP Flow Measurement Applications

DP flow measurement optimizes many different aspects of a process including:

- Flow monitoring and balancing — Monitoring the fluid flow rates within a system at strategic locations to ensure operation and balanced systems.
- Production efficiency — The measurement of flow rate is part of a broad range of process control variables related to efficiency, from batch control to byproduct scavenging to emissions monitoring.
- Process control — Processes for the chemical, refining, and manufacturing industries often include multiple fluid flow measurements. Control over the flow of critical fluids is key to quality production.
- Safety — Monitoring the flow rate for utilities and production fluids allows the establishment of safe ranges of flow and can be integrated into an alarm system if these ranges are exceeded.
- Internal billing/allocation — Tighter control over inventories and process rates contributes directly to profitability. For many producers, internal billing around fluid-related process costs directly impacts the bottom line.
- Custody transfer — Flow metering is the cash register for fluid products sold by volume or weight. An accurate measurement on the dispensing side accounts for every drop, and on the receiving side, minimizes overcharging.

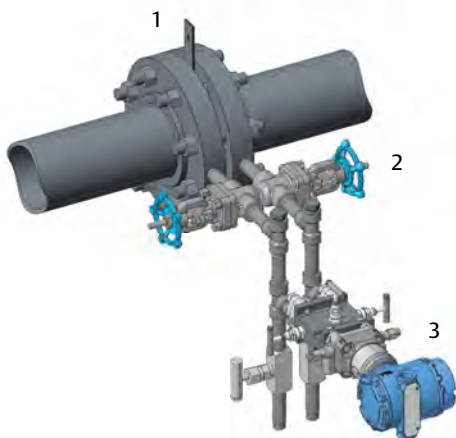
## 1.6 DP Flow Meter Installations: Traditional vs. Integrated

In general, process instrumentation has seen a great deal of form and integration over the last two decades. DP flow is no exception. Currently there are two broad types of DP flow meters available: traditional and integrated.

### 1.6.1 Traditional DP Flow Meter

The traditional DP flow meter installation requires a minimum of three separate components. *Figure 1.10* shows a typical orifice plate system including the primary element, impulse piping, and DP transmitter.

*Figure 1.10: The traditional DP flow installation method.*



1. Orifice Plate (Primary Element)
2. Connection Hardware (Impulse Lines, Tubing, Fittings, Valves, etc.)
3. DP Transmitter (Secondary Element)

The traditional installation method requires component-by-component engineering to meet the requirements of the installation. Parts may be procured separately and assembled on-site. When properly engineered and installed, this configuration provides good performance and can meet custody transfer standards.

Due to its long history, many traditions and accepted standards around DP flow measurement have emerged. Some of these traditions, however, have led to outdated or erroneous methods of engineering DP flow, resulting in sub-optimized technology and inherent limitations and problems. These include multiple potential leak points at joints, separate valves and manifolds, and potential accuracy problems due to long impulse lines. In addition, the installation is time-consuming with many components, and it requires careful configuration to ensure proper operation.

### 1.6.2 Integrated DP Flow Meter

*Figure 1.11* shows an integrated flow meter, which combines the primary element and the DP transmitter into a single device. All of the required elements for the flow meter are included. It was developed in large part to minimize the challenges around installation of the traditional DP flow meter, such as assembly of impulse piping on-site. The system is leak tested to ensure integrity, and it is fully configured and preassembled prior to being shipped in order to make the installation easier. When used with a multivariable flow transmitter, fluid pressure and temperature can be read without any additional pipe penetrations or instruments.

*Figure 1.11: The integrated DP flow meter combines both the primary element and the transmitter into a single unit, thereby reducing potential leak points during installation and use.*



## 1.6.3 A Comparison — Traditional Versus Integrated DP Flow Meters

Figure 1.12 compares a traditional DP flow meter with pressure and temperature measurement and flow computer with an equivalent fully integrated DP flow meter. Each individual component that makes up the meter system is identified in both systems.

The benefits of using an integrated DP flow meter are:

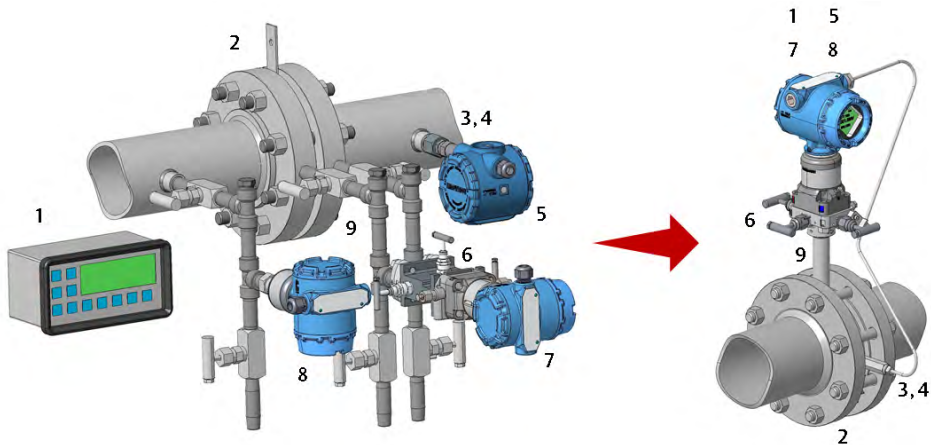
- Fewer potential leak points (leak checked at the factory)
- Reduced long-term maintenance issues
- Decreased susceptibility to freezing and plugging
- More compact footprint
- Simplified ordering and installation

Emerson’s Rosemount™ integrated flow meters combine industry-leading transmitters with innovative primary element technologies and connection systems. There are effectively 10 devices in one flow meter, thereby simplifying engineering, procurement, and installation.

## 1.7 Alternative Flow Technologies

There are other methods used to measure the flow of fluids in an enclosed pipe. The four most popular alternative technologies (i.e., Coriolis, magnetic, vortex, and ultrasonic) will be described here, although there are other types including open channel, optical, thermal mass, turbine, paddle wheel, and positive displacement.

Figure 1.12: Traditional and integrated DP flow metering system compensated for temperature and pressure.



1. Flow Computer
2. Primary Element
3. Thermowell
4. Temperature Sensor
5. Temperature Transmitter

6. DP Manifold
7. DP Transmitter
8. Pressure Transmitter
9. Connection Hardware

## 1.7.1 Coriolis

The operation of a Coriolis flow meter is based on the mechanics of motion. The Coriolis force happens when a mass moves in a rotating inertial frame. The rotation is created by vibrating two opposing tubes on the flow meter. When a fluid flows through the opposed vibrating tubes, the tubes twist due to the Coriolis force. The twisting alternates with the vibration and creates two phase-shifted sinusoidal waveforms on coils mounted to the tubes. The amount of shift is proportional to the mass flow rate. In addition, the frequency of vibration is proportional to the fluid density. The signal shift and the frequency of vibration can be precisely measured, which makes the Coriolis meter one of the most accurate types of flow meters.

## 1.7.2 Magnetic

Magnetic flow meters operate on Faraday's Law of Electromagnetic Induction. Electrodes mounted on opposite sides of the flow meter body measure a voltage generated by the flow of a conductive liquid in a magnetic field. The voltage generated is proportional to the flow rate. The magnetic flow meter uses a full-sized pipe spool that is lined with one of several types of inert plastic materials. This makes the magnetic flow meter ideal for use in applications with dirty fluids, sewage, or slurries.

## 1.7.3 Vortex

Vortex flow meters utilize a bluff body or cylinder mounted in a pipe spool that creates alternating vortices behind the cylinder. The frequency of the alternating vortex is proportional to the fluid velocity. Vortex flow meters have no moving parts to maintain or repair, and the signal is read electronically and simply converted to a flow rate. Vortex meters work well with most clean fluids and have similar application ranges to DP flow meters.

## 1.7.4 Ultrasonic

Ultrasonic flow meters calculate the flow rate by utilizing the speed of sound through a fluid created by transducers mounted to the pipe wall. There are two types of ultrasonic meters: Doppler and Time-of-Flight. The Doppler ultrasonic meter requires particles in the fluid to reflect sound waves back to the pipe wall transducers. The difference in frequency between the sent and reflected wave is proportional to fluid velocity. The Time-of-Flight ultrasonic meter requires a clean fluid and works by using opposing transducers mounted to transmit/receive sound waves at an angle across the pipe. The difference in the time required to send a pulse along the path between transducers in the direction of flow vs. against the flow is proportional to the fluid velocity. Some models use multiple pairs of transducers to fully cover the pipe cross-section, which provides a more accurate flow rate than a single-path meter.

Each of the flow measurement systems described here uses advanced technology to measure the flow rate, and each has application strengths and weaknesses. However, the DP flow meter system used for industrial flow meter applications remains the most common flow measurement technology due to its long history, ease of use, reliability, and wide application range.



# 2

## Fluids and Flow Basic Terms and Concepts

	<b>Topic</b>	<b>Page</b>
2.1	Introduction	14
2.2	Physical Fluid Properties	14
2.3	Fluid Flow Basics	34
2.4	DP Flow Basic Terms	35
2.5	Applicable Flow Meter Standards	38

### 2.1 Introduction

This chapter presents a background in the primary properties that describe the behavior of fluids needed to determine the flow rate. There is also a brief introduction to fluid flow terms related to the differential pressure (DP) flow meter.

There are many types of fluids. The flow of most fluids used in industry can be measured using DP flow meters. Some have properties that make measurement difficult. All fluids can be characterized by several properties that define the behavior of the fluid under flowing conditions.

### 2.2 Physical Fluid Properties

A fluid is a substance that continues to deform when subjected to a shear stress while at rest. See [Figure 2.1](#). Fluids can be liquids, vapors, or gases. For most fluids, some of the fluid properties can be calculated by knowing other properties. The density and viscosity of fluids are used to predict the effects a fluid has on a DP flow meter. Gases are considered ideal or real based on the change in gas density as the pressure and temperature change. A review of the difference between the values of the ideal and real gas calculations will be presented.

**Figure 2.1: A fluid at rest deforms under shear stress.**



In DP flow, there are two key parameters that must be known to properly size and use a DP flow meter: density and viscosity. Fortunately for the most common fluids, the two parameters can be determined simply by knowing the fluid. Since both fluid properties vary with pressure and temperature, the normal operating pressure or temperature range for the flow meter application needs to be known.

In addition to the density and viscosity, the isentropic ratio, or the ratio of specific heats,  $c_p/c_v$ , is used to predict the effects of the compressibility of a gas on the DP flow meter signal. This value is also dependent on the gas conditions.

#### 2.2.1 Mass, Force, and Weight

When working with fluids in motion, it is important to understand the physics behind the concept of mass, force, and weight. Fluids exert forces when changing direction or when the flow goes through or around objects. The relationship between mass, force, and weight is needed to understand these physical quantities and how they are used in the DP flow meter equation.

The conversion of mass in motion to force is derived using Newton's second law of motion (see [Figure 2.2](#)), which has the following form:

$$F = ma$$

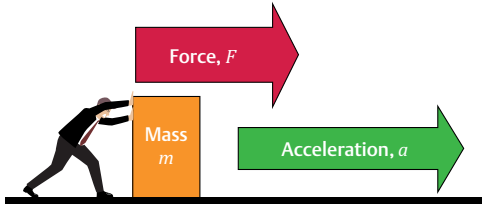
Where:

$F$  Force applied to or by an object,  $lb_f(N)$

$m$  Mass of the object,  $lb_m(kg)$

$a$  Resulting acceleration of the object,  
 $\frac{ft}{sec^2} \left( \frac{m}{sec^2} \right)$

**Figure 2.2: Newton's law of force, mass, and acceleration.**



The term on the right side of the equation,  $ma$ , is called the inertial force. To equate this term to the body force,  $F$ , requires that the units be the same. To do this, a conversion called the inertial force conversion constant,  $g_c$ , is used. The actual Newton's second law equation is then:

$$F = \frac{ma}{g_c}$$

Where:

$$g_c = \begin{array}{l} \text{Inertial force conversion constant,} \\ 32.174 \text{ lb}_m \cdot \text{ft}/(\text{lb}_f \cdot \text{sec}^2) \\ (1 \text{ kg} \cdot \text{m}/(\text{N} \cdot \text{sec}^2)) \end{array}$$

In U.S. Customary (USC) units, weigh scales were initially calibrated in pounds with no concern for force or mass, so a value of  $1 \text{ lb}_m = 1 \text{ lb}_f$ , but only on the surface of the earth at  $45^\circ$  latitude.

Weight is the force that an object exerts on the earth's surface due to gravity. Weight can be defined by substituting the acceleration of gravity,  $g$ , for  $a$ :

$$W = m \frac{g}{g_c}$$

Where:

$$W \quad \text{Weight, lb}_f(\text{N})$$

$$g \quad \text{Local acceleration of gravity, which changes from } 32.088 \text{ ft/sec}^2 \text{ (9.781 m/sec}^2\text{) at the equator to } 32.259 \text{ ft/sec}^2 \text{ (9.833 m/sec}^2\text{) at the poles to } 32.174 \text{ ft/sec}^2 \text{ (9.807 m/sec}^2\text{) at } 45^\circ \text{ latitude (i.e., standard gravity)}$$

Using Newton's second law equation without any friction,  $1 \text{ lb}_f$  will accelerate  $1 \text{ lb}_m$  at a rate of  $32.174 \text{ ft/sec}^2$ , and  $1 \text{ N}$  will accelerate  $1 \text{ kg}$  at a rate of  $1 \text{ m/sec}^2$ , or:

$$1 \text{ lb}_f = \text{lb}_m \times 32.174 \frac{\text{ft}}{\text{sec}^2} / (32.174 \text{ lb}_m \cdot \frac{\text{ft}}{\text{lb}_f \cdot \text{sec}^2})$$

for USC units, and

$$1 \text{ N} = 1 \text{ kg} \times 1 \frac{\text{m}}{\text{sec}^2} / (1 \text{ kg} \cdot \frac{\text{m}}{\text{N} \cdot \text{sec}^2})$$

for SI units

Notice that when using the value  $g_c$ , the units on the right side of the equation are in force. For SI units, the value of  $g_c$  is 1, because a newton was defined to be exactly equal to  $1 \text{ kg} \times 1 \text{ m/sec}^2$ .

This term is sometimes left out in SI unit equations where it should be shown. The use of  $g_c$  is necessary in flow measurement when equating force and inertia in the DP flow equations.

This concept is also used in fluid statics when converting gravitational head to pressure, as is done with a manometer.

### 2.2.2 Density

The density of a fluid is the mass of a fluid per unit volume, or

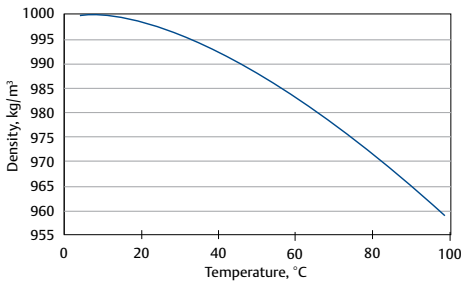
$$\rho \text{ (density)} = \text{mass}/(\text{unit volume})$$

Note that for the same mass, the volume occupied by that mass will change with temperature and pressure. Density is an intensive property, meaning that it is the same no matter how much fluid there is. The effects of temperature and pressure on the density of liquids and gases are shown in [Table 2.1](#). Liquids are typically considered incompressible because their change in density with a change in pressure is very small and is considered negligible for pressures seen in common industrial flow metering. For this reason, the density of common liquids is usually given by temperature only. [Figure 2.3](#) shows the density of water in  $\text{kg/m}^3$  over a temperature range of 32 to 212 °F (0 to 100 °C).

**Table 2.1: The values of density and viscosity depend on the temperature and pressure of the fluid.**

Liquids
↑ Temperature - ↓ Density ↓ Temperature - ↑ Density
↑ Pressure - Negligible Change ↓ Pressure - Negligible Change
↑ Temperature - ↓ Viscosity ↓ Temperature - ↑ Viscosity
Gases
↑ Temperature - ↓ Density ↓ Temperature - ↑ Density
↑ Pressure - ↑ Density ↓ Pressure - ↓ Density
↑ Temperature - ↑ Viscosity ↓ Temperature - ↓ Viscosity

**Figure 2.3: Density of water by temperature.**



The density of a gas will change with a change in pressure or temperature because gases are compressible. For this reason, knowing the density of a gas requires the temperature and pressure as well as the gas molecular weight and is calculated using equation of state. See [Section 2.2.7.2](#).

### 2.2.3 Specific Weight and Specific Gravity

Specific weight is the weight due to gravitational pull of a pure or homogeneous substance per unit volume. Common units for specific weight are  $\text{lb}_f/\text{ft}^3$  ( $\text{N}/\text{m}^3$ ). Using the formula for weight above, the weight per unit volume can be equated to the mass per unit volume by:

$$\frac{W}{V} = \frac{m}{V} \times \frac{g_i}{g_c}$$

Where:

$$\frac{w}{v} \quad \text{Specific weight, } \gamma, \frac{\text{lb}_f}{\text{ft}^3} \left( \frac{\text{N}}{\text{m}^3} \right)$$

$$\frac{m}{v} \quad \text{Density, } \rho, \frac{\text{lb}_m}{\text{ft}^3} \left( \frac{\text{kg}}{\text{m}^3} \right)$$

Using the symbols for specific weight and density:

$$\gamma = \rho \times \frac{g_i}{g_c}$$

The numerical value for specific weight of a fluid equals the density of that fluid at standard gravity ( $45^\circ$  latitude). However, if a substance with equal density and specific weight on earth were taken completely away from the gravitational pull, the density would remain the same, but the specific weight would be zero. Specific weight is often used in hydraulic applications, where water or another liquid is being moved in systems that include open tanks or reservoirs. Vertical height of a fluid or potential energy plays a major role in these systems.

Specific gravity,  $G$ , for a liquid is the ratio of the density of one substance to the density of a reference substance. For liquids, the reference substance is water at maximum density, which occurs at a temperature of  $39.2^\circ\text{F}$  ( $4^\circ\text{C}$ ) and atmospheric pressure,  $14.6959$  psi ( $101.325$  kPa), and the specific gravity is given by:

$$G_f = \frac{\rho_f}{\rho_{ref}}$$

Where:

$G_f$  Specific gravity at the flowing condition (specified by the subscript  $f$ )

$\rho_f$  Fluid density at the flowing condition

$\rho_{ref}$  Density of the reference substance at reference conditions of water at  $39.2^\circ\text{F}$  ( $4^\circ\text{C}$ ),  $62.464$   $\frac{\text{lb}_m}{\text{ft}^3}$  ( $999.97$   $\frac{\text{kg}}{\text{m}^3}$ )



## 2 – Fluids and Flow Basic Terms and Concepts

Specific gravity as a unit was popular in pre-digital times when hand calculations were done. Specific gravity normalizes the value of density. For water at reference conditions it is one, and at higher temperatures, it is less than one. Other liquids are then referenced to water, and the value of specific gravity indicates whether the liquid is lighter or heavier than water. [Table 2.2](#) shows the density and specific gravity of a selection of common liquids.

The reference fluid for specific gravity of gases is air. Specific gravity of a gas is defined as the ratio of the molecular weight of the gas,  $M$ , to

the molecular weight of air,  $M_{air}$ , (defined as 28.96247 g/g mole):  $G = M/M_{air}$ . This method also normalizes the specific gravity using air as a reference. Gases that have a specific gravity less than one are lighter than air and vice versa. [Table 2.3](#) lists the specific gravity for some common gases.

### 2.2.4 Liquid Mixtures

When a liquid is made up of two or more pure liquids, the density of the mixture can be found if each component density and their total volume or mass is known.

**Table 2.2: Liquid specific gravity. Liquids lighter than water are in gray, and liquids heavier than water are in blue.**

Liquid	Temperature		Specific Gravity, G	Liquid	Temperature		Specific Gravity, G
	°F	°C			°F	°C	
Acetylene, Liquid	69.8	21.0	0.380	Crude Oil, California	60.1	15.6	0.918
Methane, Liquid	-263.2	-164.0	0.466	Coconut Oil	59.0	15.0	0.927
Propane	77.0	25.0	0.495	Cotton Seed Oil	59.0	15.0	0.929
Propylene	77.0	25.0	0.516	Linseed Oil	77.0	25.0	0.932
Ethane	-128.2	-89.0	0.572	Carbolic Acid	59.0	15.0	0.959
Butane, Liquid	77.0	25.0	0.601	Castor Oil	77.0	25.0	0.959
Hexane	77.0	25.0	0.657	Crude Oil, Mexico	60.1	15.6	0.976
Naptha	59.0	15.0	0.667	Water, Pure	39.2	4.0	1.000
Heptane	77.0	25.0	0.681	Water, Sea	77.0	25.0	1.028
Octane	77.0	25.0	0.701	Milk	77.0	25.0	1.035
Olive Oil	59.0	15.0	0.703	Propylene Glycol	77.0	25.0	1.036
Gasoline	60.1	15.6	0.713	Acetic Acid	77.0	25.0	1.052
Ether	77.0	25.0	0.716	Creosote	59.0	15.0	1.070
Pentane	77.0	25.0	0.755	Phenol	77.0	25.0	1.075
Acetone	77.0	25.0	0.787	Ethylene	77.0	25.0	1.100
Alcohol, Ethyl	77.0	25.0	0.787	Glycerol	77.0	25.0	1.129
Alcohol, Methyl	77.0	25.0	0.791	Oxygen, Liquid	-297.4	-183.0	1.140
Hydrazine	77.0	25.0	0.797	Refrigerant R-22	77.0	25.0	1.197
Alcohol, Propyl	77.0	25.0	0.802	Glycerin	77.0	25.0	1.263
Formaldehyde	113.0	45.0	0.815	Carbon Disulfide	77.0	25.0	1.265
Kerosene	60.1	15.6	0.820	Flourine Refrigerant R-12	77.0	25.0	1.315
Ammonia, Aqueous	77.0	25.0	0.826	Phosgene	32.0	0.0	1.381
Toluene	77.0	25.0	0.865	Chloroform	77.0	25.0	1.469
Turpentine	77.0	25.0	0.871	Refrigerant R-11	77.0	25.0	1.480
Benzene	77.0	25.0	0.876	Carbon Tetrachloride	77.0	25.0	1.589
Crude Oil, Texas	60.1	15.6	0.876	Bromine	77.0	25.0	3.120
Fuel Oil	60.1	15.6	0.893	Mercury	77.0	25.0	13.633
Styrene	77.0	25.0	0.906				

## 2 – Fluids and Flow Basic Terms and Concepts

Table 2.3: Gas specific gravity for some common gases. Gases lighter than air are in gray, and gases heavier than air are in blue.

Gas	Specific Gravity, G	Gas	Specific Gravity, G
Hydrogen, H <sub>2</sub>	0.070	Hydrochloric Acid, HCl	1.261
Helium, He	0.138	Hydrogen Chloride, HCl	1.268
Illuminating Gas	0.400	Flourine, F <sub>2</sub>	1.310
Coke Oven Gas	0.440	Argon, Ar	1.380
Methane, CH <sub>4</sub>	0.554	Phosgene, COCl <sub>2</sub>	1.390
Ammonia, NH <sub>3</sub>	0.590	Propylene, C <sub>3</sub> H <sub>6</sub>	1.452
Water Vapor, H <sub>2</sub> O	0.622	Carbon Dioxide, CO <sub>2</sub>	1.519
Carbureted Water Gas	0.630	Propane, C <sub>3</sub> H <sub>8</sub>	1.522
Natural Gas (Typical)	0.650	Nitrous Oxide, N <sub>2</sub> O	1.530
Neon, Ne	0.697	Ozone, O <sub>3</sub>	1.660
Water Gas	0.710	Isobutane, (CH <sub>3</sub> ) <sub>3</sub> CH	1.940
Acetylene, C <sub>2</sub> H <sub>2</sub>	0.900	Butane, C <sub>4</sub> H <sub>10</sub>	2.006
Carbon Monoxide	0.967	Sulfur Dioxide, SO <sub>2</sub>	2.264
Nitrogen, N <sub>2</sub>	0.972	Isopentane, (CH <sub>3</sub> ) <sub>2</sub> CHC <sub>2</sub> H <sub>5</sub>	2.480
Air	1.000	Chlorine, Cl <sub>2</sub>	2.486
Blast Furnace Gas	1.020	Pentane, C <sub>5</sub> H <sub>12</sub>	2.487
Nitric Oxide, NO	1.037	Hexane, C <sub>6</sub> H <sub>14</sub>	2.973
Ethane, C <sub>2</sub> H <sub>6</sub>	1.038	Krypton, Kr	2.890
Oxygen, O <sub>2</sub>	1.104	Xenon, Xe	4.530
Hydrogen Sulfide, H <sub>2</sub> S	1.176	Mercury Vapor, Hg	6.940

For a liquid mixture made up of components as a percent of volume, the derivation is:

Density of the mixture:

$$\rho_{mix} = m_{mix}/V$$

and for each component:

$\rho_i = m_i/v_i$  or,  $m_i = \rho_i v_i$ , so that:

$$\rho_1 v_1 + \rho_2 v_2 + \dots + \rho_i v_i = \sum m_i = m_{mix}$$

$x_i = v_i/V$  the volume fraction, so that:

$$\rho_{mix} = \frac{m_{mix}}{V} = \frac{\rho_1 v_1 + \rho_2 v_2 + \dots + \rho_i v_i}{V} = \sum x_i \rho_i$$

Where:

$\rho_i$	Density of the ith liquid component
$m_i$	Mass of the ith liquid component
$v_i$	Volume of the ith liquid component
$m_{mix}$	Total mass of the liquid mixture
$V$	Total volume of the mixture
$x_i$	Volume fraction

The density of the liquid mixture is the sum of the volume fractions times the density of each liquid component.

For a liquid mixture given in mass fractions:

$$\rho_{mix} = \frac{\sum m_i}{\sum v_i} = \frac{m}{\sum m_i/\rho_i} = \frac{m}{\sum x_{mi} m/\rho_i} = \frac{1}{\sum x_{mi}/\rho_i}$$

Where:

$x_{mi}$  Mass fraction of the ith liquid component

The density of the liquid mixture given in mass fractions is the inverse of the sum of the mass fraction divided by the density of each liquid component.

Note: Some combinations of liquid volumes do not add up exactly because the molecules together take up less space than the sum of the two volumes. This is true for water and ethanol. The ethanol molecule can fit between the water molecules, so 3% of the total volume is lost when mixing these liquids together. The mixture

equations shown here would need to be modified in that case.

### 2.2.5 Pressure

Pressure is a force acting on a surface in the normal direction (i.e., perpendicular) per unit area. See [Figure 2.4](#). Pressure is defined by:

$$P = \frac{\text{Force}}{\text{Unit Area}}$$

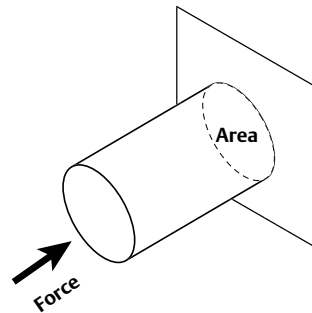
Where:

$$P \quad \text{lb}_f/\text{in}^2 \text{ or psi } \left(\frac{\text{N}}{\text{m}^2} \text{ or pascal}\right)$$

$$\text{Force} \quad \text{lb}_f \text{ (N)}$$

$$\text{Unit area} \quad \text{in}^2 \text{ (m}^2\text{)}$$

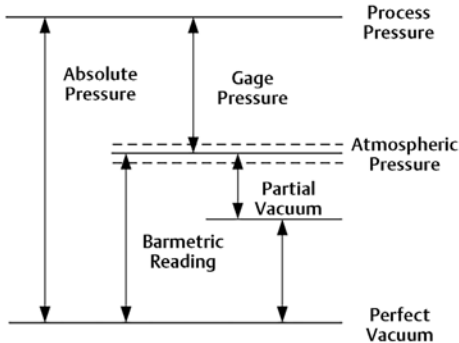
**Figure 2.4: Pressure is a force applied to an area.**



The pascal (Pa) is a very small unit of pressure and is generally expressed in kiloPascals, kPa (1000 pascals), or megaPascals, MPa (1,000,000 pascals).

[Figure 2.5](#) shows the relationship between gage, atmospheric, and absolute pressure. The pressure of the atmosphere varies with the weather. This is indicated by the dashed lines in [Figure 2.5](#). Using a mercury manometer, a standard day pressure of 29.92 inches (759.97 mm) mercury or 14.6959 psi (101.325 kPa) at sea level is assigned. It is important to note that as the altitude increases, the atmospheric pressure decreases. [Table 2.4](#) shows the atmospheric pressure on a standard day by altitude.

Figure 2.5: Gage, absolute, and atmospheric pressure.



Gage pressure measurement is the most common method to determine the pressure in a pipe and can be done with the simplest pressure gauges. It is used to monitor the process and confirms the pressure-retaining part of the flow meter will safely meet the working limits. The atmospheric pressure is added to the gage pressure to obtain the absolute pressure. Calculating the density of gases requires the absolute pressure. Using the standard day atmospheric pressure for the given altitude is typically close enough.

However, for low-pressure air flows found in boiler combustion air and similar applications, it is customary to obtain the local barometric reading to give the most accurate calculation of the air density. Another method to eliminate the effects of a changing barometric pressure is to use an absolute pressure meter or transmitter.

For flow measurement, the pipe pressure is typically measured upstream of the flow meter at a distance from  $\frac{1}{2}$  to 1 pipe diameter using a wall tap by welding a pressure fitting to the pipe and then drilling a hole through the pipe wall. The hole should have a diameter between 0.125 and 0.250 in. (3.2 to 6.4 mm). Internal burrs caused by drilling must be removed, but the hole edge should not be rounded or chamfered as errors between -0.3 to +1.1% of the dynamic pressure will occur.

Table 2.4: Barometric pressure by altitude on a standard day.

Altitude		Pressure		
(m)	(ft)	(atm)	(kPa)	(psi)
0	0	1.00	101.33	14.696
100	328	0.988	100.13	14.523
200	656	0.977	98.95	14.351
300	984	0.965	97.77	14.181
400	1312	0.953	96.61	14.012
500	1640	0.942	95.46	13.845
600	1968	0.931	94.32	13.680
700	2297	0.920	93.19	13.517
800	2625	0.909	92.08	13.355
900	2953	0.898	90.97	13.194
1000	3281	0.887	89.87	13.035
1200	3937	0.866	87.72	12.722
1400	4593	0.845	85.60	12.415
1600	5249	0.824	83.52	12.114
1800	5905	0.804	81.49	11.819
2000	6562	0.785	79.50	11.530
2500	8202	0.737	74.68	10.832
3000	9842	0.692	70.11	10.168
3500	11483	0.649	65.76	9.538
4000	13123	0.608	61.64	8.940
4500	14764	0.570	57.73	8.373
5000	16404	0.533	54.02	7.835
5500	18044	0.498	50.51	7.325
6000	19685	0.466	47.18	6.843
6500	21325	0.435	44.03	6.387
7000	22966	0.405	41.06	5.955

### 2.2.6 Temperature

Fluid temperature is a measure of molecular energy and is required for several values used in the DP flow equation. Industrial methods of measuring the temperature,  $T$ , are based on substances that change electrical resistance with temperature, such as resistance temperature

detectors (RTDs) or thermocouples that generate a voltage at the junction of dissimilar metals. There are other methods that use particle velocity, heat radiation, or kinetic energy, where the internal energy of a substance excites sensors that can read this energy level.

Measurements are typically done on the Fahrenheit or Celsius scales, which were originally devised to measure the earth's temperate range. However, most flow engineering problems require the absolute temperature scale. Absolute temperature measures the temperature above absolute zero, or above the point where all molecular motion stops.

The Celsius scale sets a temperature of 0 °C at the freezing point and 100 °C at the boiling point of pure water on a standard day. The Fahrenheit scale was developed with the freezing point of brine at 0 °F and the human body temperature (at that time) at 96 °F. The scale was later adjusted to have the freezing point of pure water at exactly 32 °F so that there are 64 divisions between freezing water and the body temperature. Later modifications to this scale set the temperature of boiling water on a standard day to 212 °F. This resulted in a human body temperature of 98.6 °F.

Converting between these two scales is often needed and is done as follows:

$$^{\circ}\text{F} = ^{\circ}\text{C} \times 1.8 + 32$$

$$^{\circ}\text{C} = (^{\circ}\text{F} - 32) / 1.8$$

The absolute scales were developed in the 19<sup>th</sup> century. British physicist William Thompson (later known as Lord Kelvin) developed the Kelvin scale and defined the value of 273.16 K (i.e., kelvins, with no degree or symbol) as the triple point of water, which is also at +0.1 °C. To allow thermodynamic computations using the Fahrenheit scale required a similar absolute scale called Rankine. The freezing point of water at

273.15 K is then 491.67 °R. The conversions for the absolute scales are:

$$^{\circ}\text{R} = \text{K} \times 1.8$$

$$\text{K} = ^{\circ}\text{R} / 1.8$$

$$\text{K} = ^{\circ}\text{C} + 273.15$$

$$^{\circ}\text{R} = ^{\circ}\text{F} + 459.67$$

The absolute temperature is used in the calculation of the gas density and other thermodynamic-based properties such as gas compressibility. When a calculation represents a change in temperature, such as thermal expansion of a solid, it is common to use °F or °C.

### 2.2.7 The Ideal and Real Gas Laws

The behavior of gases is distinct from liquids in that the separation between molecules is much greater, which allows the momentum of the moving particles to transfer energy to each other and their surroundings. The consequence is that the gas pressure inversely affects the molecule separation, and for a given amount of gas, the pressure is inversely proportional to the volume. This was discovered by Robert Boyle in 1662 and is stated as:

$$P \propto \frac{1}{V} \text{ or, } PV = a$$

Where:

*P* Pressure

*V* Volume

*a* Proportionality constant

About 100 years later, Jacques Charles, famous for his early gas balloon experiments, put forth the theory from his observations that for a given amount of gas at a consistent pressure, the volume is directly proportional to the temperature of the gas, or:

$$T \propto V \text{ or, } \frac{T}{V} = b$$

Where:

$T$  Gas temperature

$b$  Proportionality constant

The gas volume is now proportional to the temperature over the pressure:

$$V = c \frac{T}{P}$$

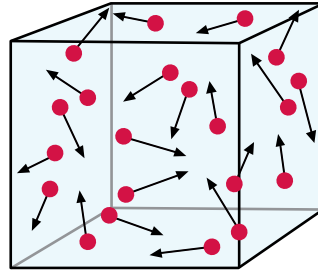
Where:

$c$  Proportionality constant

### 2.2.7.1 The Mole and Avogadro's Number

One more discovery about gases was needed before a definitive relationship between volume, pressure, temperature, and mass could be found. That discovery was made by Italian physicist Amadeo Avogadro in 1811. He found that for any gas, a given mass of that gas equal to the molecular weight of the gas will occupy the same volume at the same pressure and temperature. (Note: Molecular weight is a holdover from earlier times when weight was used to determine mass. The actual term should be molecular mass, but both descriptions are used). This discovery led to the concept of the number of molecules or atoms in a quantity of gas is the same, no matter what the gas is. The gas quantity was later called a mole. The volume occupied by 1 mole of a gas at the standard temperature and pressure (STP) of 101.325 kPa (14.696 psi) and 0 °C (32 °F) is 22.414 liters (l), which is also called the molar volume, shown in [Figure 2.6](#). The mass per mole of a gas is equal to the molecular weight and is called the molar mass of the gas in grams (g). It is important to remember that many of the common gases have molecules made up of two atoms called diatomic molecules. Hydrogen, nitrogen, fluorine, oxygen, iodine, and chlorine have molecular weights that are twice the atomic weight.

**Figure 2.6:** A mole of any gas occupies the same volume at standard temperature and pressure.



A given mass of a gas is related to the number of moles by:

$$m(g) = nM$$

Where:

$n$  Number of moles

$m(g)$  Mass of a quantity of gas, g

$M$  Molar mass, g/g-mole

The molar mass is a ratio of the mass of a gas in the given mass units equal to the molecular weight of the gas to a gas of equal volume with a molecular weight of one. This ratio does not change for different mass units, but the number of moles in a mass unit does change. In the case of a  $lb_m$ , the molar mass for air is 28.96247 g/g-mole, which means that there are 28.96247 grams in a mole of air, but the number of moles,  $n$ , in a  $lb_m$  of air is:

$$n = \frac{1 lb_m \times 453.59 g/lb_m}{28.96247 g/g - mole} = 15.66 \text{ moles}$$

The definition of a mole is in grams, so when using moles for mass units other than grams, a conversion is needed.

The volume of a mole at STP has been given as 22.414 liters. For any quantity of gas in moles, the volume is:

$$V = nV_m, \text{ or } n = \frac{V}{V_m},$$

Where:

$V_m$  Molar volume, l/mole (ft<sup>3</sup>/mole)

$V$  Volume of gas, l (ft<sup>3</sup>)

The molar volume in l/mole is converted to other volume units used in the equation. For ft<sup>3</sup>, the molar volume at STP is:

$$\begin{aligned} V_m(\text{ft}^3/\text{mole}) &= 22.414 \text{ l} \times 0.03531467 \text{ l/ft}^3 \\ &= 0.791544 \text{ ft}^3/\text{mole} \end{aligned}$$

Further studies of gases led to the discovery of the number of particles or molecules in a mole of gas. For any gas, the number of molecules in a given quantity is:

$$N_{part} = n \times N_A$$

Where:

$N_{part}$  Number of particles or molecules

$N_A$  Avogadro's number, which is  
6.02214076 x 10<sup>23</sup> molecules/mole

### 2.2.7.2 The Equation of State

The volume of any ideal gas can now be determined knowing the number of moles, the pressure, and the temperature:

$$V = nV_m c \frac{T}{P}$$

Where the value  $V_m c$  is called the universal gas constant,  $R$ . The gas volume is then:

$$V = nR \frac{T}{P}, \text{ or in the more familiar form:}$$

$$PV = nRT$$

This equation is called the equation of state. The value of the universal gas constant,  $R$ , is dependent on the units for  $P$ ,  $V$ , and  $T$  and is calculated by:

$$R = \frac{PV}{nT}$$

The calculation is done at STP as all the values are known at those conditions. For the SI units of kPa, m<sup>3</sup>, kg, and kelvins, the value for  $R$  is:

$$R = \frac{P(101.325 \text{ kPa})V(22.414 \text{ l} \times \frac{0.001 \text{ m}^3}{\text{l}})}{\left[ n(1 \text{ mole}) / \left( \frac{1000 \text{ g/kg}}{\text{g-mole}} \right) \right] T_K(273.15)}$$

$$R = 8.31441 \text{ kPa} \cdot \text{m}^3/\text{mole} \cdot \text{T}(K)$$

Noting that the pressure at STP in psi is 14.6959, and the temperature is 491.67 °R, for the USC units of psi, ft<sup>3</sup>, lb<sub>m</sub>, and Rankine, the value for  $R$  is:

$$R = \frac{P(14.6959 \text{ psi})V(0.791544 \text{ ft}^3)}{\left[ n(1 \text{ mole}) / \left( \frac{453.59 \text{ g/lb}_m}{\text{g-mole}} \right) \right] T_R(491.67)}$$

$$R = 10.73151 \text{ psi} \cdot \text{ft}^3/\text{mole} \cdot \text{T}(^{\circ}R)$$

To obtain the density, note that density is mass per volume, so it is given as:

$\rho = \frac{m}{V}$ , and using the equation of state for the ideal gas:

$$\rho = \frac{m}{V} = \frac{nM}{nRT/P} = \frac{PM}{RT}$$

Using  $M = G \times M_{air}$ , the gas density equation is:

$$\rho = \frac{PGM_{air}}{RT}$$

Now calculate the density of the ideal gas.

For USC units:

$$\rho \left( \frac{lb_m}{ft^3} \right) = \frac{P(\text{psi}) \times G \times 28.96247}{10.73151 \times T(^{\circ}\text{R})}$$

$$\rho \left( \frac{lb_m}{ft^3} \right) = 2.698883 \frac{P(\text{psi})G}{T(^{\circ}\text{R})}$$

For SI units:

$$\rho \left( \frac{kg}{m^3} \right) = \frac{P(\text{kPa}) \times G \times 28.96247}{8.31447 \times T(\text{K})}$$

$$\rho \left( \frac{kg}{m^3} \right) = 3.48338 \frac{P(\text{kPa})G}{T(\text{K})}$$

These simple equations allow the calculation of the gas density knowing the gas specific gravity, pressure, and temperature.

### 2.2.7.3 Gas Compressibility

What is needed for a real gas? Since gas molecules are not point masses and have different shapes and sizes, the interaction between molecules is only partially due to kinetics. Molecular forces and the contribution of these two forms of energy transfer cause the relationship between pressure, temperature, and volume to diverge. The result is that the equation of state is an approximation for gases at higher pressures and low temperatures. There is a need to correct the ideal gas law to get the real gas law equation. For the real gas, the equation of state is rearranged as:

$$\frac{PM}{\rho RT} = z$$

Where:

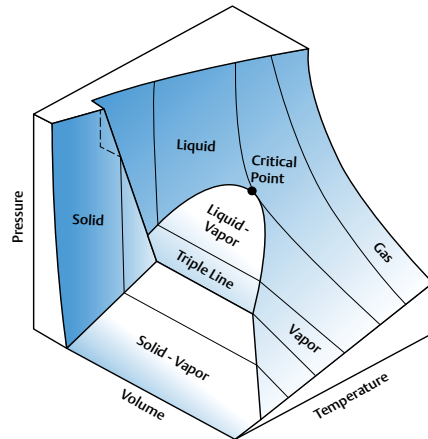
$z$  Compressibility factor

The equation of state for density for a real gas is then:

$$\rho = \frac{PM}{zRT}$$

The compressibility factor is a dimensionless number defined by the type of gas and varies with pressure and temperature. For an ideal gas, the compressibility factor is one. The value of the compressibility factor gives an indication of how far the gas deviates from the ideal state. For example, a gas at given conditions with a compressibility factor of 0.98 would have a 2% deviation in density from the ideal state at those conditions. However, for many gas flow applications, with nominal values of pressure and temperature less than 300 psi (2000 kPa) and greater than 60 °F (15 °C), the compressibility can be ignored. Extensive studies of pure substances (i.e., fluids containing matter of the same combination of atomic number) have produced data that gives the value of the compressibility for given values of pressure and temperature. The values of  $P$ ,  $V$ , and  $T$  can be plotted on a 3D chart called a P-V-T diagram. [Figure 2.7](#) shows a P-V-T diagram for water.

**Figure 2.7: P-V-T diagram for water.**

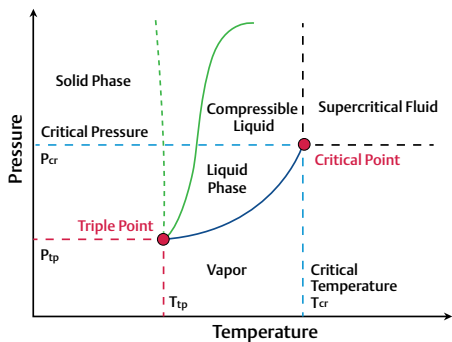


The data collected on gases produced an understanding of gas compressibility that could predict the compressibility of any gas if the values of critical pressure,  $P_c$ , and the critical temperature,  $T_c$ , were known. This understanding is called the law of corresponding states, and it was discovered by Johannes Diderik van der Waals, a Dutch theoretical physicist, in 1873. [Figure 2.8](#) shows a 2D plot of the pressure and



temperature axes from the P-V-T diagram. The region in the gaseous phase below the critical point can predict the compressibility knowing the fluid critical point. *Figure 2.9* shows a plot of the compressibility factor for many types of gases vs. the reduced pressure ( $P_r = P/P_c$ ), with lines that represent the reduced temperature ( $T_r = T/T_c$ ). Different gases have the same compressibility given the same reduced pressure and temperature values. These plots have been curve-fitted to equations that are used in flow computers to continually calculate the compressibility and density of many types of gases. *Table 2.5* shows the critical temperatures and pressures of many common gases used in the process control industry.

**Figure 2.8:** The P-T plot for a substance showing the critical point.

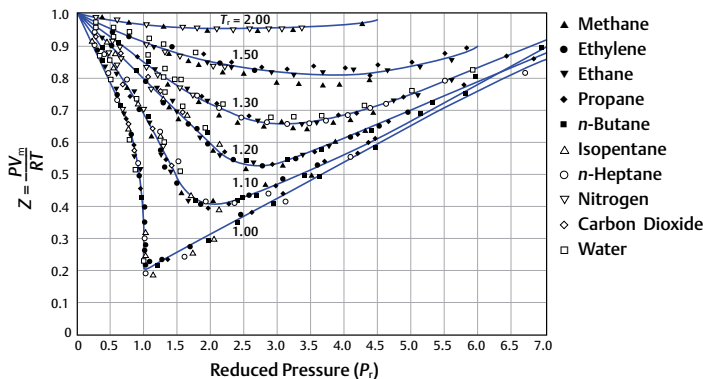


Although gaseous water (i.e., steam) is shown in *Figure 2.9*, the true density of steam was determined beginning in the 19th century. The extensive use of steam engines and turbines to power vehicles and electric generators required an understanding of steam properties. By the early 1930s, steam tables were commonly used and provided the steam density and viscosity for saturated and superheated steam over a wide range of pressures and temperatures.

### 2.2.8 Gas Mixtures

The gases found in industrial processes are often mixtures of two or more pure gases. The primary example of this is natural gas. The natural gas coming from a gas well is made up of many constituent gases. During processing, different sources of gas become mixed, and the final product gas mixture must be tested for the quantities of each gas contained. Accurate measurement of a flowing gas mixture requires the true density of the mix. The portion of each mixture component is also needed to determine the heat content of the gas. Fortunately, a widely used instrument called a gas chromatograph does just that. Current versions of these instruments combine gas chromatography with quadrupole mass spectrometry to provide a more complete and accurate analysis of gas samples.

**Figure 2.9:** The law of corresponding states provides values of the compressibility,  $z$ , knowing the reduced pressure and temperature.



**Table 2.5: Critical properties for some gases.**

Gas	Critical Temperature		Critical Pressure	
	°F	°C	psi	bar
Air	-220.94	-140.52	549.08	37.858
Ammonia	270	132.4	1636	112.8
Argon	-188	-122	705.6	48.7
Butane	305.6	152	550.4	38
Carbon Dioxide	87.8	31.2	1071.6	73.8
Carbon Monoxide	-220.5	-140.3	507.5	35
Chlorine	291	144	1118.7	77.1
Decane	653	345	301.7	20.8
Ethane	90	32.2	708	48.9
Ethanol	467	242	914	63
Ethylether	381	194	522	36
Ethylene	48.9	9.4	735	50.7
Fluorine	-200	-129	808.5	55.8
Helium	-456	-271	33.2	2.3
Hexane	454.1	234.5	438	30.2
Hydrogen	-400	-240	188.2	13
Hydrogen Chloride	125	51.6	11989	82.7
Isobutane	274	135	529.2	36.5
Isobutylene	293	145	580	40
Isononane	590	310	335.1	23.1
Isopentane	370	187.8	370	32.9
Methane	117	-82.6	673.3	46.5
Nitrogen	-232.6	-147	492.4	34
Nitrous Oxide	97.4	36.4	1047.6	72.3
Oxygen	-181.5	-118.6	732	50.5
Pentane	386	196.7	487	33.2
Propane	206.1	96.7	617.4	42.6
Water	705	374	3206.2	220.5

When a sample of a gas mixture is analyzed, a list of gases and the volume (mole) fractions are given. Since the sampling is done at low pressure and room temperature, no compressibility values are typically needed, and the same equation used for a liquid mixture can be used for gases:

$$\rho_{mix} = \sum x_i \rho_i$$

To allow using the gas specific gravity:

$$G_i = \frac{\rho_i}{\rho_{air}} = \frac{M}{M_{air}} \text{ so that: } G_{mix} = \sum x_i G_i$$

Table 2.6 shows a typical natural gas analysis with the mole or volume fractions given for 11 component gases. Using the equation above, the specific gravity of this natural gas is 0.5620.

**Table 2.6: Example of natural gas components.**

Gas Component	Mole Fraction, $X_i$ , %	Specific Gravity, $G_i$	$X_i G_i$
Methane	93.19	0.554	0.5163
Ethane	4.5	1.038	0.0467
Propane	0.50	1.522	0.0076
Isobutane	0.03	1.940	0.0006
Butane	0.03	2.006	0.0006
Isopentane	0.01	2.480	0.0002
Pentane	0.01	2.487	0.0002
Hexanes	0.01	2.973	0.0003
Nitrogen	1.20	0.967	0.0116
Carbon Dioxide	0.50	1.519	0.0076
Oxygen	0.02	1.104	0.0002

### 2.2.8.1 Compressibility of a Gas Mixture

Now that the gas gravity of a mixture can be calculated, to get an accurate density requires the compressibility of the mixture. There have been many methods developed for calculating the compressibility factor or the actual density of the real gas. The natural gas industry has published standards or reports with increasingly more accurate methods for obtaining the

compressibility of natural gas. The American Gas Association (AGA) published report NX-19 in 1962, which provided a method to calculate the compressibility of typical natural gas types. This method was limited to certain concentrations of trace gases. The need for better accuracy for more types of natural gas generated a new method to calculate compressibility, which was published as AGA Report No. 8 in 1985, with an updated version published in 1992. The most recent versions of this standard allowed a large range of constituent gases with some up to 100%, which means the compressibility of the pure gases methane, nitrogen, carbon dioxide, ethane, and hydrogen could be calculated.

The complexity of the compressibility equations requires digital computation systems. However, a simple method will be shown here. Compressibility can be closely estimated by getting the composite reduced pressure and temperature of the mixture and using the same chart shown in [Figure 2.8](#). A close approximation of these values is determined using a method developed by Webster B. Kay in 1936. Kay worked for Standard Oil at the time and needed a method to approximate the density of gas mixtures. The method was later called Kay's Rule, and is given by:

$$T_{c-mix} = x_1 T_{c1} + x_2 T_{c2} + x_3 T_{c3} + \dots + x_n T_{cn}$$

For the critical temperature of the gas mixture, and

$$P_{c-mix} = x_1 P_{c1} + x_2 P_{c2} + x_3 P_{c3} + \dots + x_n P_{cn}$$

For the critical pressure of the mixture made up of  $n$  constituent gases.

Where:

- $x_i$       Volume or mole fraction of the  $i$ th gas
- $T_{ci}$      Critical temperature of the  $i$ th gas, °R (K)
- $P_{ci}$      Critical pressure of the  $i$ th gas,  $psi$  (kPa)

These values are then used to obtain the reduced pressure and temperature of the gas mixture, and the compressibility of the gas mixture is then obtained using the law of corresponding states chart.

### Example:

Calculate the compressibility and gas density of a natural gas.

Using the information in [Table 2.6](#), calculate the compressibility factor if the given gas is at a pressure of 500 psia (34.47 bar) and 70 °F (21 °C) using Kay's Rule.

Using [Table 2.5](#) for the critical values of each gas, [Table 2.7](#) shows the critical values for the natural gas mixture. The critical pressure for the natural gas is 674.3 psi (46.49 bar), and the critical temperature is 354 °R (196.7 K). The reduced pressure is then  $500/674.3 = 0.74$ , and the reduced temperature is then  $(70 + 460)/354 = 1.5$ . Using the chart in [Table 2.8](#) provides a compressibility value of  $z = 0.93$ .

For the values of the specific gravity and compressibility in the example, calculate the natural gas density.

The equation in [Section 2.2.7.2](#) for USC units with the compressibility factor included is used:

$$\rho = \frac{2.69883 \times 500 \times 0.562}{0.93 \times 530} = 1.538 \left( \frac{lb_m}{ft^3} \right)$$

## 2 – Fluids and Flow Basic Terms and Concepts

Table 2.7: Compressibility of a natural gas using Kay's Rule.

Gas Component	$X_i$ - %	$P_c$ , psi	$T_c$ , R	$X_i \times P_c$	$X_i \times T_c$
Methane	93.19	673.3	343	627.4	319.6
Ethane	4.50	708.0	550	31.9	24.8
Propane	0.50	617.4	666.1	3.1	3.3
Isobutane	0.03	529.2	734	0.2	0.2
Butane	0.03	550.4	765.6	0.2	0.2
Isopentane	0.01	370.0	830	0.0	0.1
Pentane	0.01	487.0	846	0.0	0.1
Hexane	0.01	438.0	914.1	0.0	0.1
Nitrogen	1.20	492.4	227.4	5.9	2.7
Carbon Dioxide	0.50	1071.6	547.8	5.4	2.7
Oxygen	0.02	732.0	278.5	0.1	0.1
				$P_{c\text{-mix}} =$	674.3
				$T_{c\text{-mix}} =$	354.0

## 2 – Fluids and Flow Basic Terms and Concepts

Table 2.8: Specific heats  $C_p$  and  $C_v$  for various gases at 68 °F (20 °C) and 14.696 psi (101.325 kPa).

Gas or Vapor	Formula	$C_p$ , BTU/lb <sub>m</sub> /F (kJ/(kg/K))	$C_v$ , BTU/lb <sub>m</sub> /F (kJ/(kg/K))	$K=C_p/C_v$
Acetone	(CH <sub>3</sub> ) <sub>2</sub> CO	0.35 (1.47)	0.32 (1.32)	1.11
Acetylene	C <sub>2</sub> H <sub>2</sub>	0.35 (1.69)	0.27 (1.37)	1.232
Air	–	0.24 (1.01)	0.17 (0.72)	1.4
Alcohol (ethanol)	C <sub>2</sub> H <sub>5</sub> OH	0.45 (1.88)	0.40 (1.67)	1.13
Alcohol (methanol)	CH <sub>3</sub> OH	0.46 (1.93)	0.37 (1.53)	1.26
Ammonia	NH <sub>3</sub>	0.52 (2.19)	0.40 (1.66)	1.31
Argon	Ar	0.12 (0.52)	0.07 (0.31)	1.667
Benzene	C <sub>6</sub> H <sub>6</sub>	0.26 (1.09)	0.24 (0.99)	1.12
Blast Furnace Gas	–	0.25 (1.03)	0.17 (0.73)	1.41
Bromine	Br <sub>2</sub>	0.06 (0.25)	0.05 (0.20)	1.28
Butane	C <sub>4</sub> H <sub>10</sub>	0.40 (1.67)	0.36 (1.53)	1.094
Carbon Dioxide	CO <sub>2</sub>	0.21 (0.84)	0.16 (0.66)	1.289
Carbon Monoxide	CO	0.24 (1.02)	0.17 (0.72)	1.4
Carbon Disulphide	CS <sub>2</sub>	0.16 (0.67)	0.13 (0.55)	1.21
Chlorine	Cl <sub>2</sub>	0.12 (0.48)	0.09 (0.36)	1.34
Chloroform	CHCl <sub>3</sub>	0.15 (0.63)	0.13 (0.55)	1.15
Coal Gas	–	0.00 (2.14)	0.00 (1.59)	–
Ethane	C <sub>2</sub> H <sub>6</sub>	0.39 (1.75)	0.32 (1.48)	1.187
Ether	(C <sub>2</sub> H <sub>5</sub> ) <sub>2</sub> O	0.48 (2.01)	0.47 (1.95)	1.03
Ethylene	C <sub>2</sub> H <sub>4</sub>	0.40 (1.53)	0.33 (1.23)	1.24
Helium	He	1.25 (5.19)	0.75 (3.12)	1.667
Hexane	C <sub>6</sub> H <sub>14</sub>	0.00 (0.00)	0.00 (0.00)	1.06
Hydrogen	H <sub>2</sub>	3.42 (14.32)	2.43 (10.16)	1.405
Hydrogen Chloride	HCl	0.19 (0.80)	0.14 (0.57)	1.41
Hydrogen Sulfide	H <sub>2</sub> S	0.24 (0.00)	0.19 (0.00)	1.32
Methane	CH <sub>4</sub>	0.59 (2.22)	0.45 (1.70)	1.304
Natural Gas	–	0.56 (2.34)	0.44 (1.85)	1.27
Neon	Ne	0.00 (1.03)	0.00 (0.62)	1.667
Nitric Oxide	NO	0.23 (1.00)	0.17 (0.72)	1.386
Nitrogen	N <sub>2</sub>	0.25 (1.04)	0.18 (0.74)	1.4
Nitrous Oxide	N <sub>2</sub> O	0.21 (0.88)	0.17 (0.69)	1.27
Oxygen	O <sub>2</sub>	0.22 (0.92)	0.16 (0.66)	1.395
Pentane	C <sub>5</sub> H <sub>12</sub>	0.00 (0.00)	0.00 (0.00)	1.07
Propane	C <sub>3</sub> H <sub>8</sub>	0.39 (1.67)	0.34 (1.48)	1.13
Propylene	C <sub>3</sub> H <sub>6</sub>	0.36 (1.50)	0.31 (1.31)	1.15
Steam 1 Bar, 104 - 316 °C	H <sub>2</sub> O	0.47 (1.97)	0.36 (1.50)	1.31
Steam 10 Bar, 182 - 216 °C	H <sub>2</sub> O	0.54 (2.26)	0.42 (1.76)	1.28
Sulfur Dioxide	SO <sub>2</sub>	0.15 (0.64)	0.12 (0.51)	1.29

### 2.2.9 Humidity

Humidity is the measure of water vapor in atmospheric-pressure air and will affect the calculated flow rate for air flow meter applications. The level of humidity will affect the air density, and the amount of water vapor that can be held in the air depends on the temperature. Humid air is a mixture of gases, and the equation for calculating the specific gravity,  $G_{wet}$ , of the humid air is:

$$G_{wet} = \left[ 1 - \frac{0.3780 p_{wv}}{p_f} \right]$$

Where:

$P_{wv}$  Partial pressure of the water vapor

$P_f$  Absolute pressure of the air

The partial pressure of the water vapor is the pressure that the water vapor would exert if air was removed. If the relative humidity is known, the partial pressure of the water vapor is:

$$P_{wv} = RH \times P_{sat}(T)$$

Where:

$P_{sat}(T)$  Saturation pressure at the flowing temperature

The saturation pressure is obtained from the steam tables in [Chapter 6](#) at the operating pressure of the system. Refer to [Chapter 4](#) for more information on humid air flows and examples.

### 2.2.10 Gas Specific Heats and the Isentropic Ratio

The specific heat of a substance defines how much energy is absorbed by the fluid molecules per degree of temperature or unit of pressure. There are two specific heats:

- $C_v$  — Prescribes the change in energy at a constant volume
- $C_p$  — Prescribes the change in energy at a constant pressure, which provides a method to more simply evaluate the energy changes for a system

Note: The derivations shown here assume that the specific heats are constant values, represented by the simpler  $\Delta$  symbol rather than the differential symbol which is needed for the general form.

The relationship between the change in internal energy of a substance,  $\Delta u$ , given a change in temperature gives the first specific heat,  $c_v$ , which is the change in energy of a defined system per unit mass per degree of temperature at a constant volume:

$$\Delta u = c_v \Delta T$$

Where:

- $c_v$  Specific heat at constant volume of a pure substance,  $BTU/lb_m \cdot ^\circ R$  ( $J/kg \cdot K$ )
- $\Delta u$  Substance internal energy change,  $BTU$  ( $J$ )
- $\Delta T$  Change in substance temperature,  $^\circ R$  ( $K$ )

The second specific heat gives the change in total energy of a substance (i.e., enthalpy) in a defined system per unit mass per degree of temperature at constant pressure,  $c_p$ , and has the same units as  $c_v$ :

$$\Delta h = c_p \Delta T$$

Where:

$\Delta h$  Change in enthalpy of a system, which is the change in internal energy and pressure work, or,  $\Delta h = \Delta u + p\Delta V$

$c_p$  Specific heat at constant pressure of a pure substance,  $BTU/lb_m \cdot ^\circ R$  ( $J/kg \cdot K$ )

These concepts may seem abstract but are fundamental when using the conservation of energy principle to predict the values of pressure and density when a gas flows through or around a DP primary element. An interesting point about these values is that per mole of an ideal gas, the difference in the two specific heats per mole equals the universal gas constant:

$$c_p = \frac{\Delta u}{\Delta T} + P \frac{\Delta V}{\Delta T} = c_v + R$$

This means that once one of the specific heat values is determined, the other can be calculated. The specific heats of many pure substances have been measured, and some values are shown in [Table 2.8](#). It is also true that for an isentropic process (i.e., reversible with no heat added):

$$\Delta q(\text{heat}) = 0 = \Delta u + p\Delta v = c_v \Delta T + p\Delta v, \text{ or}$$

$$c_v \Delta T = -p\Delta v$$

The enthalpy (total energy change) of a gas is:

$$\Delta h = c_p \Delta T = \Delta u + p\Delta v + v\Delta p, \text{ but for the isentropic case: } \Delta u + p\Delta v = 0$$

$$\text{So that: } c_p \Delta T = v\Delta p$$

Dividing the equations for  $c_p$  by  $c_v$  gives:

$$\frac{c_p}{c_v} = -\frac{v \Delta p}{p \Delta v}, \text{ and } \frac{\Delta p}{p} + \frac{c_p \Delta v}{c_v v} = 0$$

The solution to this equation is:

$$pv^k = \text{constant}, \text{ where } = \frac{c_p}{c_v}$$

This is called the isentropic ratio, or specific heat ratio. This concept can be used to predict the amount of pressure change at the downstream tap of a DP flow primary element due to the expansion of an ideal gas. It also provides the means to characterize this change for different types of DP primary elements used for measuring real gas flows.

### 2.2.11 Viscosity

Absolute viscosity defines the resistance of a fluid to movement or flow. It is a measure of how the fluid molecules react to a sheer or tensile stress. Stated differently, the viscosity of a fluid describes the friction that is caused when layers of fluid attempt to slide against one another. The greater the viscosity, the greater the friction. Absolute viscosity is defined as:

$$\mu = \frac{\tau}{\delta v / \delta y}$$

Where:

$$\mu \quad \text{Absolute viscosity, } \frac{lb_f / ft^2}{\frac{ft}{sec} / ft} = \frac{lb_f}{ft^2 \cdot sec}$$

$$\left( \frac{N/m^2}{\frac{m}{sec} / m} = \frac{N}{m^2 \cdot sec} \text{ or } Pa \cdot sec \right)$$

$t$  Shearing stress in the fluid, or the force required to move the fluid against a surface per unit area

$\frac{\delta v}{\delta y}$  Change in velocity, or the strain between the wall or surface and the free-stream velocity per unit length

This relationship is shown in *Figure 2.10*. The units for viscosity are stress/strain but are converted to inertial force units so that viscosity units in the Reynolds number equation will be the same as the dynamic force units, making the Reynolds number dimensionless. This is done by multiplying the force viscosity by the inertial force conversion constant,  $g_c$ , to obtain the inertial mass viscosity:

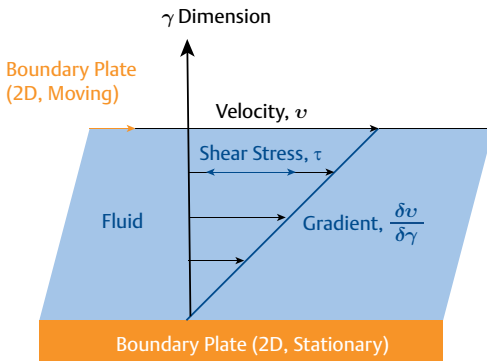
$$\mu_f \left( \frac{\text{lb}_f \cdot \text{sec}}{\text{ft}^2} \right) \times g_c (\text{lb}_m \cdot \text{ft} / (\text{lb}_f \cdot \text{sec}^2)) = \mu_m (\text{lb}_m / \text{ft} \cdot \text{sec})$$

for USC units, and

$$\mu_f \left( \frac{\text{N} \cdot \text{sec}}{\text{m}^2} \right) \times g_c (\text{kg} \cdot \text{m} / (\text{N} \cdot \text{sec}^2)) = \mu_m (\text{kg} / \text{m} \cdot \text{sec})$$

for SI units

**Figure 2.10: Viscosity defines the resistance to movement of a fluid.**



Since water is the reference liquid, the viscosity of water is well known. The viscosity of water at 68 °F (20 °C) is 0.000672  $\text{lb}_m/\text{ft}\cdot\text{sec}$  (10.019  $\text{kg}/\text{m}\cdot\text{sec}$ ).

The most commonly used units for viscosity are the poise (P),  $\text{g}/\text{cm}\cdot\text{sec}$ , the centipoise (cP), or 100 poise, which has the units  $100 \text{ g}/\text{cm}\cdot\text{sec}$ . The viscosity of water at 68 °F (20 °C) is 1 cP. Since the value is 1 for the reference substance at a reference temperature, the centipoise is the more common unit of viscosity for both unit conventions and conversions used in the equations that require viscosity (i.e., Reynolds number) to convert centipoise to other units.

The value of viscosity goes down as the water temperature increases. *Table 2.9* shows the viscosity of water from 33 to 210 °F (0.56 to 98.89 °C).

**Table 2.9: Viscosity of water by temperature.**

Temperature		Viscosity	
°F	°C	Dynamic, cP	Kinematic, cS
33	0.56	1.717	1.717
35	1.67	1.658	1.658
40	4.44	1.522	1.522
45	7.22	1.403	1.403
50	10.00	1.296	1.297
55	12.78	1.202	1.203
60	15.56	1.117	1.119
65	18.33	1.042	1.043
68	20.00	1.000	1.002
70	21.11	0.974	0.976
75	23.89	0.912	0.915
80	26.67	0.856	0.859
85	29.44	0.806	0.809
90	32.22	0.760	0.764
100	37.78	0.679	0.684
110	43.33	0.612	0.617
120	48.89	0.554	0.561
130	54.44	0.505	0.513
140	60.00	0.463	0.471
150	65.56	0.426	0.435
160	71.11	0.394	0.403
170	76.67	0.366	0.376
180	82.22	0.342	0.351
190	87.78	0.320	0.329
200	93.33	0.300	0.309
210	98.89	0.283	0.291



Another unit of viscosity is the kinematic viscosity,  $\nu$ , and it is related to the dynamic viscosity by:

$$\nu = \frac{\mu}{\rho}$$

Where:

$\nu$  Kinematic viscosity,  $ft^2/sec$  ( $m^2/sec$ )

$\rho$  Density,  $lb_m/ft^3$  ( $kg/m^3$ )

The more commonly used unit for kinematic viscosity is the stoke (St) or centistoke (cSt), which is related to the poise or centipoise by:

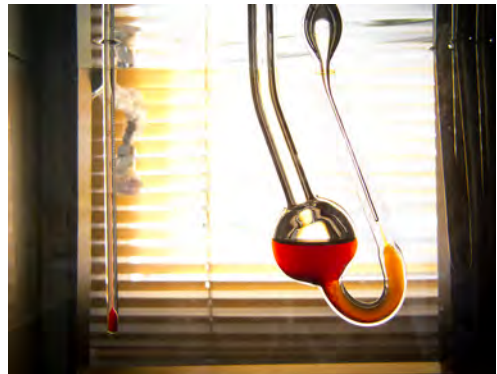
$$\nu(\text{stoke}) = \mu(\text{poise}) \times \rho \left( \frac{g}{cm^3} \right)$$

$$\nu(\text{centistoke}) = \mu(\text{centipoise}) \times \rho \left( \frac{g}{cm^3} \right)$$

For water, the density in  $g/cm^3$  is 1 at room temperature, so the absolute and dynamic viscosity are nearly the same value.

A viscometer can be used to determine the fluid viscosity by measuring the time it takes a specific volume of liquid to flow through a capillary or hole in a cup. The simplest viscometer for determining a liquid viscosity uses a supply and receiving volume with a capillary tube in between. A precise quantity of liquid flows through the capillary, and the time required for a quantity of the fluid to flow through the capillary is recorded. These types of viscometers typically determine the kinematic viscosity of the liquid. [Figure 2.11](#) shows a glass-capillary viscometer called an Ostwald viscometer. Since the temperature affects the viscosity directly, it is usually immersed in a temperature-controlled bath while in use.

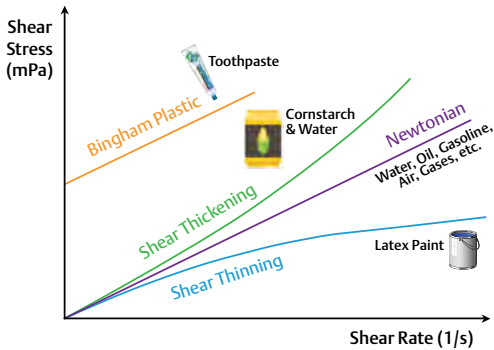
**Figure 2.11: Ostwald capillary viscometer.**



Every real fluid has viscosity, which changes primarily with temperature. For this reason, fluid viscosity is usually plotted against temperature, and equations are developed that allow the calculation of viscosity once the temperature is known. For a liquid, the viscosity decreases with temperature; for a gas, the viscosity increases with temperature.

[Figure 2.12](#) shows the plot for different types of fluids based on this behavior. Fluids where the viscosity is constant with the stress/strain ratio show as a line on the chart and are called Newtonian fluids. The slope of the line is the viscosity of the fluid. Fluids with a different relationship are referred to as non-Newtonian fluids. Shear-thinning fluid viscosities decrease with increasing shear stress (e.g., ketchup, lava polymer solutions, and molten polymers). Shear thickening fluid viscosities (with viscosity increasing as shear stress increases) include suspensions (e.g., corn starch in water). Bingham plastics do not flow until a critical stress yield is exceeded (e.g., toothpaste). DP flow meters are best suited for measurement of Newtonian fluids since the viscosity is a constant over the range of flow rate and can be simply determined.

**Figure 2.12: Fluid classification based on the behavior of viscosity.**



### 2.3 Fluid Flow Basics

Flow is the measure of fluids in motion, specifically in some type of conduit. A fluid can be either a liquid or a gas. Open-channel flow is liquid flow in a canal, ditch, or riverbed. Closed channel flow is flow in an enclosed pipe, duct, or culvert. The measurement of the flow rate can be done using many types of flow meters. Some types of flow meters used today are DP, turbine, vortex, magnetic, ultrasonic, positive displacement, variable area, and Coriolis flow meters. Many of these meter types measure the velocity of the fluid either directly (ultrasonic, vortex, and magnetic) or indirectly (DP, turbine, and variable area). The positive displacement meter measures volume flow directly by capturing a portion of fluid in a rotating drum and counting each rotation. The mass flow rate provides the most basic of flow values as it is unaffected by changes in the fluid condition. There are a few flow meters that respond to mass flow rate directly, Coriolis being the primary mass flow rate meter.

To understand flow measurement, the relationship between velocity, volumetric, and mass flow rates is needed.

#### 2.3.1 Velocity

Velocity,  $v$ , as applied to fluid dynamics, defines the speed of a particle of fluid with respect to a stationary reference such as a pipe. Common units are ft/s (m/s). When calculating the flow rate in a pipe using velocity, the average velocity at the measuring plane,  $\bar{V}$ , is needed. When a real fluid flows around an object or through a pipe, the viscosity of the fluid creates a change in the velocity from the center to the walls of the pipe. Shearing between adjacent fluid particles in a viscous fluid produces a non-uniform velocity profile in the pipe. After a sufficiently long length of straight pipe, the velocity is zero at the pipe wall and maximum at the pipe axis, and it is symmetric around the pipe axis. This condition is called developed flow. See [Chapter 3](#) for more information.

#### 2.3.2 Actual Volumetric Flow

Actual volumetric flow,  $Q_A$ , defines how much volume of fluid is passing through a given area at the flowing conditions in the pipe. If the average velocity in the pipe,  $\bar{V}$ , is measured, the actual volumetric flow rate is:

$$Q_A = \bar{V} \times A$$

Where:

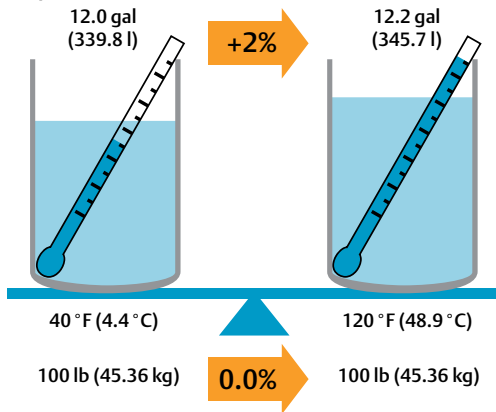
- $A$  Area of the pipe at the measuring location
- $\bar{V}$  Average pipe velocity

Common units used for actual volume flow rate are ACFM, ACFH, l/min, and m<sup>3</sup>/hr. See [Chapter 3](#) for more information.

#### 2.3.3 Mass Flow

Mass flow is dependent on the fluid density and the volumetric flow rate. Common units are lb<sub>m</sub>/hr (kg/hr). For a given quantity of fluid, mass does not change but volume can with changes in pressure and temperature. See [Figure 2.13](#). The measurement of mass flow is preferred for most fluids, while volumetric flow can be acceptable for applications where the change in fluid conditions is limited. See [Chapter 3](#) for more information.

**Figure 2.13: Mass does not change with a change in temperature, but volume does.**



### 2.3.4 Standard Volumetric Flow

Standard volumetric flow defines how much volume of fluid is passing through a given area at a standard or base pressure and temperature. Standard volume flow is calculated by dividing the mass flow rate by the density of the fluid at the reference (i.e., base) conditions, which is a constant. It is also sometimes referred to as normal volumetric flow outside of the U.S. Common units are SCFM, SCFH, NM<sup>3</sup>/h, and SL/hr. When reporting standard volumetric flow, it is important to define the reference conditions. Standards may vary by country and industry, although the references should typically be stated on the specification sheet for the flow meter. [Table 2.10](#) shows the reference conditions typically used in the process control industry. See [Chapter 3](#) for more information.

**Table 2.10: Standard volume reference conditions.**

Definition/Where Used	Reference Pressure	Reference Temperature
Normal Cubic Meter Non-U.S. Countries	101.325 kPa	0 °C
Standard Cubic Foot AGA Report No. 3	14.73 psia	60 °F
Standard Cubic Foot Other Industries	14.696 psia	60 °F
ISO 5024 – Standard Conditions for Petroleum Fluids	101.325 kPa 14.696 psia	15 °C 59 °F

## 2.4 DP Flow Basic Terms

The terms and parameters that define the DP flow meter are presented in this section. See [Chapters 3, 7, and 9](#) for more information.

### 2.4.1 DP Flow Components

The DP flow meter was introduced in [Chapter 1](#). In its simplest form, a DP flow meter consists of a differential pressure transmitter measuring the pressure drop across a primary element. Some sort of connection system is also required to connect the transmitter to the primary element. Refer to [Chapter 1](#) for additional descriptions of these components, or [Chapters 7, 8, and 9](#) for an in-depth look at the various configurations of these flow meters.

### 2.4.2 Differential Pressure

DP flow meters determine the flow rate from the pressure differential between the upstream (high) side and downstream (low) side of the DP flow primary element. Differential pressure was introduced in [Chapter 1](#), and the theory is derived in [Chapter 3](#).

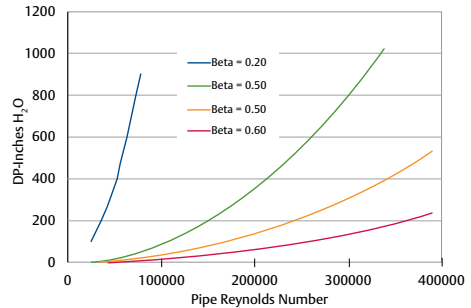
### 2.4.3 DP Flow Meter Sizing

The first step in engineering a DP flow measurement point is to perform a sizing. Historically, sizing a flow meter meant adjusting the bore for an orifice plate (or blockage for other DP elements) to provide a specific DP at a given flow rate. With the advent of the digital-based DP transmitter, sizing is more flexible and can be solved by adjusting the output of the differential pressure for a given flow rate, rather than sizing the bore of a primary element. Sizing programs can also do checks to ensure that the primary element selected will perform over the desired operating range and conditions. Some programs will also provide an estimate of the expected accuracy or total system performance of the specified meter. See [Chapters 7](#) and [9](#) for more information.

### 2.4.4 Pipe Blockage by the DP Flow Meter

Pipe blockage is a term that describes the inherent restriction of the fluid flow due to the presence of the DP flow meter. This effect becomes a key consideration when DP flow technology is used since the amount of blockage is related to the amount of pressure loss that will be produced by the primary element. The greater the amount of blockage, the higher the differential pressure. A higher DP provides a better resolution of the flow rate and is less affected by turbulence or noise in the flow field. Therefore, there can be a tradeoff between pressure loss and accuracy of the flow measurement. Typically, the higher the pressure loss, the better the accuracy. However, because pressure loss directly relates to energy lost and requires higher pumping costs, operating costs are reduced by choosing primary elements that have less pipe blockage. [Figure 2.14](#) shows the difference in DP for an orifice plate in a typical water application by beta.

**Figure 2.14: Reynolds number vs. DP for a concentric orifice plate in a 6-in. (150 mm) water flow by beta.**



For orifice plate technology, the amount of blockage is expressed as the beta ratio,  $\beta$ . The beta ratio is defined as the ratio of the orifice bore diameter,  $d$ , to the internal pipe diameter,  $D$ , shown in [Figure 2.15](#).

**Figure 2.15: Area meter beta ratio.**



Beta is used in the derivation of the DP meter flow equation for an area meter in [Chapter 3](#). For other DP primary element technologies, such as the wedge primary element and cone meter, the blockage can also be determined and is sometimes related back to the equivalent circular bore,  $d_{eq}$ , and the equivalent beta ratio,  $\beta_{eq}$ . See [Chapter 7](#) for this relationship for various DP primary elements.

For the averaging pitot tube, there is also a blockage function, although the effect is much smaller than for the orifice plate. Blockage is given as the projected area of the averaging pitot tube cylinder divided by the pipe area:

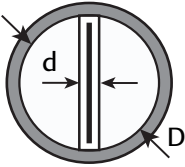
$$B = a(\text{cylinder})/A(\text{pipe})$$

Shown in Figure 2.16, the cylinder area,  $a = dxD$ , and the pipe area is:  $A = \frac{\pi D^2}{4}$ , so the blockage,  $B$ , for a circular pipe is then:  $B = \frac{4 \times d}{\pi \times D}$

Where:

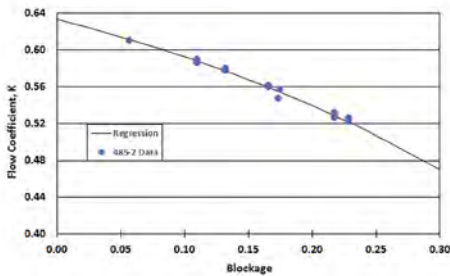
$B$	Blockage
$d$	Width of the cylinder or sensor
$D$	Diameter of the pipe

**Figure 2.16: Averaging pitot tube blockage.**



The blockage becomes the geometry that is used to predict the value of the flow coefficient for a given size of averaging pitot tube sensor and the pipe size. [Figure 2.17](#) shows a plot of the flow coefficient against the blockage for a typical averaging pitot tube. See [Chapter 7](#) for more information.

**Figure 2.17: Flow coefficient vs. blockage data.**



### 2.4.5 Discharge Coefficient

The discharge coefficient,  $C$ , relates the true flow rate for real fluids to the theoretical flow rate calculated using theoretical DP flow equations for an ideal fluid and is used in the area meter flow equation. The discharge coefficient is always less than one and accounts for the effects of viscosity on the flow meter. See [Chapter 3](#) for more information.

### 2.4.6 Flow Coefficient

The flow coefficient,  $K$ , is similar to the discharge coefficient for an area meter in that it relates the true flow rate to the theoretical flow rate, is always less than one, and is found in the flow equation for pitot and averaging pitot tubes. The flow coefficient accounts for the effects of viscosity and the blockage created by the averaging pitot tube in the pipe. See [Chapters 3](#) and [7](#) for more information.

### 2.4.7 Flow and DP Turndown

Flow turndown is defined as the ratio of the maximum flow rate in an application divided by the minimum flow rate. This term is useful in describing the required measurement range for a flow application. Flow meter manufacturers also utilize flow turndown to describe the measurement capability of their devices and the range over which flow meter performance specifications apply. In this case, the maximum flow rate is typically the highest flow rate that the flow meter can measure.

The DP at the maximum flow rate divided by the DP at the minimum flow rate is called the DP turndown. It is not the same as the flow turndown. See [Chapters 7](#) and [8](#) for more information.

### 2.4.8 Accuracy

Flow meter accuracy is defined as how close a measured value is to the accepted or true value. Typically, accuracy is expressed as either a percent of span or percent of rate. When the flow rate is calculated from individual measurements, as it is for a DP flow meter, the accuracy of the calculated flow rate depends on the sensitivity of the flow rate to the measured variables in the DP flow equation. The sensitivity defines the effect that a change in a variable has on the overall measurement. See [Chapter 7](#) for more information on accuracy and sensitivity.

## 2.5 Applicable Flow Meter Standards

There are some published standards for flow meters:

1. ISO 6976:2016 Natural gas — Calculation of calorific values, density, relative density and Wobbe index from composition
2. ISO 12213:2006 Natural gas — Calculation of compression factor
3. ISO 15970:2008 Natural gas — Measurement of properties — Volumetric properties: density, pressure, temperature and compression factor
4. AGA Report No. 8: Part 1, Thermodynamic Properties of Natural Gas and Related Gases, DETAIL and GROSS Equations of State, 2017
5. ITS-90 Density of Water Formulation for Volumetric Standards Calibration, Journal of Research of the National Institute of Standards and Technology, Volume 97, Number 3, May-June 1992
6. ASME Steam Tables-Compact Edition, 2006

# 3

## Theory of DP Flow

	<b>Topic</b>	<b>Page</b>
3.1	Introduction	40
3.2	Energy of a Fluid in Motion	40
3.3	Specific Forms of the Fluid Energy Equation	42
3.4	The Energy Equation for the DP Flow Meter	43
3.5	Theoretical and True Fluid Flow Equations	45
3.6	The Practical DP Flow Equations	46
3.7	Reynolds Number and the Velocity Profile	50
3.8	Developed and Undeveloped Flows	54
3.9	Compressible Flow	56
3.10	Applicable Flow Meter Standards	60
3.11	Additional Information	60

### 3.1 Introduction

The differential pressure (DP) flow meter is based on fundamental physical laws. This chapter begins with the primary theories presented in [Chapter 1](#) and derives the equations used to calculate the flow rate for the two types of DP flow meters. The limitations and changes to these equations because of real fluid viscosity and gas compressibility are introduced. While the underlying math can be complex for DP flow, sizing software and modern electronics can handle these calculations with ease.

### 3.2 Energy of a Fluid in Motion

The study of fluids in motion is a complex problem, and a general solution is very difficult to provide. This is primarily because there are many variables that interact and must be defined in three dimensions. Energy in a fluid flow is defined by sets of complex multivariable equations. However, it is possible to simplify energy for pipe flow by making two assumptions. First, pipe flow is a one-dimensional problem: the fluid must travel down the pipe axis. Second, the effects of fluid viscosity can be ignored. With these assumptions, it is possible to reduce the initially complex equation set to a simple model for fluid flow. DP flow theory is based on the conservation of energy. This fundamental rule states that energy is neither created nor destroyed and can only be changed. This change is done by defining the forms of energy contained in a fluid and is expressed as an equation, which is shown in [Section 3.2.5](#).

The primary definition of energy is a force applied over a distance, which is also called work. Two of the basic forms of energy are kinetic energy, which is the energy of a body in motion, and potential energy, or the energy that is stored and will become kinetic energy when released. Some examples of potential energy are a rock sitting at the top of a cliff, a tank under pressure, and a coil spring that is compressed. To kinetic and potential energy, we add the internal or thermal

energy of the fluid. In comparing liquid and solid bodies in motion, an important distinction must be made with fluids: the measure of the different forms of energy are given per unit mass. This is because fluid is a media, and the amount of fluid depends on the size of the container or pipe. To get a measure of the energy of a moving fluid, it is more fundamental to use the properties of the fluid per unit mass. Due to the simplifications for the pipe flow model stated above, the differential form of the equations governing fluid energy are unnecessary and can be represented using the algebraic equations that follow.

#### 3.2.1 The Kinetic Energy of a Fluid

Fluid kinetic energy ( $KE$ ) is given by:

$$KE = V^2 / 2g_c$$

Where:

$V$  Fluid velocity, ft/sec (m/sec)

$g_c$  Inertial force conversion constant,  
32.174 lb<sub>m</sub> · ft / (lb<sub>f</sub> · sec<sup>2</sup>) (1 kg · m / (N · sec<sup>2</sup>))

When the units are combined, they are:

lb<sub>f</sub> · ft / lb<sub>m</sub> (J/kg), or energy per unit mass

For the ideal fluid, the velocity is constant everywhere in the pipe, but for a real fluid, the velocity has a profile that depends on the Reynolds number. The true kinetic energy for a real fluid is higher than for the ideal fluid using the previous equation. See [Section 3.7.2](#).





### 3.2.2 The Body Energy of a Fluid

Body (gravitational) energy (BE) of a fluid is given by:

$$BE = z g_l / g_c$$

Where:

$z$  Vertical distance,  $ft$  ( $m$ ) for a fluid above a given datum reference point, in a gravitational field. This accounts for the energy needed to pump a fluid to a higher point or the energy released when a fluid flows down from a high to a low point

$g_l$  Local acceleration of gravity,  $ft/sec^2$  ( $m/sec^2$ ), as gravity is not constant on the earth's surface

When the units for these values are combined using the equation, they are:

$$lb_f \cdot ft / lb_m \text{ (J/kg)}, \text{ or energy per unit mass}$$



### 3.2.3 The Pressure Energy of a Fluid

The pressure energy (PE) of a fluid accounts for the energy due to pressure of a fluid as it moves through a system. It is given by :

$$PE = p v_f = p / \rho$$

Where:

$p$  Fluid pressure,  $lb_f / ft^2$  ( $N/m^2 - pascal$ )

$v_f$  Fluid specific volume,  $ft^3 / lb_m$  ( $m^3 / kg$ )

$\rho$  Fluid density,  $lb_m / ft^3$  ( $kg / m^3$ )

When the units are combined, they are:

$$lb_f \cdot ft / lb_m \text{ (J/kg)}, \text{ or energy per unit mass}$$



### 3.2.4 The Internal Energy of a Fluid

Another form of energy is the thermal energy of the fluid, which is accounted for by the value of the internal fluid energy, and is given by:

$$IE = c_v T,$$

Where:

$c_v$  Coefficient of heat capacity at constant volume,  $lb_f \cdot ft / (lb_m \cdot ^\circ R)$  ( $J / (Kg \cdot K)$ )

$T$  Fluid temperature,  $^\circ R$  ( $K$ )

When the units are combined using the equation, they are:

$$lb_f \cdot ft / lb_m \text{ (J/kg)}, \text{ or energy per unit mass}$$



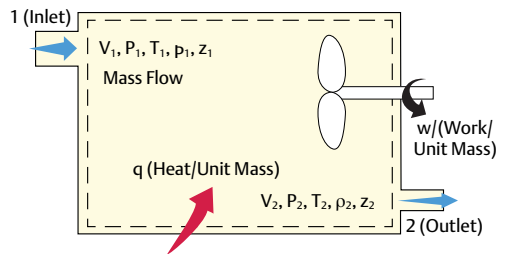
### 3.2.5 Combining the Fluid Energy Forms

The energy forms defined here are in the same units and are combined to give the total energy of a fluid:

$$KE + BE + PE + IE = Total \text{ Energy}$$

The absolute values for each of these forms of energy can be measured, however, it is more meaningful to measure the change in each form of energy as a fluid flows through what is called a system. [Figure 3.1](#) shows a schematic of an energy system. The system could be a pump, a boiler, a heat exchanger, a throttling valve, or for a DP flow meter, the DP primary element.

**Figure 3.1: Energy change for a fluid flow system.**



A system boundary is drawn around the system perimeter, and the change in the energy forms are measured as the difference between the inlet (1) and the outlet (2). There are two more concepts of energy needed when discussing a system:

1. Heat added to a system (+q) or removed from a system (-q). This could be the heat added by a boiler to make steam or heat removed from a fluid using a heat exchanger.
2. Work added to a system (+w) or removed from a system (-w), which is also called shaft work. Work added to a system could be from a pump or a compressor. Work removed from a system could be from a turbine that is converting the pressure of a fluid to mechanical work.

To the system defined by the boundary, we apply the conservation of energy rule:

$$\Delta KE + \Delta BE + \Delta PE + \Delta IE + q + w = 0$$

Where:

$\Delta$  Change in the energy terms from the inlet to the outlet of the system

This equation accounts for all forms of energy change in the fluid. The change in total energy of the outlet minus the inlet fluid is equal to 0, or energy can be neither created or destroyed. Substituting the basic formulas for each of the energy types in this equation gets:

$$\left( \frac{V_1^2}{2g_c} - \frac{V_2^2}{2g_c} \right) + \frac{(z_1 - z_2)g_l}{g_c} + \left( \frac{P_1}{\rho_1} - \frac{P_2}{\rho_2} \right) + c_v(T_1 - T_2) + q + w = 0$$

This is the one-dimensional general form of the fluid energy equation.

### 3.3 Specific Forms of the Fluid Energy Equation

Specific forms of the fluid energy equation are derived from the general form to represent different fluid systems. If no heat is added, and no work is done, the energy equation becomes:

$$\Delta \left( \frac{V^2}{2g_c} + \frac{P}{\rho} + \frac{zg_l}{g_c} \right) + h_l = 0$$

Where:

$h_l$  Replaces the internal energy term and represents energy lost due to friction (i.e., viscous loss) in the system

This form can be used for the flow of real fluids, as the energy loss term accounts for the losses due to fluid viscosity.

The Bernoulli form of this equation is:

$$\Delta \left( \frac{V^2}{2g_c} + \frac{P}{\rho} + \frac{zg_l}{g_c} \right) = 0$$

Since there is no loss term, this form is considered the energy equation for an ideal fluid. This equation also assumes a constant density.

Multiplying the terms in the Bernoulli equation by the fluid density,  $\rho$ , gets the ideal-fluid pressure form where each term is in units of pressure:

$$\Delta \left( \frac{\rho V^2}{2g_c} + P + \frac{\rho z g_l}{g_c} \right) = 0$$

This form is used to derive the DP flow meter equation. If each term in the pressure form of the energy equation is divided by the specific weight of the fluid,  $\gamma = \rho g_l / g_c$ , you get the hydraulic head form of the equation:

$$\Delta \left( \frac{V^2}{2g_l} + \frac{P}{\gamma} + z \right) = 0$$

Where each term is in units of length, or head.

This form is commonly used for water flow systems where water is pumped to, or flows from, reservoirs or sumps.

### 3.4 The Energy Equation for the DP Flow Meter

The DP flow meter is a system with no heat added and no work done. It is derived using horizontal flow, so there is no body energy term, or  $(z_1 - z_2) = 0$ . The theoretical form of these equations means that there are no losses due to friction, or viscous flow. To apply the energy equation, we define the two different types of DP flow meters:

1. Area DP flow meter — the difference in pipe static pressures is primarily due to a change in flowing area.
2. Pitot tube DP flow meter — the stagnation pressure of the fluid is measured.

The equations are very similar, with the major differences in how the real equations are derived.

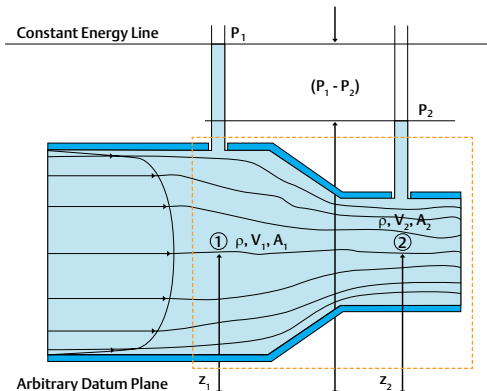
#### 3.4.1 Deriving the Theoretical Area DP Flow Meter Equation

A simple area DP flow meter system with boundary is shown in [Figure 3.2](#).

Starting with the pressure form of the Bernoulli equation for an incompressible fluid with the boundary shown for a horizontal system:

$$\left( \frac{\rho V_2^2}{2g_c} - \frac{\rho V_1^2}{2g_c} \right) = (P_1 - P_2)$$

Figure 3.2: The area meter DP energy system.



If the fluid density is known, and the DP can be measured, there are still two unknown values:  $V_1$  and  $V_2$ . Another equation is needed. This is where the other fundamental physical property is used that states mass is also conserved. In [Chapter 1](#), we introduced the continuity equation:

$$A_1 \times V_1 \times \rho_1 = A_2 \times V_2 \times \rho_2$$

For an incompressible fluid, we solve for  $V_1$  in terms of  $V_2$ :  $V_1 = \frac{A_2}{A_1} V_2$ , substitute into the Bernoulli equation and rearrange terms:

$$V_2^2 \left( 1 - \left( \frac{A_2}{A_1} \right)^2 \right) = \frac{2g_c(P_1 - P_2)}{\rho}$$

or

$$V_2 = \sqrt{\frac{1}{\left( 1 - \left( \frac{A_2}{A_1} \right)^2 \right)}} \sqrt{\frac{2g_c(P_1 - P_2)}{\rho}}$$

The term:

$$\sqrt{\frac{1}{\left( 1 - \left( \frac{A_2}{A_1} \right)^2 \right)}}$$

is called the velocity of approach factor and is abbreviated  $E$ .

For the circular pipe, the area ratio is:

$$\frac{A_2}{A_1} = \left( \frac{d}{D} \right)^2 = \beta^2$$

Where:

- $d$  Diameter of the circular section at the constriction, or throat, of the meter
- $D$  Diameter of the large or upstream section of the area meter
- $\beta$  Ratio of the small to large diameter of an area meter,  $\frac{d}{D}$ , called the beta ratio

Also, from Chapter 1:

$$Q_v = V_2 A_2, \text{ and}$$

$$A_2 = \frac{\pi}{4} d^2$$

So the theoretical, incompressible, volumetric area DP flow meter equation is:

$$Q_v(Theor) = \frac{\pi}{4} d^2 \sqrt{\frac{1}{(1-\beta^4)}} \sqrt{\frac{2g_c(P_1 - P_2)}{\rho}}$$

There is now the flow rate for the area DP flow meter as a function of the fluid density, the differential pressure, and the diameters of the two areas.

To get the mass flow rate, remember that:

$$Q_m = Q_v \times \rho$$

So that:

$$Q_m(Theor) = \rho \left( \frac{\pi}{4} d^2 \sqrt{\frac{1}{(1-\beta^4)}} \sqrt{\frac{2g_c(P_1 - P_2)}{\rho}} \right)$$

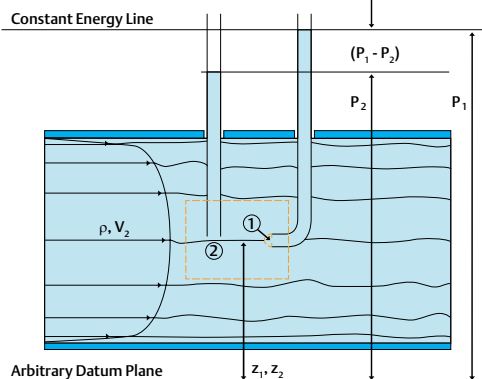
$$Q_m(Theor) = \frac{\pi}{4} d^2 \sqrt{\frac{1}{(1-\beta^4)}} \sqrt{2g_c(P_1 - P_2)\rho}$$

The only difference between the volume and mass flow equations is the location of the fluid density in the equation.

#### 3.4.2 Deriving the Theoretical Pitot Tube DP Flow Meter Equation

Deriving the theoretical DP flow meter equation for pitot tubes and averaging pitot tubes is done in a very similar fashion. The system diagram for a pitot tube with boundary is shown in [Figure 3.3](#).

**Figure 3.3: The pitot tube DP energy system.**



Starting with the same pressure form of the Bernoulli equation for the boundary shown:

$$\left( \frac{V_2^2}{2g_c} - \frac{V_1^2}{2g_c} \right) = \left( \frac{P_1 - P_2}{\rho} \right) = \left( \frac{P_T - P_S}{\rho} \right)$$

It is seen that the value  $V_1=0$ , or that the fluid is brought to rest, without losses (i.e., isentropic process) at the pitot tip with the value of  $P_1$  as the total pressure,  $P_T$ , and the value of  $P_2$  the pipe static pressure,  $P_S$ . The equation is then:

$$\frac{V_2^2}{2g_c} = \left( \frac{P_T - P_S}{\rho} \right)$$

Solving for  $V_2$ :

$$V_2 = \sqrt{\frac{2g_c(P_T - P_S)}{\rho}}$$

Using the same method to obtain the incompressible volumetric flow rate,  $Q_v = V_2 A$ , where:

$$A = \frac{\pi D^2}{4} \text{ for the pipe}$$

So for the pitot tube DP flow meter:

$$Q_v(Theor) = \frac{\pi}{4} D^2 \sqrt{\frac{2g_c(P_T - P_S)}{\rho}}$$

And for the mass flow rate:

$$Q_m(Theor) = \frac{\pi}{4} D^2 \sqrt{2g_c(P_T - P_S)\rho}$$

Notice the similarity in the area and pitot tube DP flow meter equations. Also, while the averaging pitot tube uses this equation, the measured pressures are different than for a single-point pitot tube and the DP is actually  $(P_H - P_L)$ , where:

$P_H$  High pressure, which represents the average stagnation pressure of the velocity along the pipe diameter the averaging pitot tube is installed in

$P_L$  Low pressure, which is the pressure generated at the rear or base of a drag-port averaging pitot tube cylinder and is lower than the pipe static pressure

See [Chapters 7](#) and [9](#) for more information about the averaging pitot tube.

## 3.5 Theoretical and True Fluid Flow Equations

As stated in *Chapter 1*, the ideal fluid Bernoulli equation form is used to derive the DP flow meter equation. Due to the fact that industrial fluids are considered real since they have viscosity, some accounting for the viscous losses is needed in the DP flow meter equations. This is done by defining coefficients for the two types of DP primary elements using the true flow rate.

For the area DP flow meter:

$$C = \frac{Q(\text{True})}{Q(\text{Theor})}, \text{ called the discharge coefficient}$$

For the pitot and averaging pitot tube:

$$K = \frac{Q(\text{True})}{Q(\text{Theor})}, \text{ called the flow coefficient}$$

Where:

$Q(\text{True})$  Flow rate obtained in the flow calibration laboratory or the adjusted flow rate when using the true flow equation

$Q(\text{Theor})$  Flow rate calculated using the theoretical DP flow equations

Due to the viscous losses as the fluid flows through or around a DP primary element, the actual differential pressure is larger than what theory would predict. For this reason, both the discharge and flow coefficient values are less than one. An important difference between the discharge and flow coefficient is that the discharge coefficient represents the increase in DP due to the viscous losses only. The DP increase due to the area change is accounted for in the value of the velocity of approach factor,  $E$ . For the flow coefficient, however, both the area change and the viscous losses are accounted for in one factor.

When these coefficients are added to the theoretical DP flow meter equations, the true flow equations for viscous, incompressible flow are obtained.

For the area DP flow meter:

$$Q_v = CE \frac{\pi}{4} d^2 \sqrt{\frac{2g_c(P_1 - P_2)}{\rho}}$$

For the pitot and averaging pitot tube:

$$Q_v = K \frac{\pi}{4} D^2 \sqrt{\frac{2g_c(P_T - P_S)}{\rho}}$$

Bringing back the original pressure-energy equation for the real fluid flow, which includes the pressure loss:

$$\left( \frac{\rho V_2^2}{2g_c} - \frac{\rho V_1^2}{2g_c} \right) = (P_1 - P_2) - P_L$$

Where:

$P_L$  Pressure loss for the area DP flow meter for a real fluid

Note: The pressure loss is not the only unmeasured energy lost in the system. There is also a loss of internal energy, but it is very small and does not affect the characterization of the DP flow meter.

Solving for  $V_2$  using the true fluid DP flow equation:

$$V_2(\text{True}) = E \sqrt{\frac{2g_c[(P_1 - P_2) - P_L]}{\rho}}$$

Solving for  $V_2$  using the theoretical fluid DP flow equation:

$$V_2(\text{Theor}) = E \sqrt{\frac{2g_c(P_1 - P_2)}{\rho}}$$

Using these equations to solve for C allows us to define the discharge coefficient:

$$C = \frac{Q(\text{True})}{Q(\text{Theor})} = \frac{V_2(\text{True})}{V_2(\text{Theor})} = \sqrt{\frac{[(P_1 - P_2) - P_L]}{(P_1 - P_2)}}$$

or

$$C = \sqrt{1 - \frac{P_L}{(P_1 - P_2)}}$$

The discharge coefficient, C, depends on the ratio of the pressure loss to the theoretical meter DP and will always be less than one. When this ratio is constant over the range of velocities the meter is used for, the discharge coefficient will also be constant.

Because the pitot tube and averaging pitot tube flow coefficient depends on the area change and the viscous losses, it is not as straightforward to derive. See [Chapter 7](#) for a derivation of the flow coefficient, K.

### 3.6 The Practical DP Flow Equations

The previous equations can be used for any chosen area DP flow meter or averaging pitot tube if the values for C and K are known. However, they are limited to a base set of units. The unit of the diameter, DP, density, and the inertial conversion constant as used in the equation must produce the flow rate units. For the true DP flow meter equations, the base units are those used from the energy equations and in U.S. Customary (USC) units (SI units) are:

$Q_v$  Flow rate in  $ft^3/sec$  ( $m^3/sec$ ) at actual or flowing conditions (also known as  $Q_A$ )

$d$  or  $D$  Diameter in  $ft$  ( $m$ )

$g_c$  Inertial force conversion constant,  $lb_m \cdot ft / (lb_f \cdot sec^2)$  ( $kg \cdot m / (N \cdot sec^2)$ )<sup>1)</sup>

$(P_1 - P_2)$  Differential pressure,  $lb_f/ft^2$  ( $N/m^2$  – or *pascal*)

$\rho$  Fluid density,  $lb_m/ft^3$  ( $kg/m^3$ )

Some of these units are not commonly used [e.g., diameter is measured in inches (mm), not feet (m)], and most users want to be able to define the values used in the equations in other unit types. A method is needed that allows for a number of different units for these parameters to be used. The software used to configure DP flow meters is able to do this. The derivation is shown here and can be used to allow a flow calculation for any type of unit, provided there is a conversion for the desired unit to the base units shown. The result gives the practical DP flow meter flow equations.

#### 3.6.1 The Units Conversion Factor, N

From the true DP flow meter equations, there are two constants used:  $\pi/4$  and  $\sqrt{2g_c}$ . If these constants are gathered into a single number called N, the equation for the practical, volumetric incompressible flow equation is:

$$Q_v = NCEd^2 \sqrt{\frac{(P_1 - P_2)}{\rho}}$$

and for the averaging pitot tube DP flow meter is:

$$Q_v = NKD^2 \sqrt{\frac{(P_H - P_L)}{\rho}}$$

Where for both equations in the base units:

$$N_{Base} = \frac{\pi}{4} \sqrt{2(32.174)} = 6.300245$$

for USC units, and

$$N_{Base} = \frac{\pi}{4} \sqrt{2(1)} = 1.110721$$

for SI units

Note: The mass flow equations are similar.

<sup>1</sup> The parameter,  $g_c$ , is left out of many references on flow measurement. In SI units, the value is 1, but the units are needed to make the equation come out. In USC units, the value is 32.174, so it can't be ignored, but it may be mistakenly called the acceleration of gravity. This is not true.

These are the values for  $N$  using the base set of units for the required equation parameters. Other units are derived by using the conversion for the desired units back to the base units in the flow equations. [Table 3.1](#) shows the values of  $N$  for a sample of other USC units. The value for the desired  $N$  is calculated by multiplying or dividing the value of  $N_{Base}$  by each conversion as it appears in the equation:

$$N = N_{Base} \times C_2 \times C_3 \times C_4 / C_1$$

Note: The conversion for flow rate units is on the left side of the flow equation, so it is divided into the value of  $N_{Base}$  to get the desired  $N$  value.

For the example shown in [Table 3.1](#), the value of  $N$  is calculated by:

$$N = 6.300245 \times \left(\frac{1}{12}\right)^2 \times \sqrt{5.192977} \times 1/\sqrt{1}/(1/(60 \times 7.48052)) = 44.7493$$

Where:

6.300245      Value of  $N_{Base}$

$\left(\frac{1}{12}\right)^2$       Conversion from  $\text{in}^2$  to  $\text{ft}^2$

5.192977      Conversion from  $\text{inH}_2\text{O}$  @ 68 °F to  $\text{lb}_f/\text{ft}^2$ , which is exactly  $(62.31572 \text{ lb}_f/\text{ft}^3) / 12 \text{ in}/\text{ft}$

$1/(60 \times 7.48052)$       Conversion from  $\text{gal}/\text{min}$  to  $\text{ft}^3/\text{sec}$

[Table 3.2](#) shows the same process for SI units. It is possible to mix USC and SI units for the same equation (e.g., having  $\text{m}^3/\text{min}$  as a flow rate unit with inches,  $\text{inH}_2\text{O}$ , and  $\text{lb}_m/\text{ft}^3$  for the other units) as long as the conversions are done to the base units for the value of the  $N_{Base}$  used. However, this is not typically done.

### 3.6.2 Standard Volume Flow

Another type of flow rate unit that is still popular is standard volume flow, which is called normal volume flow outside of the U.S. The purpose of a standard volume is to be able to compare volumetric flow rates at different conditions to a standard set of conditions. The density at the standard (i.e., the base) volume is based on

the definition of a standard pressure,  $P_b$ , and standard temperature,  $T_b$  (i.e., base pressure and base temperature). For a gas, the calculation of the density at any condition is done using the equation of state (see [Chapter 2](#)):

$$\rho_i = \frac{P_i M}{z_i R T_i}$$

$\rho_i$       Gas density at condition  $i$

$P_i$       Gas pressure at condition  $i$

$M$       Gas molecular weight

$z_i$       Gas compressibility at condition  $i$

$R$       Universal gas constant

$T_i$       Absolute temperature at condition  $i$

For the standard (base) density, the calculation of the gas density is:

$$\rho_b = \frac{P_b M}{z_b R T_b}$$

And at flowing conditions is:

$$\rho_f = \frac{P_f M}{z_f R T_f}$$

For a liquid, the density at flowing conditions is calculated with an equation using temperature and the density at a reference, or base, density:

$$\rho_f = \rho_b(T)$$

The values used for the base conditions for USC units (SI units) are typically:

$$P_b = 14.6960 \text{ psia} (101.325 \text{ kPa})$$

$$T_b = 59 \text{ °F} (15 \text{ °C})$$

The base conditions used to determine the standard volume flow rate may be different than these values. When a standard volume flow rate is used, it is imperative that the values for the standard base pressure and temperature used to determine the standard volume are defined. Also, at these conditions, the value of  $z_b$  for a gas is very near 1.000, but it depends on the type of gas being measured and the preferences of the weights and measures authority.

### 3 – Theory of DP Flow

**Table 3.1: Example values for the units conversion factor, N, in USC units.**

Volumetric Flow Rate Equation									
Flow Rate Units	Conversion to Base Units – C1	Diameter Units	Conversion to Base Units – C2	DP Units	Conversion to Base Units – C3	Density Units	Conversion to Base Units – C4	Calculation of N	
Desired Unit	Conversion to ft <sup>3</sup> /sec	Desired Unit	(Conversion to ft) <sup>2</sup>	Desired Unit	√(Conversion to lb <sub>m</sub> /ft <sup>2</sup> )	Desired Unit	√(Conversion to lb <sub>m</sub> /ft <sup>3</sup> )	N <sub>BASE</sub> Value	N=N <sub>BASE</sub> × C2 × C3 × C4/C1
gal/min	2.2280E-03	in.	6.94444E-03	inH <sub>2</sub> O	2.27881	lb <sub>m</sub> /ft <sup>3</sup>	1	6.30024	44.7493
gal/sec	0.133681	in.	6.94444E-03	inH <sub>2</sub> O	2.27881	lb <sub>m</sub> /ft <sup>3</sup>	1	6.30024	0.745822
gal/hr	3.7133E-05	in.	6.94444E-03	inH <sub>2</sub> O	2.27881	lb <sub>m</sub> /ft <sup>3</sup>	1	6.30024	2684.96
ft <sup>3</sup> /sec	1	in.	6.94444E-03	inH <sub>2</sub> O	2.27881	lb <sub>m</sub> /ft <sup>3</sup>	1	6.30024	0.0997018
ft <sup>3</sup> /min	0.166667	in.	6.94444E-03	inH <sub>2</sub> O	2.27881	lb <sub>m</sub> /ft <sup>3</sup>	1	6.30024	5.98211
ft <sup>3</sup> /hr	2.7778E-04	in.	6.94444E-03	inH <sub>2</sub> O	2.27881	lb <sub>m</sub> /ft <sup>3</sup>	1	6.30024	358.927

Mass Flow Rate Equation									
Desired Unit	Conversion to lb <sub>m</sub> /sec	Desired Unit	(Conversion to ft) <sup>2</sup>	Desired Unit	√(Conversion to lb <sub>m</sub> /ft <sup>2</sup> )	Desired Unit	√(Conversion to lb <sub>m</sub> /ft <sup>3</sup> )	N <sub>BASE</sub> Value	N=N <sub>BASE</sub> × C2 × C3 × C4/C1
lb <sub>m</sub> /sec	1	in.	6.94444E-03	inH <sub>2</sub> O	2.27881	lb <sub>m</sub> /ft <sup>3</sup>	1	6.30024	0.0997018
lb <sub>m</sub> /min	0.0166667	in.	6.94444E-03	inH <sub>2</sub> O	2.27881	lb <sub>m</sub> /ft <sup>3</sup>	1	6.30024	5.98211
lb <sub>m</sub> /hr	2.778E-04	in.	6.94444E-03	inH <sub>2</sub> O	2.27881	lb <sub>m</sub> /ft <sup>3</sup>	1	6.30024	358.927
lb <sub>m</sub> /day	1.157E-05	in.	6.94444E-03	inH <sub>2</sub> O	2.27881	lb <sub>m</sub> /ft <sup>3</sup>	1	6.30024	8614.24
tons (US)/hr	1.38889E-07	in.	6.94444E-03	inH <sub>2</sub> O	2.27881	lb <sub>m</sub> /ft <sup>3</sup>	1	6.30024	717853
tons (US)/day	5.78704E-09	in.	6.94444E-03	inH <sub>2</sub> O	2.27881	lb <sub>m</sub> /ft <sup>3</sup>	1	6.30024	17228476

For example: for a flow rate in gal/min, d in inches, DP in inH<sub>2</sub>O, and density in lb<sub>m</sub>/ft<sup>3</sup>, N is 44.7493.



**Table 3.2: Example values for the units conversion factor,  $N$ , in SI units.**

Actual Volume Flow Rate Equation									
Flow Rate Units	Conversion to Base Units – C1	Diameter Units	Conversion to Base Units – C2	DP Units	Conversion to Base Units – C3	Density Units	Conversion to Base Units – C4	Calculation of $N$	
Desired Unit	Conversion to m <sup>3</sup> /sec	Desired Unit	(Conversion to m) <sup>2</sup>	Desired Unit	√(Conversion to Pascal)	Desired Unit	1/√(Conversion to kg/m <sup>3</sup> )	$N_{BASE}$ Value	$N=N_{BASE} \times C2 \times C3 \times C4/C1$
m <sup>3</sup> /sec	1	mm	1.00E-06	kPa	31.6228	kg/m <sup>3</sup>	1	1.11072	3.51241E-05
m <sup>3</sup> /sec	1	mm	1.00E-06	millibar	10.00	kg/m <sup>3</sup>	1	1.11072	1.11072E-05
m <sup>3</sup> /min	0.0166667	mm	1.00E-06	kPa	31.6228	kg/m <sup>3</sup>	1	1.11072	2.10744E-03
m <sup>3</sup> /hr	2.7778E-04	mm	1.00E-06	kPa	31.6228	kg/m <sup>3</sup>	1	1.11072	0.126447
l/sec	0.0010	mm	1.00E-06	kPa	31.6228	kg/m <sup>3</sup>	1	1.11072	0.0351241
l/min	1.66667E-05	mm	1.00E-06	kPa	31.6228	kg/m <sup>3</sup>	1	1.11072	2.10744

Mass Flow Rate Equation									
Desired Unit	Conversion to kg/sec	Desired Unit	(Conversion to m) <sup>2</sup>	Desired Unit	√(Conversion to Pascal)	Desired Unit	√(Conversion to kg/m <sup>3</sup> )	$N_{BASE}$ Value	$N=N_{BASE} \times C2 \times C3 \times C4/C1$
kg/sec	1	mm	1.00E-06	kPa	31.6228	kg/m <sup>3</sup>	1	1.11072	3.51241E-05
kg/sec	1	mm	1.00E-06	millibar	10	kg/m <sup>3</sup>	1	1.11072	1.11072E-05
kg/sec	1	mm	1.00E-06	mmH <sub>2</sub> O	3.12874	kg/m <sup>3</sup>	2	1.11072	6.95031E-06
kg/min	0.0166667	mm	1.00E-06	kPa	31.6228	kg/m <sup>3</sup>	1	1.11072	2.10744E-03
kg/hr	2.77778E-04	mm	1.00E-06	kPa	31.6228	kg/m <sup>3</sup>	1	1.11072	0.126447
tons (m)/hr	2.77778E-07	mm	1.00E-06	kPa	31.6228	kg/m <sup>3</sup>	1	1.11072	126.447
tons (m)/day	1.15741E-08	mm	1.00E-06	kPa	31.6228	kg/m <sup>3</sup>	1	1.11072	3034.72

**For example: for a flow rate in l/min,  $d$  in mm, DP in kPa, and density in kg/m<sup>3</sup>,  $N$  is 2.10744.**

The standard volume flow rate is abbreviated  $Q_s$  and is related to the other flow rates by:

$$Q_s \rho_b = Q_m = Q_A \rho_f$$

Where the volumetric flow term is changed from  $Q_v$  to  $Q_A$  to show it is the volume at actual or flowing conditions.

The previous equation shows that mass flow equals mass flow, and from this equation comes the conversions:

$$Q_s = Q_A \frac{\rho_f}{\rho_b}, \text{ and, } Q_A = Q_s \frac{\rho_b}{\rho_f}$$

It is also true that:  $Q_s = \frac{Q_m}{\rho_b}$ , or the standard volume is the mass flow divided by the base gas density, which is a constant.

The standard volumetric DP flow equation is then:

$$Q_s = \frac{NCEd^2}{\rho_b} \sqrt{(P_1 - P_2)\rho_f}$$

Where the same values for the mass flow equations are used for  $N$ . See [Table 3.3](#).

**Table 3.3: Standard volume  $N$  values.**

$N$	$Q_m$ Units	$Q_s$ Units
<b>USC Units</b>		
0.0997018	lb <sub>m</sub> /sec	Std ft <sup>3</sup> /sec (SCFS)
5.982111	lb <sub>m</sub> /min	Std ft <sup>3</sup> /min (SCFM)
358.927	lb <sub>m</sub> /hr	Std ft <sup>3</sup> /hr (SCFH)
9094.96	lb <sub>m</sub> /day	Std ft <sup>3</sup> /day (SCFD)
<b>SI Units</b>		
3.51E-05	kg/sec	Normal m <sup>3</sup> /sec
2.11E-03	kg/min	Normal m <sup>3</sup> /min
0.126447	kg/hr	Normal m <sup>3</sup> /hr
3.03472	kg/day	Normal m <sup>3</sup> /day

### 3.7. Reynolds Number and the Velocity Profile

The concept of the Reynolds number was introduced in [Chapter 1](#). This value is dimensionless as it is a ratio of the inertial to the viscous forces. Viscosity is a measure of the force required to produce a change in velocity between layers of the fluid. Viscosity tends to force the fluid into discrete layers, or lamina, with each succeeding layer from a fixed wall, having a slightly higher velocity. The inertial force propels the fluid down a pipe. The point where these two forces are balanced create an equilibrium. The Reynolds number at these conditions can be used to represent the character of that flow or velocity field. The pipe Reynolds number is defined by:

$$Re_D = \frac{VL\rho}{\mu}$$

Where:

- $V$  Velocity of the fluid in the pipe, which for a real fluid is the average velocity at the measuring section, *ft/sec (m/sec)*
- $L$  Characteristic length, *ft (m)*. This value defines the type of Reynolds number
- $\rho$  Fluid density at the measuring point, *lb<sub>m</sub>/ft<sup>3</sup> (kg/m<sup>3</sup>)*
- $\mu$  Fluid viscosity at the measuring point, *lb<sub>m</sub>/ft · sec (kg/(m · sec))*

The types of Reynolds numbers are calculated by using a different characteristic length. The most common types used in DP flow measurement are:

$Re_D$  Pipe Reynolds number, given by:  
 $Re_D = \frac{VD\rho}{\mu}$ , and used for pipe flow

Where:

$D$  Pipe inside diameter

$Re_d$  Bore Reynolds number, given by:

$$Re_d = \frac{vd\rho}{\mu}, \text{ and used for area DP meters}$$

Where:

$d$  Diameter of the area meter bore or throat

$Re_{rod}$  Rod Reynolds number, given by:

$$Re_{rod} = \frac{Vd_r\rho}{\mu}$$

Where:

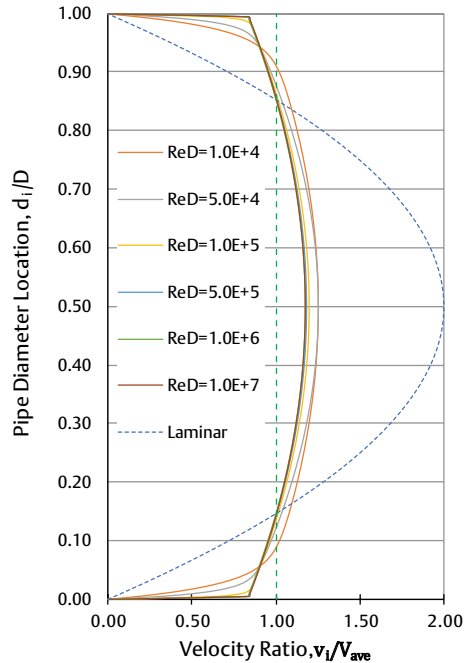
$d_r$  Diameter of the cylinder or rod in a flow stream

This is used to characterize averaging pitot tube applications.

Different fluids that are flowing at the same Reynolds number will have a nearly identical velocity field. This is why this factor is used for configuring flow meters. [Figure 3.4](#) shows the velocity profiles for the different Reynolds number regimes. The horizontal axis represents the location along the diameter at any point,  $d_p$ , divided by the pipe diameter,  $D$ . The vertical axis represents the velocity at any point,  $v_i$  divided by the pipe average velocity,  $V$ . Since the diameter location and the velocity are given as ratios, this could apply for any pipe. The laminar flow regime is where the viscous forces dominate, and the velocity profile is parabolic in shape. The turbulent flow regime, above a Reynolds number of 4000, is where dynamic forces dominate. In this regime, the layers of the viscous flow break apart into small eddies and force the velocity profile into a much flatter shape with the portion very near the wall reverting to the laminar form. Between these two very distinct types of flows is the transition regime, which has elements of both flow types.

The boundaries of this regime are difficult to predict so it is not recommended to measure fluids operating there.

**Figure 3.4: Velocity profiles for laminar and turbulent flow regimes.**



#### 3.7.1 The Velocity Profile

The velocity profile is created due to the viscous nature of real fluids. For flow meters that rely on the fluid velocity to calculate the flow rate, it is important to determine the response of the flow meter to the velocity profile over the range of flow to be measured. For a single-point pitot tube, the device must be moved from the pipe wall to the pipe center so that the profile can be determined and the velocity averaged if the true flow rate is to be calculated. The point on each profile where the average pipe velocity could be measured is shown in [Figure 3.4](#) where the green dashed line crosses the profile. This is where a single-point pitot tube would be positioned to read the flow rate. This location changes with the Reynolds number, however, and it can move significantly for

undeveloped flow fields. This is why an averaging pitot tube is designed to sample the velocity across the pipe diameter.

#### 3.7.2 Kinetic Energy Coefficient

The first energy term for a flowing fluid is kinetic energy. For an ideal fluid, the velocity is the same everywhere in the measuring plane, and the kinetic energy per unit mass is:

$$KE(Ideal) = \frac{\rho v^2}{2g_c}$$

The total kinetic energy assuming the ideal fluid is:

$$KE(Ideal) = \dot{m} \frac{\bar{V}^2}{2g_c} = \rho \bar{v} A \frac{\bar{V}^2}{2g_c} = \frac{\rho A}{2g_c} V^3$$

Where:

- $\bar{V}$  Average real fluid velocity in the pipe
- $\dot{m}$  Mass flow rate, which is  $\rho \bar{v} A$

For a real fluid, the kinetic energy at any point in the measuring plane will be different because the fluid velocity changes across the pipe diameter. The total kinetic energy for a real fluid can be calculated by:

$$KE(Real) = \int (v^2 / 2g_c) d\dot{m}$$

Where:

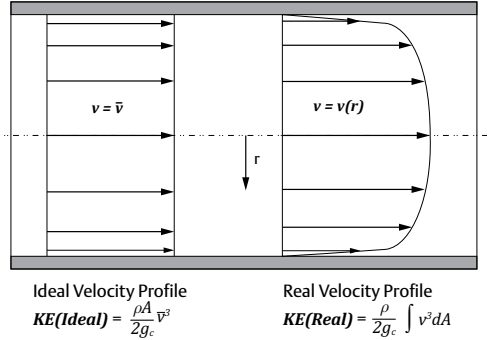
- $d\dot{m}$  Elemental mass flow rate or  $v\rho dA$
- $v$  Incremental velocity at a point on the profile

The real kinetic energy is then:

$$KE(Real) = \frac{\rho}{2g_c} \int v^3 dA$$

Where the incremental velocity,  $v$ , determines the kinetic energy for the incremental area,  $dA$ , and the values summed to determine the total kinetic energy at the measurement plane. [Figure 3.5](#) shows the ideal and real velocity profiles for a pipe flow and the total kinetic energy for each.

**Figure 3.5: Ideal and real pipe velocity profiles and the kinetic energy.**



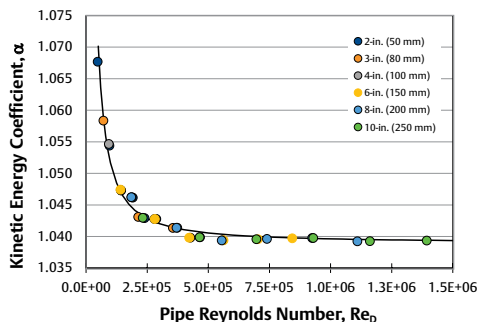
Since the average pipe velocity can be determined from the flow rate, it is always available, where the velocity profile is not as easy to determine. For this reason, the kinetic energy coefficient,  $\alpha$ , is used and is defined as:

$$\alpha(KE) = \frac{\rho \int \frac{v^3}{2g_c} dA}{\rho A \frac{\bar{V}^3}{2g_c}} = \frac{\int v^3 dA}{A \bar{V}^3}$$

The effects of the velocity profile on the kinetic energy can be determined at different Reynolds numbers using typical velocity profile models and applied to the ideal kinetic energy to correct the value using the average velocity.

[Figure 3.6](#) shows the kinetic energy coefficient for Reynolds numbers for typical water velocities in standard pipe sizes. The value quickly approaches a constant value of 1.04 as the Reynolds number increases. This is because in a turbulent Reynolds number flow range, the velocity profile is very consistent in form. In some cases, when using the kinetic energy term in the DP energy equation for a real fluid flow, the kinetic energy coefficient is used to account for the true value. This is done when deriving the averaging pitot tube flow coefficient,  $K$ .

Figure 3.6: Kinetic energy coefficient,  $\alpha$ , for water flow vs. Reynolds number by pipe size.



### 3.7.3 Calculating the Reynolds Number

The Reynolds number uses the same parameters as the flow equations: fluid velocity, pipe diameter, fluid density, and viscosity. However, like the flow equations that are in base units, the Reynolds number requires some units that are not common. For this reason, the equations are rewritten with a conversion constant so that more common units can be used. The fluid velocity may not be known, but the flow rate usually is. Knowing that:

$$Q_A = V \cdot A \text{ for actual volumetric flow}$$

$$Q_m = V \cdot A \cdot \rho_f \text{ for mass flow}$$

$Q_S = V \cdot A \cdot \frac{\rho_f}{\rho_b}$  for standard volume flow, and the pipe Reynolds number equations using the flow rate are:

$$Re_D = \frac{Q_A}{\pi D^2/4} \frac{D\rho}{\mu} = N_R \frac{Q_A \rho_f}{D\mu} \text{ for actual volumetric flow}$$

$$Re_D = \frac{Q_m}{\rho_f \pi D^2/4} \frac{D\rho}{\mu} = N_R \frac{Q_m}{D\mu} \text{ for mass flow}$$

$$Re_D = \frac{\rho_b Q_S}{\rho_f \pi D^2/4} \frac{D\rho_f}{\mu} = N_R \frac{Q_S \rho_b}{D\mu} \text{ for standard volume flow}$$

Where the value for  $N_R$  is determined the same way as it was for the flow equations, with the value of  $N_{R-Base}$  the same for both equations and for both USC and SI units:

$$N_{R-Base} = \frac{4}{\pi} = 1.27324$$

Tables 3.4 and 3.5 show the values of  $N_R$  for USC and SI units using volumetric and mass flow units.

Since the Reynolds number is dimensionless, the calculated values using both USC and SI units are the same.

Note: For standard volume flow, use the same values of  $N_R$  as for the mass flow in the base units for the same time units. See Table 3.6.

#### Example:

An 8-inch diameter pipe,  $D=7.981$  inches (202.717 mm) has a flow rate of 2000 gal/min (7570.82 l/min) of water flow at 68 °F (20 °C), with a density of 62.3157 lb<sub>m</sub>/ft<sup>3</sup> (998.2021 kg/m<sup>3</sup>), and a viscosity of 1.002 cP. Calculate the Reynolds number using both the USC units and SI unit values for  $N_R$ , and show they are the same.

**USC:**  $N_R=50.6592$

$$Re_D = 50.6592 \times 2000 \times 62.3157 / 7.981 / 1.002 = 7.8952 \times 10^5$$

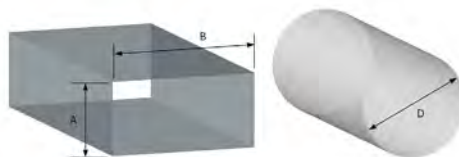
**SI:**  $N_R=21.2207$

$$Re_D = 21.2207 \times 7570.82 \times 998.2021 / 202.717 / 1.002 = 7.8952 \times 10^5$$

### 3.7.4 Non-Circular Pipes or Ducts

For a circular cross-section, the pipe diameter is used in the Reynolds number equation. If the conduit is not circular, there are two methods available to determine the characteristic length. One is to calculate the equivalent diameter for a circle of the same area,  $D_{eq}$ , and the other is to use the hydraulic diameter,  $D_{hyd}$ . Figure 3.7 shows a rectangular and a circular duct.

Figure 3.7: Rectangular duct equivalent dimensions.



An example of these two values for a rectangular duct with dimensions A x B are:

$$D_{eq} = \sqrt{\frac{4 \times Area}{\pi}} = \sqrt{\frac{4AB}{\pi}}$$

$$D_{hyd} = \frac{4 \times Area}{Perimeter} = \frac{4AB}{2(A+B)} = \frac{2AB}{A+B}$$

The hydraulic diameter will give a closer approximation to an equivalent round pipe Reynolds number as the area is proportional to the inertial force and the perimeter to the viscous force.

### 3.8 Developed and Undeveloped Flows

To this point, the theory for the DP flow meter has assumed that the fluid fills the pipe and flows at the same rate over the entire area. From the previous section, however, real fluids have viscosity and cause friction between the fluid and any fixed wall. Since most industrial piping is sized to provide a turbulent flow regime, it appears that the velocity field to be measured is known. However, another concern about fluid velocity fields and measuring the flow rate is that real fluid piping has turns (i.e., elbows), valves, and branches (i.e., tees), pipe size changes (i.e., reductions or expansions) in the piping. These pipe fittings change pipe geometry, which will change the flow field as the fluid travels through

**Table 3.4: Reynolds number,  $N_R$ , values in USC units.**

Volumetric Flow Reynolds Number Equation: $Re_D = N_R \times Q_v \times \rho / (D \times \mu)$									
Flow Rate Units	Conversion to Base Units – C1	Density Units	Conversion to Base Units – C2	Diameter Units	Conversion to Base Units – C3	Viscosity Units	Conversion to Base Units – C4	Calculation of $N_R$	
Desired Unit, $Q_v$	Conversion to ft <sup>3</sup> /sec	Desired Unit, $\rho$	Conversion to lb <sub>m</sub> /ft <sup>3</sup>	Desired Unit, $D$	1/Conversion to ft	Desired Unit, $\mu$	1/Conversion to lb <sub>m</sub> /(ft-sec)	$N_{R-BASE}$ Value	$N_R = N_{BASE} \times C1 \times C2 \times C3 \times C4$
gal/sec	1.3368E-01	lb <sub>m</sub> /ft <sup>3</sup>	1	in.	12.00	cP	1488.16	1.27324	3039.549
gal/min	2.2280E-03	lb <sub>m</sub> /ft <sup>3</sup>	1	in.	12.00	cP	1488.16	1.27324	50.6592
gal/hr	3.7133E-05	lb <sub>m</sub> /ft <sup>3</sup>	1	in.	12.00	cP	1488.16	1.27324	0.844319
ft <sup>3</sup> /sec	1	lb <sub>m</sub> /ft <sup>3</sup>	1	in.	12.00	cP	1488.16	1.27324	22737.4
ft <sup>3</sup> /min	0.0166667	lb <sub>m</sub> /ft <sup>3</sup>	1	in.	12.00	cP	1488.16	1.27324	378.957
ft <sup>3</sup> /hr	2.7778E-04	lb <sub>m</sub> /ft <sup>3</sup>	1	in.	12.00	cP	1488.16	1.27324	6.31595

Mass Flow Reynolds Number Equation: $Re_D = N_R \times Q_m / (D \times \mu)$									
Desired Unit, $Q_v$	Conversion to lb <sub>m</sub> /sec	Desired Unit, $\rho$	Conversion to lb <sub>m</sub> /ft <sup>3</sup>	Desired Unit, $D$	1/Conversion to ft	Desired Unit, $\mu$	1/Conversion to lb <sub>m</sub> /(ft-sec)	$N_{R-BASE}$ Value	$N_R = N_{BASE} \times C1 \times C3 \times C4$
lb <sub>m</sub> /sec	1	–	–	in.	12.00	cP	1488.16	1.27324	22737.4
lb <sub>m</sub> /min	0.0166667	–	–	in.	12.00	cP	1488.16	1.27324	378.957
lb <sub>m</sub> /hr	2.778E-04	–	–	in.	12.00	cP	1488.16	1.27324	6.31595
lb <sub>m</sub> /day	1.157E-05	–	–	in.	12.00	cP	1488.16	1.27324	0.263164
tons (US)/hr	1.38889E-07	–	–	in.	12.00	cP	1488.16	1.27324	3.15797E-03
tons (US)/day	5.78704E-09	–	–	in.	12.00	cP	1488.16	1.27324	1.31582E-04

**Table 3.5: Reynolds number,  $N_R$ , values in SI units.**

Volumetric Flow Reynolds Number Equation: $Re_D = N_R \times Q_v \times \rho / (D \times \mu)$									
Flow Rate Units	Conversion to Base Units – C1	Density Units	Conversion to Base Units – C2	Diameter Units	Conversion to Base Units – C3	Viscosity Units	Conversion to Base Units – C4	Calculation of $N_R$	
Desired Unit, $Q_v$	Conversion to m <sup>3</sup> /sec	Desired Unit, $\rho$	Conversion to lb <sub>m</sub> /ft <sup>3</sup>	Desired Unit, $D$	1/Conversion to meters	Desired Unit, $\mu$	1/Conversion to kg/(m-sec)	$N_{R-BASE}$ Value	$N_R = N_{R-BASE} \times C1 \times C2 \times C3 \times C4$
m <sup>3</sup> /sec	1	kg/m <sup>3</sup>	1	mm	1000	cP	1000	1.27324	1273240
m <sup>3</sup> /min	0.016667	kg/m <sup>3</sup>	1	mm	1000	cP	1000	1.27324	21220.7
m <sup>3</sup> /hr	0.00027778	kg/m <sup>3</sup>	1	mm	1000	cP	1000	1.27324	353.678
l/sec	1.000E-03	kg/m <sup>3</sup>	1	mm	1000	cP	1000	1.27324	1273.24
l/min	1.6667E-05	kg/m <sup>3</sup>	1	mm	1000	cP	1000	1.27324	21.2207
l/hr	2.7778E-07	kg/m <sup>3</sup>	2	mm	1000	cP	1000	1.27324	0.707355

Mass Flow Reynolds Number Equation: $Re_D = N_R \times Q_m / (D \times \mu)$									
Desired Unit	Conversion to kg/sec	Desired Unit, $\rho$	Conversion to lb <sub>m</sub> /ft <sup>3</sup>	Desired Unit, $D$	1/Conversion to ft	Desired Unit, $\mu$	1/Conversion to kg/(m-sec)	$N_{R-BASE}$ Value	$N_R = N_{R-BASE} \times C1 \times C3 \times C4$
g/sec	0.001	–	–	mm	1000	cP	1000	1.27324	1273.24
kg/sec	1	–	–	mm	1000	cP	1000	1.27324	1273240
kg/min	0.0166667	–	–	mm	1000	cP	1000	1.27324	21220.7
kg/hr	2.778E-04	–	–	mm	1000	cP	1000	1.27324	353.678
tons (m)/hr	2.778E-07	–	–	mm	1000	cP	1000	1.27324	0.353678
tons (m)/day	1.15741E-08	–	–	mm	1000	cP	1000	1.27324	1.47366E-02

**Table 3.6: Standard volume  $N_R$  values.**

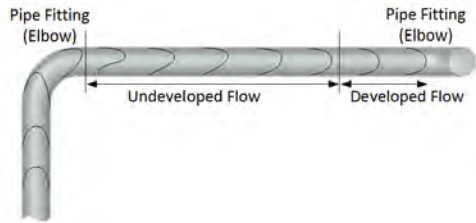
$N$	$Q_m$ Units	$Q_s$ Units
<b>USC Units</b>		
22737.4	lb <sub>m</sub> /sec	Std ft <sup>3</sup> /sec (SCFS)
378.957	lb <sub>m</sub> /min	Std ft <sup>3</sup> /min (SCFM)
6.31595	lb <sub>m</sub> /hr	Std ft <sup>3</sup> /hr (SCFH)
0.263164	lb <sub>m</sub> /day	Std ft <sup>3</sup> /day (SCFD)
<b>SI Units</b>		
1.2732E+06	kg/sec	Normal m <sup>3</sup> /sec
2.1221E+04	kg/min	Normal m <sup>3</sup> /min
353.678	kg/hr	Normal m <sup>3</sup> /hr
8488.26	kg/day	Normal m <sup>3</sup> /day

them. Measuring the fluid flow is usually done in a straight section of pipe. This straight section begins and ends at a pipe fitting. The fluid flow field that enters the straight piping section will be unique. Ideally, for flow meters that respond to the fluid velocity, the flow field that encounters a flow meter should be predictable and defined. To classify this type of flow field, the term developed flow is used. Developed flow will not change or develop further as the fluid travels down a straight pipe section. The opposite is also true. An undeveloped flow field continues to develop or change as it travels down a straight pipe section. *Figure 3.8* shows the change in a flow field as it progresses after a disturbance. At the point where there is no further development, the undeveloped flow field becomes a developed one. The definition of a developed flow includes the following characteristics:

1. The velocity field is axially symmetric, or the velocity profile at any plane through the pipe axis is the same.
2. The velocity field is irrotational, or there is no radial component to the velocity and it is parallel everywhere to the pipe axis.

Fluids at different Reynolds numbers have been measured after very long (e.g., more than 50 pipe diameters) sections of pipe. These profiles also define the developed flow in a pipe. In characterizing developed flow for a specific type of flow meter, the response of the meter is typically used to define whether a flow field is developed or undeveloped. At the point where the flow field does not change the meter output for the same flow rate and fluid conditions within the specified performance tolerance, the flow is considered developed, and the specified length of the pipe sufficient for the given meter. This is the source of the straight pipe charts used to determine the length of straight pipe needed for a flow meter based on the type of upstream fitting.

**Figure 3.8: Undeveloped and developed flow.**



## 3.9 Compressible Flow

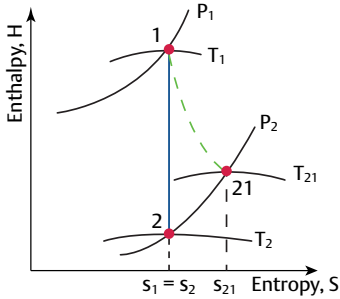
The DP flow meter equations developed to this point have used the Bernoulli equation form, which assumes the fluid density does not change. For gases, the density will change as it travels through or around the DP primary device. Since density is part of the energy balance, this change must be accounted for if accurate results for the DP flow meter measuring a gas are needed. The DP flow equation form that adjusts for this change in density is called the compressible flow form.

### 3.9.1 Isentropic Expansion Factor

Compressible flow is the result of the expansion of a gas from a higher to a lower pressure after it flows through a constriction. The lower pressure at the downstream pressure tap creates a lower density, so the density can no longer be considered constant. A DP flow meter primary element represents a constriction for the gas. For an ideal gas, the expansion can be graphed on an entropy/enthalpy chart. *Figure 3.9* shows an ideal, isentropic gas expansion from a pressure  $P_1$  to a pressure  $P_2$  as the line from point 1 to point 2. Entropy,  $S$ , does not change, so there are no losses. An expansion for an actual process where there are losses is shown as the line from point 1 to point 21. Contoured style DP flow meters, such as Venturi tubes and some flow nozzles, have low pressure tap losses, and the gas expansion can be predicted. Higher loss DP meters, such as the orifice plate, require a custom curve fit.



**Figure 3.9: Expansion of a gas.**



1-2 Isentropic Process  
1-21 Actual Process

The area meter flow equation for compressible flow is a modified version of the incompressible equation:

$$V_2 = \sqrt{\frac{2g_c \left( \frac{p_1 - p_2}{\rho_1 \rho_2} \right)}{1 - A_2^2 \rho_2^2 / A_1^2 \rho_1^2}}$$

Where the values for the gas density at pressure tap points 1 and 2 are defined as  $\rho_1$  and  $\rho_2$ . As explained in Chapter 2 for an isentropic process, the gas pressures and densities are related by:  $\left( \frac{p_2}{p_1} \right)^{1/k} = \left( \frac{\rho_2}{\rho_1} \right)$ , or:

$$\rho_2 = \rho_1 \left( \frac{p_2}{p_1} \right)^{1/k}$$

Where:

$k$  Gas isentropic ratio

This value is substituted into the above equation to eliminate  $\rho_2$ :

$$\left( 1 - A_2^2 \rho_2^2 / A_1^2 \rho_1^2 \right) = \left( 1 - \beta^4 \left( \frac{p_2}{p_1} \right)^{2/k} \right) \text{ and}$$

$$\left( \frac{p_1}{\rho_1} - \frac{p_2}{\rho_2} \right) = \frac{p_1}{\rho_1} - \frac{p_2}{\rho_1 \left( \frac{p_2}{p_1} \right)^{1/k}}$$

If these expressions are put back into the area meter equation for  $V_2$ :

$$V_2 = \sqrt{\frac{2g_c p_1 (1 - \beta^4) \left( \frac{k}{k-1} \right) \left( \frac{p_2}{p_1} \right)^{2/k} \left( 1 - \left( \frac{p_2}{p_1} \right)^{(k-1/k)} \right)}{\rho_1 \left( 1 - \left( \frac{p_2}{p_1} \right) \right) \left( 1 - \beta^4 \left( \frac{p_2}{p_1} \right)^{2/k} \right)}}$$

$$V_2 = Y_1 \epsilon \sqrt{\frac{2g_c DP}{\rho_1}}$$

Where:

$Y_1, \epsilon$  Gas expansion factor (expansibility) for the isentropic process:

$$\sqrt{\frac{\left( \frac{k}{k-1} \right) (1 - \beta^4) \left( \frac{p_2}{p_1} \right)^{2/k} \left( 1 - \left( \frac{p_2}{p_1} \right)^{(k-1/k)} \right)}{\left( 1 - \left( \frac{p_2}{p_1} \right) \right) \left( 1 - \beta^4 \left( \frac{p_2}{p_1} \right)^{2/k} \right)}}$$

$\beta$  Diameter ratio,  $\frac{d}{D}$

$\rho_1$  Gas density at the upstream tap

The practical flow equations for the general, compressible form for liquids or gases using the isentropic expansion for the area meter are obtained by adding  $Y_1$ :

$$Q_A = NCY_1 E d^2 \sqrt{\frac{DP}{\rho}} \text{ for actual volume flow}$$

$$Q_m = NCY_1 E d^2 \sqrt{(DP)\rho} \text{ for mass flow}$$

$$Q_S = \frac{NCY_1 E d^2}{\rho_b} \sqrt{(DP)\rho} \text{ for standard volume flow}$$

Where for the liquid flow equations,  $Y_1=1$ . This form for the calculation of the expansion factor is commonly used for Venturi tubes and some flow nozzles where the low pressure is measured at the nozzle throat.

#### 3.9.2 Non-Isentropic Expansion Factor

For orifice plates and some of the other area meters, the gas expansion through the meter is more abrupt, so it is not considered isentropic. The value of the gas expansion factor (i.e., expansibility) must be obtained by testing and data fitting the results to obtain a method for predicting the value. To obtain the actual values

of the expansion factor, the same flow meter is calibrated on liquid and gas flows, and the value of the expansion factor calculated by:

$$Y = \frac{C(\text{Gas})}{C(\text{Liquid})}$$

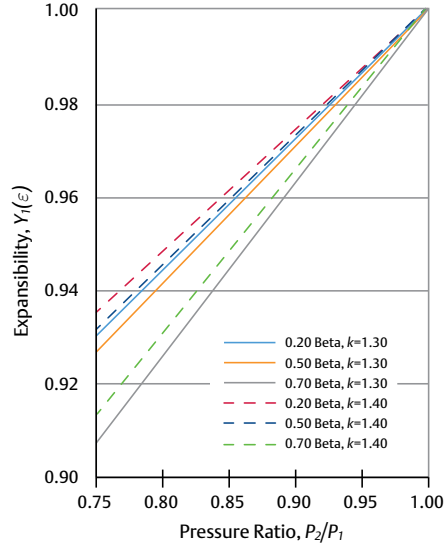
The expansion factor is always less than or equal to 1, and it is proportional to the values of  $p_2/p_1$ ,  $k$ , and the constriction or  $\beta$  (i.e., blockage for an averaging pitot tube). The data for  $Y$  is plotted as a function of  $(P_2/P_1)$ . The plots create lines that start at a value of 1 for  $Y$  and slope downward as the pressure ratio decreases. The slope increases with increasing values of  $\beta$ . [Figure 3.10](#) shows plots for  $Y_1$  vs.  $P_2/P_1$  for the concentric orifice plate with various values of  $\beta$  and two values of the isentropic ratio,  $k$ , of 1.3 and 1.4. These values represent most of the gases metered for industrial flow measurement. The actual values of  $k$  for several gases are shown in [Table 3.7](#).

**Table 3.7: Isentropic ratio,  $k$ , for various gases.**

Gas	$k$	Gas	$k$
Air	1.40	Methane	1.31
Ammonia	1.29	Neon	1.64
Argon	1.67	Nitric Oxide	1.40
Carbon Dioxide	1.28	Nitrogen	1.40
Carbon Monoxide	1.41	Nitrous Oxide	1.26
Chlorine	1.36	Oxygen	1.40
Ethane	1.19	Propane	1.33
Helium	1.66	Propylene	1.14
Hydrogen	1.40	Steam	1.30
Hydrogen Sulfide	1.32	Sulfur Dioxide	1.25

The lines on the graph in [Figure 3.10](#) represent data collected during orifice plate calibrations for gases, which have been fitted to an equation.

**Figure 3.10: Expansion factor (expansibility) for concentric orifice plate for various  $\beta$  and two values of  $k$ .**



This equation approximates the expansion factor by knowing the pressure ratio, diameter ratio, and the isentropic expansion ratio,  $k$ :

$$Y_1(\epsilon) = 1 - (0.351 + 0.256\beta^4 + 0.93\beta^8) \left[ 1 - \left( \frac{P_2}{P_1} \right)^{1/k} \right]$$

While the value  $(P_2/P_1)$  is not easily measured, it can be equated to an expression using the DP and the upstream pressure:

$$\left( \frac{P_2}{P_1} \right) = \frac{P_1 - (P_1 - P_2)}{P_1} = 1 - \frac{\Delta P}{P_1}$$

Where:

- $\Delta P$  Measured differential pressure for the orifice plate (in the same units as  $P_1$ )
- $P_1$  Pressure at the upstream tap

The expansibility will be different for the different types of area meters, but the method for calculating the factor will be very similar as for an orifice plate. The limitations for use of this equation for concentric orifice plate expansibility are the same as for the discharge coefficient, and they are shown in [Table 3.8](#). In addition, there is a

lower limit placed for calculating the value for  $Y$  ( $\varepsilon$ ) based on the data available. For the equation shown, the minimum value for  $P_2/P_1$  is 0.75. It is rare that an application would operate at expansion values below this minimum. Since the expansibility depends on the differential pressure, and the differential pressure depends on the expansibility, an iteration of the flow equation is needed when sizing a DP meter for gas flow.

**Table 3.8: Application limits for the concentric, sharp-edged orifice plate expansibility equation.<sup>1</sup>**

<b>For All Taps</b>
$d \text{ (bore)} \geq 12.5 \text{ mm (0.50 in)}$ $50 \text{ mm (2 in)} \leq D \text{ (pipe)} \leq 1000 \text{ mm (39.4 in)}$ $0.10 \leq \beta \leq 0.75$
<b>For Corner and D, D/2 Taps</b>
$Re_d \geq 5000 \text{ for } 0.10 \leq \beta \leq 0.56$ $Re_d \geq 16000\beta^2 \text{ for } \beta > 0.56$
<b>For Flange Taps</b>
$Re_d \geq 5000 \text{ and } Re_d \geq 170\beta^2 D$

<sup>1</sup> Adapted from ISO 5167-2:2003.

The uncertainty for calculating the expansibility factor depends on the quality of the data collected and the number of sample points. The uncertainty for the equation shown above, given all contributing values are perfectly known, is given as:

$$U(95)\% = 3.5 \frac{\Delta P}{kP_1}$$

Where:

$\Delta P$  Differential pressure for the orifice

$k$  Gas isentropic ratio

$P_1$  Upstream pressure (in the same units as the differential pressure)

The uncertainty of the calculated value increases as the DP increases for the same upstream gas pressure.

### 3.9.3 The Expansion Factor for the Averaging Pitot Tube

For the drag port averaging pitot tube (i.e., low pressure measured at the rear of the averaging pitot tube, or cylinder), the expansion of a gas as it flows around the cylinder is considered non-isentropic, so the expansibility is determined using data and curve-fit just as it is for the concentric orifice plate. To avoid confusion, the symbol for the averaging pitot tube expansion factor is given as  $Y_A$ . Because the averaging pitot tube provides a much smaller constriction to the fluid flow, the plot of the expansibility to the pressure ratio has a much more gradual slope compared to the orifice plate. For the Rosemount™ 485 Annubar™ Averaging Pitot Tube, the expansion factor is given as:

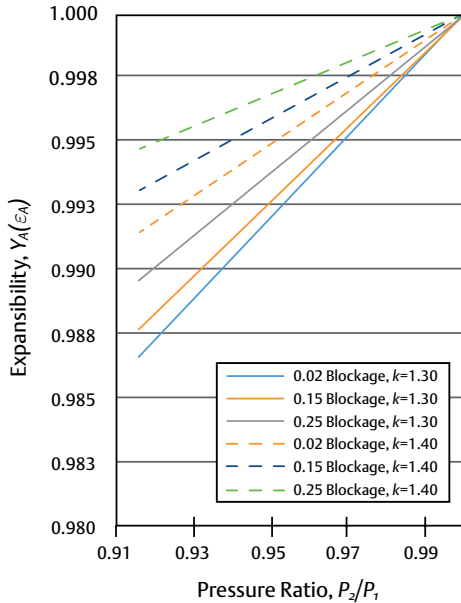
$$Y_A = 1 - (0.31424(1 - B)^2 - 0.09484) \frac{\Delta P}{kP_1}$$

Where:

$B$  Blockage of the averaging pitot tube in the pipe, which is the cylinder projected area divided by the pipe area

*Figure 3.11* shows the results of the equation plotted in a similar fashion to the concentric orifice plate.

**Figure 3.11: Expansibility factor (expansibility) for a Rosemount Annubar Averaging Pitot Tube, various blockage values, and two values of  $k$ .**



### 3.10 Applicable Flow Meter Standards

There are some published standards for flow meters:

1. ISO 5167: Measurement of fluid flow by means of pressure differential devices inserted in a circular-cross section conduits running full – Part 2: Orifice plates, Part 3: Nozzles and Venturi nozzles, and Part 4: Venturi tubes
2. ASME MFC-3M: Measurement of Fluid Flow in Pipes Using Orifice, Nozzle, and Venturi
3. ASME MFC-14M: Measurement of Fluid Flow Using Small Bore Precision Orifice Meters

### 3.11 Additional Information

For more information, refer to the following source:

Miller, Richard W. *Flow Measurement Engineering Handbook* (3rd ed.). McGraw-Hill, 1996.



# 4

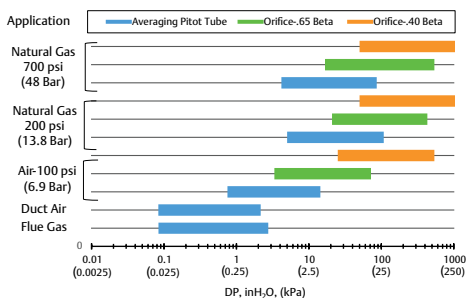
## Gas Applications

	<b>Topic</b>	<b>Page</b>
4.1	Introduction	62
4.2	Common Applications	62
4.3	Special Applications	71
4.4	Gas Density	73
4.5	Issues of Gas Composition	74
4.6	Applicable Flow Meter Standards	75
4.7	Additional Information	77

## 4.1 Introduction

In many industries, the measurement of gas flow is an important parameter and is used for economic, operational control, and safety reasons. Most industrial-grade gases are in a refined or pure form and the properties easily determined, which make the measurement of flow using differential pressure (DP) flow meters a straight-forward task. Gas properties are affected by the temperature and pressure in the piping, and it is important to understand the application before specifying a flow meter. The need to update the calculation of the gas density if the pressure and/or temperature changes depends on the magnitude of the change over the range of measurement and the desired accuracy of the measurement. Since the gas density is under the square root in the calculation of flow rate for a DP flow meter, the effects of the density on the calculated flow is one-half the change in density. For many applications, the compensation of pressure and/or temperature may not be needed. For higher accuracy requirements, compensated flow transmitters or computers will measure the DP, pressure, and temperature, and calculate the density and viscosity of many menu-selectable gases in real time. This calculation is done several times a second and is used to provide the corrected gas flow rate. [Figure 4.1](#) shows recommended DP flow products and application flow ranges vs. the value of DP generated for gas flows.

**Figure 4.1: DP primary elements for gas applications.**



## 4.2 Common Applications

### 4.2.1 Natural Gas

#### Primary Function of Application

The flow measurement of natural gas to a process is a common application for DP flow meters and it is used to determine the cost of a process and/or the heat input to a process based on combustion of the gas. Energy for heat in chemical processes, dryers for paper processing, and feedstock for the manufacturing of chemicals are some of the many applications for measuring the flow of natural gas. The monitoring of gas distribution systems may also use flow measurement to warn of an upset condition, which may indicate a piping component failure.

Natural gas is a combination of elemental gas components. The combination of these components varies based on the location of the wells that produce the gas. If the need for higher accuracy is required, the makeup of components in the gas can be determined using gas chromatographs, and these properties are used to calculate the density and viscosity of the gas. In many cases, the specific gravity of natural gas is updated at the measurement facility daily. In addition to the density and viscosity, the heat content based on stoichiometric combustion can also be determined and the flow of energy to the process computed. This is typically an option for many flow computers including Rosemount™ MultiVariable™ flow transmitters.

Since natural gas is a relatively expensive commodity, flow meters have been developed specifically for the selling and buying of natural gas. See [Figures 4.2, 4.3, and 4.4](#) for examples of natural gas processes and pipelines. To simplify this exchange, standards have been written for the use of flow meters for this purpose. Referred to as custody transfer, this application provides a basis for both the buyer and the seller to install an agreed-upon flow meter system. The first commonly accepted standard was written by AGA in the early 1930s using the concentric

orifice plate. An updated AGA Report No. 3 was issued in 1955, which specifies all aspects of the orifice meter run including the design of the orifice plate, the location of the differential pressure taps, and the dimensions of the piping. Other standards for flow measurement were developed for specific meter types, such as orifice plates, turbine meters, ultrasonic meters, etc. The standards from ASME, MFC-3, and ISO 5167-2 for orifice plates duplicated much of the information in AGA Report No. 3. To provide an uncertainty in the calculation of the flow rate, a large quantity of data was collected on the orifice plate at that time, and it provided the basis for the calculation of the discharge coefficient. This data provided the seed for a very large application base of flow meters using the orifice plate for natural gas and many other fluids.

**Figure 4.2: A natural gas metering station.**



**Figure 4.3: A standard orifice plate used in a natural gas application.**



**Figure 4.4: A Rosemount Compact Annubar™ Flow Meter installed in a natural gas line at a pulp and paper mill.**



### *Application Characteristics and Challenges*

- Natural gas is flammable and is conveyed under pressure. Local standards for piping and the proper maintenance of systems must be taken into consideration when designing flow meter equipment.
- The required flow measurement uncertainty for the given application needs to be stated at the time that the system is specified. In addition, the range of operating conditions for the given process is needed to determine the proper system configuration. The need for pressure and temperature compensation, and the make up of gas components, are used to configure the measuring system.
- The stated performance is ensured only if the systems are properly maintained. Proper installation will prevent condensing liquids in the gas from compromising the DP signal. The primary element condition should be checked once a year or more often, if needed, for wear and material buildup.

### *Suitable Technologies*

Rosemount Technology	Installation Guidelines
Traditional or Conditioning Orifice	10.4.2 - 10.4.4, 10.5.3, 10.5.4, 10.7.3
Annubar Averaging Pitot Tube	10.4.1, 10.5.2, 10.7.2
MultiVariable Transmitter	8.10, 10.3.3, 10.7.4

### 4.2.2 Emissions Measurement

#### Primary Function of Application

Emissions measurement, particularly greenhouse gases, has long been important to environmental authorities at the state and federal level for power generation, petrochemical, and other industrial facilities. These measurement requirements began in large part with legislation in the 1980s and 1990s when the Clean Air Act was created in the U.S. Subsequent revisions and protocols have followed, resulting in more industrial processes that require monitoring as well as tightened accuracy requirements. Averaging pitot tubes with differential pressure technologies offer a commonly accepted and well-known means of emissions measurement when engineered for the individual application.

The Stack Annubar Flow Meter is designed to be installed in emissions stacks to measure emission flows. It has hoist rings for easy lifting and purge ports for online purging to keep the interior clean, which ensures long-term operation. Each installation is unique so each unit is built to specification. See [Figure 4.5](#).

**Figure 4.5:** The Stack Annubar Flow Meter design provides a reliable measurement in a variety of difficult emissions applications.



#### Application Characteristics and Challenges

- Large stack diameters or unconventional ductwork configurations
- High temperatures
- Particulates in the flow stream
- Special alloys may be required due to potential corrosion
- Limited access for installation and maintenance
- Measuring low flow rates
- Meeting regular calibration requirements

#### Suitable technologies

Rosemount Technology	Installation Guidelines
Annubar Averaging Pitot Tube	<a href="#">10.4.1</a> , <a href="#">10.5.2</a> , <a href="#">10.7.2</a>
Traditional or Conditioning Orifice	<a href="#">10.4.2 - 10.4.4</a> , <a href="#">10.5.3</a> , <a href="#">10.5.4</a> , <a href="#">10.7.3</a>
Stack Annubar Flow Meter	<a href="#">10.8.3</a>
MultiVariable Transmitter	<a href="#">8.10</a> , <a href="#">10.3.3</a> , <a href="#">10.7.4</a>

### 4.2.3 Flare Gas

#### Primary Function of Application

Flare stacks are necessary in industries that produce excess gas from the extraction or processing of hydrocarbons. See [Figure 4.6](#). Flaring provides a means of safely disposing of waste gases via combustion through the top of a stack equipped with a burner and igniter. It is important to measure the flow of flare gas for both operational and environmental compliance.

Flow measurement selection depends on the flow conditions, which may include a very wide range of flow rates, pressures, and temperatures. In normal conditions, the flow rates are generally low, but they can be considerably higher in upset conditions. For normal conditions, ultrasonic flow meters are commonly used and perform well at low flow rates. Averaging pitot tube technology can also be considered depending



on flow conditions and whether sufficient differential pressure is generated. The benefits of an averaging pitot tube solution are the ability to remove the sensor for inspection and, when paired with a multivariable transmitter, to perform a compensated mass flow measurement.

**Figure 4.6: A refinery or petrochemical plant flare.**



### Application Characteristics and Challenges

- Normal flow rates can be very low, creating low DP signals. This may require that DP flow transmitters be trimmed regularly. Flow rates that are below the readable range of DP devices may require alternate technologies.
- The wide range of changing conditions may require pressure and temperature compensation. Changing gas composition may also require updating the flow meter configuration depending on the performance requirements for the measurement.
- It is also necessary to configure the flow meter to respond to flow rate changes as quickly as possible. Dampening features on the transmitter should be configured to allow the quickest response.
- If orifice plates are specified, the resulting pressure loss should be calculated to ensure the maximum flow rates can be accommodated.

### Suitable Technologies

Rosemount Technology	Installation Guidelines
Annubar Averaging Pitot Tube	10.4.1, 10.5.2, 10.7.2
Traditional or Conditioning Orifice	10.4.2 - 10.4.4, 10.5.3, 10.5.4, 10.7.3
MultiVariable Transmitter	8.10, 10.3.3, 10.7.4

## 4.2.4 Duct and Blower Applications

### Primary Function of Application

Many industrial processes use air as a primary component in chemical reactions or for cooling or forced evaporation. The conveying of air at low pressures is done using thin-walled ducting and air blowers to move air through a processing system. See [Figure 4.7](#). For the last 30 years, emission requirements have been added, and energy costs have risen for power, refining, and chemical plants. To comply with monitoring requirements and improve process controls, plant process engineers have had to consider measuring flow in air duct systems where it wasn't originally designed. Many applications include ducts that are irregularly shaped or have transitions between hard-mounted components such as fans, process vessels, or boilers. These ducts, whether round or rectangular, often consist of multiple or mitered elbows, reductions, expansions, dampers, or variations in cross-sectional areas. Other potential considerations may include additional duct inlets, internal structural supports, manways, expansion joints, or limited installation or service access. Duct flows operate at near atmospheric pressure and moderate velocities. For this reason, the flow rate signals generated are low. This may limit the measurable range of operation.

The averaging pitot tube is well suited to be customized for this type of duct configuration. Applications of this nature may require specific averaging pitot tube mounting locations or multiple units depending on the upstream and downstream duct configuration. To assess whether the designated metering location is usable and optimal, a preliminary flow test may be

required. Mounting and access considerations can also be assessed at that time.

Depending on the nature of the flow field at the measurement point and the required performance, an in-situ calibration may be needed. This is typically accomplished by performing a pitot traverse at one or more flow rates or power plant load values. This procedure determines the true flow rate at the location of the given flow meter system, which will be used in the calibration after installation. The process for doing a pitot traverse is detailed in [Chapter 10](#).

**Figure 4.7:** A boiler forced-draft fan for combustion air flow.



### Application Characteristics and Challenges

- Duct flow applications are challenging due to the size of the ducts, flow disturbances, and access for installation.
- Finding a location to install a flow measurement point may require a preliminary flow field assessment.
- Performance needs may require in-situ calibration using the pitot traverse method.

- Due to low differential pressure signals, the DP transmitter zero trim should be checked as part of regular maintenance.
- Lightweight primaries are preferred for installation in thin-walled ducts.

### Suitable Technologies

Rosemount Technology	Installation Guidelines
Annubar Averaging Pitot Tube	10.4.1, 10.5.2, 10.7.2
MultiVariable Transmitter	8.10, 10.3.3, 10.7.4

#### 4.2.4.1 Combustion Air Flow

##### Primary Function of Application

Optimizing energy usage involves controlling the air input to a burner of a boiler or heating unit. Many combustion flow meter systems do this by installing a flow meter and using damper controls to adjust air flow to the burner. See [Figure 4.8](#). Some applications may include large and irregular ducting (see [Section 4.2.4](#)) and may require in-situ calibration. The location of the flow measurement device should be chosen to minimize flow disturbances. In-situ calibration at multiple loads or burner output values may be needed to ensure proper burner operation. The process for doing a pitot traverse is detailed in [Chapter 10](#).

**Figure 4.8:** A combined cycle power plant with a large combustion air intake.



### Application Characteristics and Challenges

- Combustion air duct flow applications are challenging due to the size of the ducts, flow disturbances, and access for installation.
- Finding a location to put in a flow measurement point may require a preliminary flow field assessment.
- Performance needs may require in-situ calibration using the pitot traverse method.
- Contaminants in the air may cause plugging or coating of instrumentation.

### Suitable Technologies

Rosemount Technology	Installation Guidelines
Annubar Averaging Pitot Tube	10.4.1, 10.5.2, 10.7.2
MultiVariable Transmitter	8.10, 10.3.3, 10.7.4

#### 4.2.4.2 Heating Ventilation and Air Conditioning (HVAC)

##### Primary Function of Application

HVAC systems provide heating and cooling in commercial applications. See [Figure 4.9](#). The complexity and size of ducting systems in large buildings may require the contractor to balance heating and cooling system air flow to all portions of the building. This is most easily accomplished by installing flow meters at strategic locations in the ducting systems. The absolute value of the flow is usually not needed; a comparison of flow outputs at two or more points is sufficient. In some cases, once the system is balanced, the flow metering may no longer be needed or is used periodically to check the system balance.

**Figure 4.9: An air-cooled chiller for an air conditioning system.**



### Application Characteristics and Challenges

- HVAC systems are generally installed by commercial contractors, so costs and ease of use are primary drivers.
- Absolute accuracy of the measurement may not be a priority, as balancing of ducting flows is the typical application need.

### Suitable Technologies

Rosemount Technology	Installation Guidelines
Annubar Averaging Pitot Tube	10.4.1, 10.5.2, 10.7.2
MultiVariable Transmitter	8.10, 10.3.3, 10.7.4

#### 4.2.4.3 Scrubbers

##### Primary Function of Application

Scrubbers are systems that remove noxious gases from the flue gas in combustion or other production systems and are placed between the burner output and the flue stack. See [Figure 4.10](#). Several scrubber systems may be used in parallel to raise the efficiency of operation, and flow meters can be used to balance the flow rates through each system. The ducting can also be irregular in shape and an in-situ calibration using a pitot traverse may be desirable. See [Chapter 10](#).

**Figure 4.10: A utility scrubber for emissions reduction.**



### Application Characteristics and Challenges

- The scrubber inlet flow is hot and may be laden with flue ash. Intermittent purging may be needed to keep systems operational.
- An assessment of the system is recommended before designing flow meter equipment.
- Low DP signals require careful design of the impulse tubing and a periodic check of the DP transmitter zero trim.

### Suitable Technologies

Rosemount Technology	Installation Guidelines
Annubar Averaging Pitot Tube	10.4.1, 10.5.2, 10.7.2
MultiVariable Transmitter	8.10, 10.3.3, 10.7.4

### 4.2.4.4 Air Ventilation in Mines

#### Primary Function of Application

Air flow in and out of mines is important for safety purposes, and it may also be required for emissions control such as monitoring methane emissions from coal mines. See [Figure 4.11](#). The ventilation air may be heated or cooled depending on the mine location. For example, if the mine is located near a geothermal field, refrigerated air is pumped into the mine to reduce the interior temperature. The reverse occurs in cold climates, where heated air prevents frozen water lines and provides a safer working environment for personnel. These are typically large duct applications, so the preferred DP flow technology is an averaging pitot tube.

**Figure 4.11: A large underground mine shaft.**



### Application Characteristics and Challenges

- Ventilation applications are challenging due to the size of the ducts, flow disturbances, and access for installation.
- Finding a location to put in a flow measurement point may require a preliminary flow field assessment.
- Performance needs may require in-situ calibration using the pitot traverse method.
- Due to low differential pressure signals, the DP transmitter zero trim should be checked as part of regular maintenance.

### Suitable Technologies

Rosemount Technology	Installation Guidelines
Annubar Averaging Pitot Tube	10.4.1, 10.5.2, 10.7.2
MultiVariable Transmitter	8.10, 10.3.3, 10.7.4

#### 4.2.5 Furnace Fuel

As with air flow, gas flow measurement to industrial furnaces such as boilers, blast furnaces, dryers, or kilns is needed to optimize air/fuel ratios to achieve greater efficiency and reduced emissions. See [Figure 4.12](#). For some regulated fixed-emitting processes, fuel flow measurement can be used in lieu of stack flow to satisfy emission monitoring requirements. Approval of the proposed measurement may be needed and may require periodic flow meter calibration. Both orifice and averaging pitot tube DP flow meters can be used for most liquid and gas fuel applications.

**Figure 4.12: A furnace fuel control skid.**



#### Application Characteristics and Challenges

- Adequate straight run is a common concern in these applications.
- If the installation is to satisfy the requirements of emission control applications, it may require regular calibrations.

### Suitable Technologies

Rosemount Technology	Installation Guidelines
Traditional or Conditioning Orifice	10.4.2 - 10.4.4, 10.5.3, 10.5.4, 10.7.3
Annubar Averaging Pitot Tube	10.4.1, 10.5.2, 10.7.2
MultiVariable Transmitter	8.10, 10.3.3, 10.7.4

#### 4.2.6 Compressed Air

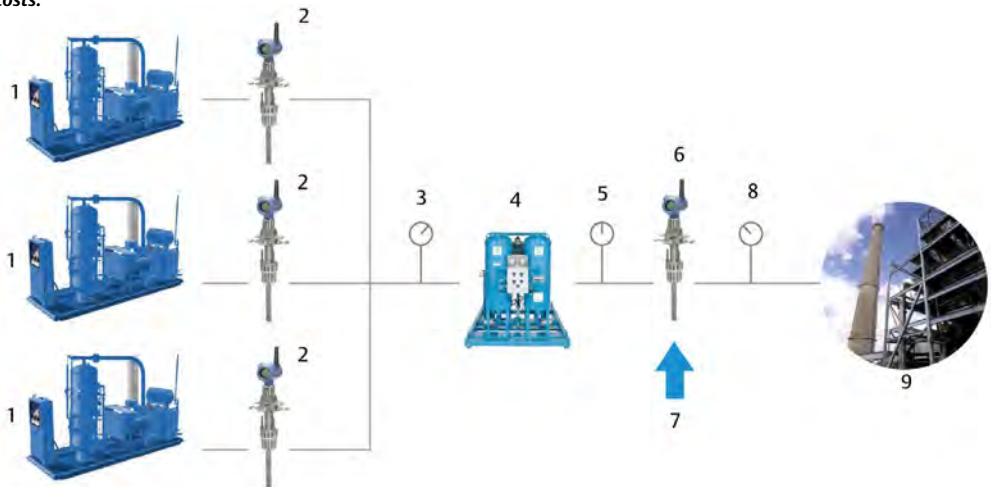
##### Primary Function of Application

Compressed air is important to a number of industrial processes, and it is used for everything from actuating valves and other process controls to cleaning and purging equipment. For large systems, monitoring compressed air flow to manufacturing areas can be used to determine costs and usage.

Monitoring daily air usage may reveal possible leaks and also allow optimizing compressor staging to improve energy efficiency. When selecting a flow meter for these measurement points, it is crucial to consider permanent pressure loss and performance needs for the application. This is an ideal application for averaging pitot tubes since they create very little pressure loss in a compressed air system.

Upgrading a traditional system from orifice plates to averaging pitot tubes and also instituting a leak detection and repair program can lead to significant energy savings. See [Figure 4.13](#) for an example.

**Figure 4.13: Utilizing averaging pitot tubes instead of an orifice plate improves overall efficiency and reduces utility costs.**



1. Compressors
2. Pressure Loss from Flow Measurement Point  
With Annubar Flow Meter = 5 mbar (0.073 psi)/point  
If 0.65  $\beta$  Orifice Plate = 15 mbar (0.218 psi) total  
= 60 mbar (0.870 psi)/point  
= 180 mbar (2.610 psi) total
3. 6.5 Bar (94.28 psi)
4. Pressure Loss from Driers = 0.5 Bar (7.25 psi)
5. 6.5 Bar (94.28 psi)
6. Main Line Measurement

7. Pressure Loss from Flow Measurement Point  
With Annubar Flow Meter = 16 mbar (0.232 psi)  
If 0.65  $\beta$  Orifice Plate = 192 mbar (2.784 psi)
8. Approximately 6.0 bar (87 psi) with Annubar Flow Meters  
Approximately 5.8 bar (84 psi) if 0.65  $\beta$  Orifice Plate Flow Meters
9. Compressed Air Sent For Use in Plant

Total Pressure Loss from Annubar Flow Meters = 0.031 Bar (0.45 psi); If 0.65  $\beta$  Orifice Plates = 0.372 Bar (5.40 psi)

### Application Characteristics and Challenges

- Flow metering of compressed air systems requires the lowest pressure-loss flow meter technologies. For a comparison of primary element permanent pressure losses, see [Figure 8.7](#). Evaluation of the compressed-air system is needed before specifying flow measurement due to the potential for low flow rates.
- Changes in the pressure and temperature at the measurement point should be assessed against performance needs to determine whether a compensated flow transmitter should be specified. The potential for low DP signals may require that the periodic maintenance include a DP transmitter zero trim.
- Long-term operation should consider the buildup of moisture in the primary sensor. Installation orientation should be such that water buildup in the impulse tubing is prevented.

### Suitable Technologies

Rosemount Technology	Installation Guidelines
Annubar Averaging Pitot Tube	<a href="#">10.4.1</a> , <a href="#">10.5.2</a> , <a href="#">10.7.2</a>
MultiVariable Transmitter	<a href="#">8.10</a> , <a href="#">10.3.3</a> , <a href="#">10.7.4</a>

### 4.2.7 Dissolved Air Flotation Cell

#### Primary Function of Application

In mineral processing, air flow into a dissolved air flotation cell is an important measurement to make the processing of mined ores economically feasible. See [Figure 4.14](#). The air flow into these cells creates bubbles that capture hydrophobic minerals containing metals such as copper or lead. The amount of air pumped into a cell must be controlled, and flow metering allows this. Averaging pitot tubes are the preferred DP flow technology because they create low permanent pressure loss and are easy to install.

**Figure 4.14:** A dissolved air flotation cell for separation of metals.



### Application Characteristics and Challenges

- Higher performance requirements for averaging pitot tube technology requires that the pipe diameter be measured one diameter upstream of the mounting.
- Proper installation of the averaging pitot tube is also needed, including boring the proper hole size in the pipe and making sure that there is sufficient straight piping upstream of the meter.
- Using a totalizing flow computer such as a multivariable transmitter allows the measurement of the prescribed volume of air needed.

### Suitable Technologies

Rosemount Technology	Installation Guidelines
Annubar Averaging Pitot Tube	10.4.1, 10.5.2, 10.7.2
MultiVariable Transmitter	8.10, 10.3.3, 10.7.4

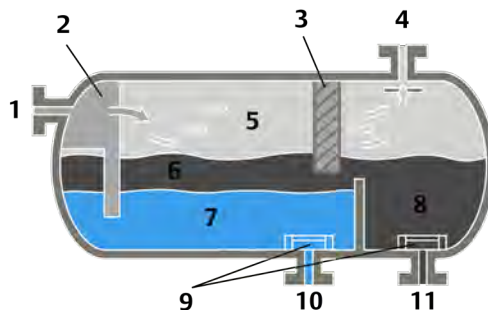
## 4.3 Special Applications

### 4.3.1 Wet Gas

#### Primary Function of Application

A wet gas is defined as a gas with a small amount of liquid present. Generally, the flow of the gas rather than the liquid is of primary interest, and the need to determine the equivalent dry gas flow rate is the primary goal. The liquid present in the gas may be water or hydrocarbon liquids (also called condensable gases) or a combination of both. The measurement of wet gas flow is a rather new endeavor, but it has become increasingly important over the last several years due to the increased use of hydraulic fracturing, also called fracking, to release gas deposits. The many wells created using this method for gas production have encouraged the development of methodologies to compensate for the presence of fracking fluid and other liquids that come out with the gas. While a separator can be used to remove the liquids from the gas, the size and cost of these devices prevents their use for production purposes. [Figure 4.15](#) shows an example of a horizontal separator that is commonly found in upstream oil and gas production.

**Figure 4.15:** An example of a horizontal separator typically used to separate oil, water, and gas from production wells.



- |                 |                   |
|-----------------|-------------------|
| 1. Inlet        | 7. Water          |
| 2. Slug Catcher | 8. Oil            |
| 3. Demister     | 9. Vortex Breaker |
| 4. Gas Outlet   | 10. Water Outlet  |
| 5. Gas          | 11. Oil Outlet    |
| 6. Oil          |                   |

Typically, a wet gas will have a gas volume fraction (the ratio of the gas volume to the total gas and liquid volume) of 90 percent or greater. For gas fractions less than 90 percent, the fluid is considered multi-phase and it is separated or measured using meters that are specifically designed to measure both the gas and liquid flow streams.

Wet gases are classified by the flow rates and the densities of each phase. A factor developed for this purpose called the Lockhart-Martinelli number, or  $X_{LM}$ , is used to measure the effects of the liquid in the gas and is given by:

$$X_{LM}^{(1)} = \frac{Q_{m-L}}{Q_{m-G}} \sqrt{\frac{\rho_G}{\rho_L}}$$

Where:

- $Q_{m-L}$  Mass flow of the liquid
- $Q_{m-G}$  Mass flow of the gas
- $\rho_G$  Density of the gas
- $\rho_L$  Mass average density of the liquids

Typically, wet gas flows where the value of  $X_{LM}$  is no greater than 0.3 are characterized using this method.

Measuring the equivalent dry gas flow rate is used to optimize the flow of gas from the fields (i.e., plays) and determine the drop-off in production from a well. This may indicate that servicing is needed or that a well is reaching the end of its productive life.

Almost all flow meters measuring a wet gas flow will read too high, or over read, due to the presence of the liquid. The percent of over reading can be predicted based on testing the meter under varying liquid load conditions. The over reading (OR), is defined by:

$$OR = \frac{\text{Wet Gas Mass Flow}}{\text{Dry Gas Mass Flow}}$$

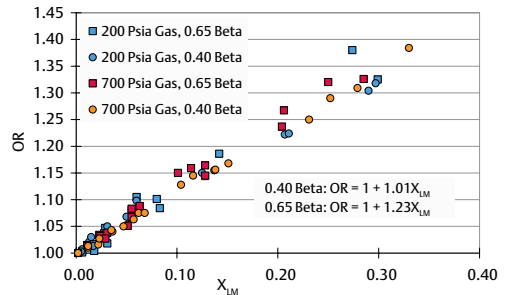
For a DP flow meter, this can be reduced to:

$$OR = \sqrt{\frac{\Delta P(\text{WetGas})}{\Delta P(\text{DryGas})}}$$

Figure 4.16 shows a plot of over reading vs. the Lockhart-Martinelli number for the Rosemount 1595 Conditioning Orifice Plate. Once the gas volume fraction is determined, the over reading of the meter is calculated, and the equivalent dry gas flow rate is then calculated by:

$$Q(\text{DryGas}) = \frac{Q(\text{WetGas})}{OR}$$

**Figure 4.16: Example correlation when correcting for dry gas flows for a wet gas application using a 3-in. (80 mm) Rosemount 1595 Conditioning Orifice Plate for a 0.65 beta. Tests were conducted at Colorado Experiment Engineering Station, Inc. (CEESI).**

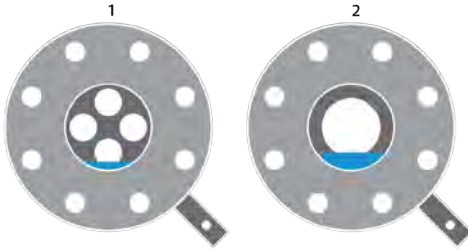


Condensable liquids will always collect in the bottom of piping for wet gas flow applications. Traditional orifice plates have an option for a drain/vent hole that is drilled into the plate at the pipe wall to pass liquids. If liquid buildup is collecting at a higher rate than the hole can pass, the plate becomes a dam and the collecting liquid changes the pipe area (see Figure 4.17), which affect the performance. The Rosemount Conditioning Orifice Plate can avoid this problem if the plate is oriented with one hole at the bottom of the pipe. In this orientation, the collection of liquids is greatly reduced.

<sup>1</sup> Lockhart, R.W., Martinelli, R.C.; Chem. Eng. Prog., Vol. 45. 1949, pp. 39–48.



**Figure 4.17:** A Conditioning Orifice Plate has a much smaller dam height than a comparable traditional orifice plate.



1. Conditioning Orifice Plate
2. Traditional Orifice Plate

### Application Characteristics and Challenges

- Using flow meters for wet gas applications requires sufficient knowledge of wet gas properties. Flow meters cannot detect the amount of liquid in the gas, but by knowing the gas fraction and the densities of the gas and liquid phases, the over reading can be calculated and the dry gas flow determined.
- The installation of traditional orifice meters may require a drain hole in the plate to allow liquids to pass through the plate. Using a Rosemount Conditioning Orifice Plate may eliminate the need for a drain hole if oriented properly.
- Using this method to calculate the dry gas flow can add additional error, often 2-3% uncertainty, to the reading of the dry gas flow rate.

### Suitable Technologies

Rosemount Technology	Installation Guidelines
Traditional, Conditioning Orifice, and Venturi	10.4.2 - 10.4.4, 10.5.3, 10.5.4, 10.7.3; consult local Emerson representative for Venturi
MultiVariable Transmitter	8.10, 10.3.3, 10.7.4

## 4.4 Gas Density

DP flow meters require the gas density over the range of application conditions to determine the flow rate. Density can be determined using several methods of calculation, or for pure gases, can be taken from a table of values. The pressure and the gas temperature at the point of measurement will affect the density value. Compensating for changing pressure and temperature should be determined based on the percent change of these values and the required performance. The potential error in flow rate for a DP flow meter is half the percentage change in the density from a given average value, or:

$$\Delta Q(\%Change) = 0.5 \times \Delta \rho(\%Change)$$

The percent change in the temperature should be determined using absolute temperature units (°R or K), not the relative temperature units (°F or °C). See [Chapter 2](#) for more information on gas density.

Flow computers used for DP flow metering can accept either pressure, temperature, or both inputs, and calculate the gas density. Multivariable transmitters provide a simple way to install and configure partially or fully compensated gas flow measurement, and this compensation accounts for varying gas densities.

### 4.4.1 Gas Expansion Factor

The gas expansion factor, abbreviated  $Y_1$  ( $\epsilon$ ) for orifice plates and  $Y_A$  ( $\epsilon_A$ ) for Annubar flow meters, accounts for the change in the density of the gas as the flow goes through or around the meter. The factor is determined experimentally from data and is calculated using an equation. The effects of the gas expansion factor are negligible for moderate flow rates at pipe pressures over 100 psig. High velocity flow rates at low pressure will cause a greater effect. This equation is programmed into most flow computers used for DP flow meters. If a flow computer is not used, the value for  $Y_1$  or  $Y_A$  must be calculated and used in the equation when optimum accuracy of the flow rate is desired. See [Chapter 3](#) for more information on the gas expansion factor.

## 4.5 Issues of Gas Composition

The composition of a flowing gas is represented by the types and percent quantity of each pure gas in the mixture. In most cases when a gas mixture is measured, the flow of one or more of the constituent gases is needed, so this information is usually available. The overall gas parameters can be calculated when the composition is known. Occasionally, the constituents are not known and are not needed, such as when the gases are a byproduct of a process like waste gas, off gas, or spent gas. In these cases, density can be used to measure the gas.

### 4.5.1 Natural Gas Composition

All natural gases are a combination of two or more components of pure gases. The content of each component must be determined to provide an accurate gas density value. The local natural gas utility can provide the specific gravity of the gas, or a gas chromatograph can be used to provide a real-time update of natural gas composition. See [Chapter 2](#) for more information.

### 4.5.2 Compensating for Humidity

The combination of a gas with water vapor is found in many processes. If the water remains in the vapor state, the density can be determined and the equivalent dry gas flow calculated. Water vapor in air at atmospheric conditions is called humidity, and it can be measured using several methods. Water vapor present in air changes the density, and to a lesser degree, the viscosity. If the humidity is high enough, and the temperature drops, the water vapor in the air can condense into moisture, which may not be desirable for a process. There are many devices available for measuring ambient humidity, and for systems that draw on ambient air, this measurement can be used to adjust the air density to improve air flow measurement accuracy.

#### 4.5.2.1 Saturated and Unsaturated Gas

The amount of water vapor that can be held in a gas is based on the gas temperature. The amount of vapor in the mixture is expressed as

a partial pressure, or the pressure that would exist if only the water vapor were present at the given temperature. The higher the temperature, the more vapor can be held, and the higher the partial pressure. For a given temperature, there is a maximum amount of vapor or partial pressure that can exist in the gas, and it is called the saturation pressure,  $p_{sat}$ . A humid gas at any temperature below this value is considered unsaturated. [Table 4.1](#) shows water vapor saturation pressures at different temperatures.

**Table 4.1: Water vapor saturation pressure at different temperatures.**

Water Vapor Saturation Pressure			
Temperature, °F	Temperature, °C	Pressure, P <sub>sat</sub> , psia	Pressure, P <sub>sat</sub> , kPa
30	-1.11	0.0817	0.56
40	4.44	0.1216	0.84
50	10.00	0.1780	1.23
60	15.56	0.2561	1.77
70	21.11	0.3629	2.50
80	26.67	0.5068	3.49
90	32.22	0.6981	4.81
100	37.78	0.9492	6.54
110	43.33	1.2750	8.79
120	48.89	1.6927	11.67

#### 4.5.2.2 Calculating the Density of Humid Air

The general equation for calculating the wet gas specific gravity,  $G_{wet}$  is:

$$G_{wet} = \left[ 1 + \frac{P_{wv}}{P_f} \left( \frac{0.6220}{G_{dry}} - 1 \right) \right] G_{dry}$$

Where:

$p_{wv}$  Partial pressure of the water vapor

$p_f$  Absolute pressure of the gas

$G_{dry}$  Specific gravity of the dry gas

Since dry air has a specific gravity of 1, the equation for the specific gravity of humid air reduces to:

$$G_{wet} = \left[ 1 - \frac{0.3780 p_{wv}}{p_f} \right]$$

Another important definition is that for relative humidity,  $RH$ :

$$RH = \left[ \frac{p_{wv}}{p_{sat,T}} \right]$$

Where  $T$  denotes that the relative humidity is calculated at a specific temperature. Once the relative humidity is known, the partial pressure,  $p_{wv}$ , can be determined using the saturation pressure,  $p_{sat}$ .

Using the gas density equations from [Chapter 2](#), the density of humid air can now be calculated:

$$\rho_f \left( \frac{lb_m}{ft^3} \right) = 2.69883 \frac{G_{wet} p_f (psia)}{Z_f T_f (^{\circ}R)}$$

for U.S. Customary (USC) Units, and

$$\rho_f \left( \frac{kg}{m^3} \right) = 3.48341 \frac{G_{wet} p_f (kPa)}{Z_f T_f (K)}$$

for SI Units

### Example:

An air duct system supplies combustion air to a boiler. The air is 80 °F (27°C), and the pressure is 15.05 psia (103.77 kPa). If the relative humidity is 50%, calculate the humid air specific gravity and density.

The partial pressure of the water vapor is:

$$p_{wv} = RH \times p_{sat} = 0.5 \times 0.5068 = 0.2534 \text{ psia}$$

The specific gravity of the humid air is:

$$G_{wet} = \left[ 1 - \frac{0.3780 \times 0.2534}{15.05} \right] = 0.9936$$

The humid air density is:

$$\rho_f \left( \frac{Lbm}{ft^3} \right) = 2.69883 \frac{0.9936 \times 15.05}{1 \times (80 + 460)} = 0.0747$$

In this case, the humidity in the air decreases the density by 0.6%. Ignoring this change in density for a DP flow meter will cause a 0.3% error in flow rate.

### 4.5.2.3 Correcting the Flow Meter for Humidity

If a flow meter is reading humid air flow, provided that the actual humid air density is used, a correction can be applied to obtain the equivalent dry gas flow rate. For volumetric flow, the correction is:

$$F_{wv} = 1 - \frac{p_{wv}}{p_f}$$

and

$$Q_{v-dry} = Q_{v-wet} \times F_{wv}$$

For mass flow, the correction is:

$$F_{wv,m} = 1 - \frac{0.6220 p_{wv}}{G_{wet} p_f}$$

and

$$Q_{m-dry} = Q_{m-wet} \times F_{wv,m}$$

## 4.6 Applicable Flow Meter Standards

There are several industry standards for DP flow meters. For most of the non-proprietary devices (i.e., those whose patents have expired), the standards are specific to the fabrication, finishing, installation, and use of the flow meter. For proprietary devices, standards are not usually available, but there are generic guidelines that were developed for these types of DP flow meters. [Table 4.2](#) shows a summary of DP flow meter standards.

**Table 4.2: DP flow meter standards.**

DP Flow Meter Standards				
Meter Type	Design Type	Standard Name	Application	
Orifice, Conditioning Orifice <sup>1</sup>	Non-Proprietary	ISO-5167- Part 2, AGA Report No. 3, ASME MFC-3M, ANSI 2530	Flange, Corner, Radius Taps; $\beta = 0.1$ to 0.75; Pipe ID = 50 to 1000 mm	
		ASME MFC-3M	ASME Venturi Tube; $\beta = 0.3$ to 0.8; Pipe ID = 100 to 1200 mm	
ISO 5167-Part 4		Venturi Tube; $\beta = 0.3$ to 0.075; Pipe ID = 50 to 1200 mm		
Nozzles and Venturi Nozzles		ASME MFC-3M	ISA 1932 and Long-Radius Nozzle; $\beta = 0.3$ to 0.8; Pipe ID = 50 to 1200 mm	
		ISO 5167- Part 3	ISA 1932 and Long-Radius Nozzle; $\beta = 0.3$ to 0.8; Pipe ID = 50 to 500 mm	
Small-Bore Orifice		ASME MFC-14M	Corner Taps, $\beta = 0.1$ to 0.8; Pipe ID = 6 to 40 mm	
		ISO 15377	Corner Taps, $\beta = 0.23$ to 0.70; Pipe ID >100 mm	
Averaging Pitot Tubes		Proprietary	ASME MFC-12M, Guide	Shows most averaging pitot tube designs, but only basic information
Cone Meters		Non-Proprietary	ISO 5167-Part 5	$\beta = 0.45$ to 0.75; Pipe ID = 50 to 500 mm
Wedge Meters		Non-Proprietary	ISO 5167-Part 6	H/D = 0.2 to 0.6. Nominal pipe size 2-24 in.

<sup>1</sup> Although the Conditioning Orifice Plate is proprietary, the design performs similar to a traditional orifice plate, and the specifications for fabrication are based on those shown in these standards. See [Chapters 7 and 9](#) for more information regarding standards and primary elements.

### 4.6.1 AGA Report No. 3

AGA Report No. 3 has four parts:

1. Part 1: General Equations and Uncertainty Guidelines
2. Part 2: Specification and Installation Requirements
3. Part 3: Natural Gas Applications
4. Part 4: Background, Development, Implementation Procedure, and Subroutine Documentation for Empirical Flange-Tapped Discharge Coefficient Equation

### 4.6.2 ISO 5167

Currently, ISO 5167 has 6 parts:

1. Part 1: General Principles and Requirements
2. Part 2: Orifice Plates
3. Part 3: Nozzles and Venturi Nozzles
4. Part 4: Venturi Tubes
5. Part 5: Cone Meters
6. Part 6: Wedge Meters

### 4.6.3 ASME MFC Documents

The Measurement of Fluid Flow in Closed Conduits (MFC) is a separate ASME group that produces standards related to flow metering. Documents generated are for both non-proprietary and proprietary designs. Proprietary design documents are more of a guide and how-to-use reference. The following documents are for DP flow meters:

1. MFC-3M: Measurement of Fluid Flow in Pipes Using Orifice, Nozzle, and Venturi
2. MFC-7: Measurement of Gas Flow by Means of Critical Flow Venturis and Critical Flow Nozzles
3. MFC-8M: Fluid Flow in Closed Conduits: Connections for Pressure Signal Transmissions Between Primary & Secondary Devices

4. MFC-12M: Measurement of Fluid Flow in Closed Conduits Using Multiport Averaging Pitot Primary Elements
5. MFC-14M: Measurement of Fluid Flow Using Small Bore Precision Orifice Meters

### 4.6.4 AGA Report No. 8

This report is referenced in AGA Report No. 3 and presents detailed information for the precise computations of compressibility factors and densities of natural gas and other hydrocarbon gases. It also estimates calculation uncertainties and provides model computer program listings in FORTRAN. Applications for computations of other properties are summarized in the standard, but details of those are not within the scope of the report.

### 4.6.5 GOST 30319

In Russia, GOST is the governing standards body that regulates gas flow measurements. GOST 30319.1-2015, 30319.2-2015, and 30319.3-96 cover the calculation methods of the physical properties of natural gas in a DP flow measurement. It contains three main parts:

- GOST 30319.1-2015: Natural gas. Methods of calculation of physical properties. General statements
- GOST 30319.2-2015: Natural gas. Methods of calculation of physical properties. Calculation of physical properties on base information on density of standards conditions and nitrogen and carbon dioxide contents
- GOST 30319.3-2015: Natural gas. Methods of calculation of physical properties. Calculation of physical properties on base information on component composition

### 4.6.6 ASME B31.8

ASME B31.8 is the most widely used code for the design, operation, maintenance, and repair of natural gas distribution and transmission pipelines.

This code focuses on safety aspects of the operation and maintenance of gas transmission and distribution systems and facilities. It identifies the engineering requirements necessary for the safe design and construction of pressure piping.

### 4.6.7 Other Standards

Other international standards common in natural gas flow measurement include ISO 20765-1:20053 and ISO 6976:19954. ISO 20765 uses the base of the AGA Report No. 8 equation of state to calculate the gas phase thermodynamic properties of natural gas. ISO 6976 contains the information to calculate calorific values, density, relative density, and Wobbe index from composition.

## 4.7 Additional Information

For more information, refer to the following sources:

1. Standards of Performance for New Stationary Sources, 40 C.F.R. § 60 1989.
2. Continuous Emissions Monitoring, 40 C.F.R. § 75 1994.
3. Measurement of Multiphase Flow, *API Manual of Petroleum Measurement Standards (MPMS)* Chapter 20.3, January 2013.
4. An Introduction to Wet Gas Metering, a National Measurement System Publication by NEL and TUV, 2007.
5. Measurement of Flow to Flares, *API Manual of Petroleum Measurement Standards (MPMS)* Chapter 14:10, June 2012.





# 5

## Liquid Applications

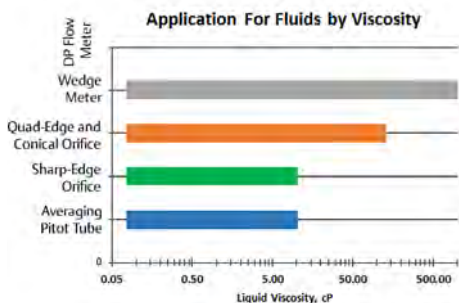
	<b>Topic</b>	<b>Page</b>
5.1	Introduction	80
5.2	Common Applications	80
5.3	Special Applications	91
5.4	Density Requirements	91
5.5	Challenges and Considerations for Use	92
5.6	Applicable Flow Meter Standards	92

## 5.1 Introduction

Differential pressure (DP) flow technology is commonly used to measure liquid flows due to its flexibility, reliability, accuracy, and ease of use. Examples that are commonly measured include water, hydrocarbons, and liquefied gases. More difficult applications such as slurries can also be measured successfully with specialized solutions. In addition to liquid applications, this chapter will discuss the material, physical, and engineering considerations that must be considered to ensure an accurate and reliable liquid flow measurement.

A primary concern when measuring liquid flows is viscosity. *Figure 5.1* shows the applicable viscosity ranges for different primary elements. These guidelines should be kept in mind as primary elements are selected for liquid flow applications.

**Figure 5.1: Typical ranges of viscosity for several types of DP flow meter primary elements. The x-axis is logarithmic scale.**



## 5.2 Common Applications

### 5.2.1 Cooling Water

#### *Primary Function of Application*

The majority of industrial processes use or generate heat during the transformation of raw materials into finished products. Water is used extensively as a cooling medium because it is inexpensive, safe, efficient, and readily available. Flow measurement is a crucial component to process control and environmental compliance

in cooling water applications. See *Figure 5.2*. Some applications, such as chemical processing and nuclear power generation, have more stringent control requirements due to additional safety functions that are associated with these processes to prevent loss of control and industrial incidents.

Make up water, or water added to make up for water lost through evaporation, often must be measured to ensure adequate water volume. This allows an accurate record of water usage in the system, and any deviation from normal use can help diagnose system leaks or other operational problems.

**Figure 5.2: An industrial cooling tower, which uses evaporation of water to remove large amounts of heat from an industrial process.**



Accurate flow measurement, whether for process optimization or mandated by environmental regulatory compliance, dictates measuring cooling water flows both in and out of heat exchangers. This is especially important for high-heat systems such as blast furnace tuyere cooling systems. A tuyere is a nozzle through which air is blown into a blast furnace. See *Figure 5.3*. A leak in the cooling water circuit changes the dynamics of the cooling system and decreases the performance and efficiency of the furnace. In addition to efficiency concerns, damage can also occur if water leaks into a furnace.

Flow control is also beneficial when chemical dosing is present. Accurately balancing chemical feed to system flow rates ensures efficient use of treatment chemicals for optimum results.

Nuclear cooling applications require stringent control. Situations with unacceptably low flow



that create a safety issue are top priority, but there are other conditions that must be tightly monitored as well. Among these are detection of leaks, operation of safety valves and sampling systems, and chemical treatment injections. Flow measurement equipment in nuclear applications often requires ASME N-type or NPT-type certificates that verify their suitability for the application and environment.

**Figure 5.3: A blast furnace, where cooling systems should be monitored for proper flow to prevent damage or hazardous conditions.**



### Application Characteristics and Challenges

- Accurate flow measurement is important to ensure balanced system flows and adequate cooling capacity.
- Modern cooling systems can be highly complex; monitoring flow at different points in the process helps to maintain an efficient operation.

- Some industries, such as chemical processing and nuclear power generation, have more stringent requirements for flow measurement that may require Safety Integrity Level (SIL)-certified flow measurement devices.
- High flow rates and large line sizes require economical metering technologies with robust construction. Averaging pitot tubes can be used to accomplish this with a lower installed cost.

### Suitable Technologies

Rosemount Technology	Installation Guidelines
Traditional or Conditioning Orifice	10.4.2 - 10.4.4, 10.5.3, 10.5.4, 10.7.3
Annubar Averaging Pitot Tube	10.4.1, 10.5.2, 10.7.2

## 5.2.2 Boiler Systems

### Primary Function of Application

A boiler is a closed vessel in which water or other fluid is heated to the point at which it turns into a vapor. Water is primarily used to produce steam in these applications. As the water in the boiler turns to steam and exits the boiler, that water must be replaced to maintain a steady-state operation. This is the function of a feedwater system. Once steam reaches the point of use, it gives up some of its heat energy and condenses back into liquid water. This water, or condensate, can be returned back to the boiler via the condensate system and reused, which improves efficiency and reduces the cost of operation. The use and measurement of steam is discussed in [Chapter 6](#).

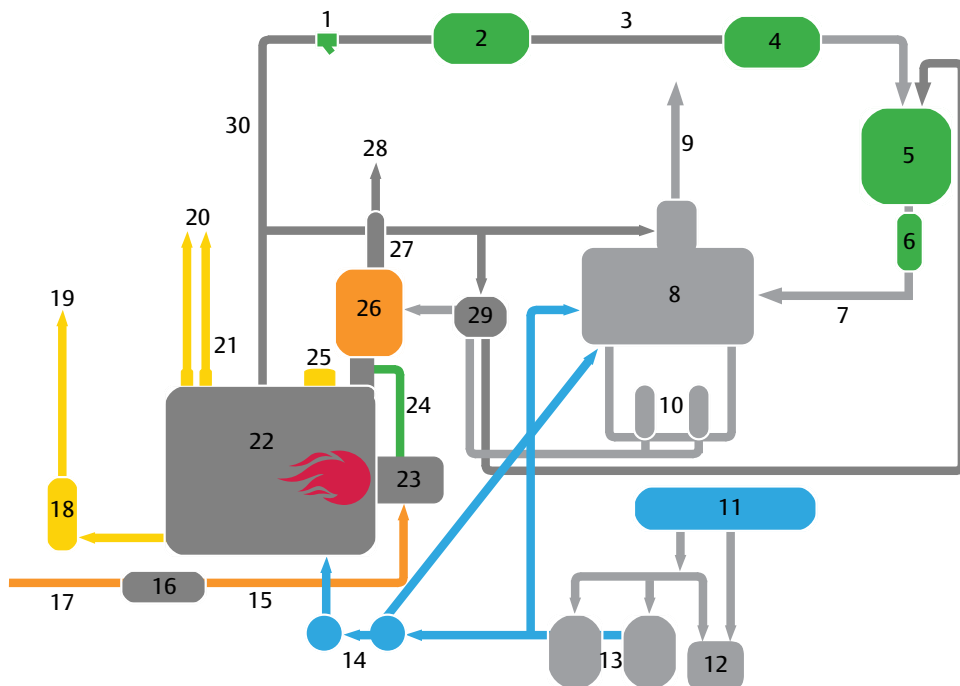
### 5.2.2.1 Boiler Feedwater

#### Primary Function of Application

Measurement of boiler feedwater represents another common application. See [Figure 5.4](#). As boilers produce steam, feedwater pumps must supply a constant flow of water to ensure steady-state operation as well as safeguard against dangerously low boiler water levels.

## 5 – Liquid Applications

Figure 5.4: A schematic view of a boiler feedwater system.



- |                                   |  |
|-----------------------------------|--|
| 1. Steam Trap                     | 16. Fuel Heater                              |
| 2. Process Equipment              | 17. Fuel In                                  |
| 3. Low-Pressure Steam             | 18. Blowdown Separator                       |
| 4. Condenser                      | 19. Vent                                     |
| 5. Condenser Tank                 | 20. Safety Valve Vents                       |
| 6. Pump                           | 21. Safety Valves                            |
| 7. Condensate Return from Process | 22. Boiler                                   |
| 8. Deaerator                      | 23. Burner                                   |
| 9. Vent                           | 24. Flue Gas Recirculation                   |
| 10. Pumps                         | 25. Blower                                   |
| 11. Water Source                  | 26. Economizer                               |
| 12. Brine                         | 27. Stack                                    |
| 13. Softeners                     | 28. Exhaust                                  |
| 14. Chemical Feed                 | 29. Preheater                                |
| 15. Fuel Out                      | 30. High-Pressure Steam to Process Equipment |

This feedwater is often a mix of returned condensate and treated make up water that meets the purity requirements of the boiler.

Control of the feedwater supply requires measurement of boiler steam drum level and system flow rates. Accurate flow measurement is important to system reliability and to maintain a stable steam output.

### Application Characteristics and Challenges

- Boiler feedwater systems often operate at high pressures and variable flow rates, which can be accommodated with modern DP flow meters.
- Compact installation footprints often lead to challenges with straight run requirements, which can be mitigated by using Conditioning Orifice Plate technology.

## Suitable Technologies

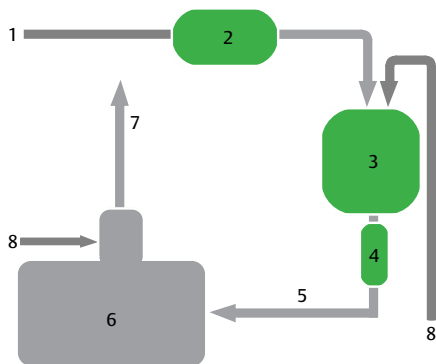
Rosemount Technology	Installation Guidelines
Annubar Averaging Pitot Tube	10.4.1, 10.5.2, 10.7.2
Traditional or Conditioning Orifice	10.4.2 - 10.4.4, 10.5.3, 10.5.4, 10.7.3
MultiVariable Transmitter	8.10, 10.3.3, 10.7.4

### 5.2.2.2 Condensate System

#### Primary Function of Application

Steam is used throughout many industries to provide process heat. Once steam has given up most of its usable energy, it condenses back into water, which is referred to as condensate. This condensate still has a high heat content and is very pure, so it can be returned to the boiler with the feedwater to reduce the make up water and energy requirements as shown in [Figure 5.5](#). Measurement of condensate return is thus important to monitor total system efficiency and identify opportunities for improvement.

**Figure 5.5: A diagram of a simple condensate system.**



- |                       |                                   |
|-----------------------|-----------------------------------|
| 1. Low-Pressure Steam | 5. Condensate Return from Process |
| 2. Condenser          | 6. Deaerator                      |
| 3. Condensate Tank    | 7. Vent                           |
| 4. Pump               | 8. Water from Preheater           |

## Application Characteristics and Challenges

- Condensate systems can be spread out and complex. Wireless DP flow meters can monitor these points.
- Flow may be intermittent depending on the amount of condensate that is returned.
- Conditioning Orifice Plate technology can be used to eliminate straight run requirements in challenging installations.

## Suitable Technologies

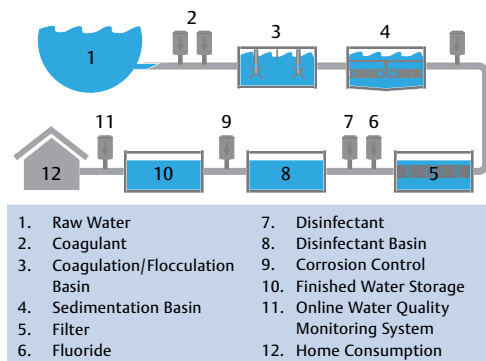
Rosemount Technology	Installation Guidelines
Annubar Averaging Pitot Tube	10.4.1, 10.5.2, 10.7.2
Traditional or Conditioning Orifice	10.4.2 - 10.4.4, 10.5.3, 10.5.4, 10.7.3

### 5.2.3 Commercial and Residential Potable Water

#### Primary Function of Application

All stages of the municipal water treatment process, including sediment removal, filtration, disinfection, and dosing, must be accurately measured and controlled in order to ensure good results and regulatory compliance. See [Figure 5.6](#). Accurate, consistent flow measurement is also required throughout the distribution system to diagnose leakage and monitor throughput for billing purposes.

Figure 5.6: A representative potable water system.



### Application Characteristics and Challenges

- Water must be moved consistently and requires flow measurement and control through the various treatment stages.
- Traditional flow meters for large line sizes can have high capital costs; insertion-style meters such as Rosemount™ Annubar™ Averaging Pitot Tubes are a more economical option.
- Underground piping restricts access for installation and maintenance of measurement points. Insertion-style meters such as averaging pitot tubes can accommodate the electronics above grade for easy access and maintenance.
- Complex distribution systems require monitoring at multiple points over long distances.

### Suitable Technologies

Rosemount Technology	Installation Guidelines
Annubar Averaging Pitot Tube	10.4.1, 10.5.2, 10.7.2
Traditional or Conditioning Orifice	10.4.2 - 10.4.4, 10.5.3, 10.5.4, 10.7.3

## 5.2.4 Hydrocarbon and Custody Transfer Applications

### Primary Function of Application

The petroleum industry is usually divided into three major components: downstream (refining), midstream (transport), and upstream (production). DP flow has widespread applications in the hydrocarbon industry with the most popular technology being the orifice plate. In order to choose the best technology for the fluid being measured, there is a range of application considerations including viscosity, specific gravity, and density of the fluid. Installation flexibility, installed cost, space requirements, and calibration needs should also be taken into account.

### 5.2.4.1 Downstream (Refining)

#### Primary Function of Application

Applications for DP flow measurement within a refinery are numerous and vary widely in their functions and challenges. Overall process control requires that the flow rates of individual product streams within the plant be measured. Safety Instrumented Systems (SIS) also require redundant measurements in order to shut down hazardous processes in the event of an upset. See [Figure 5.7](#).

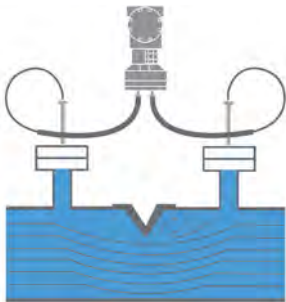
Figure 5.7: Refineries have many flow meter applications that typically require stringent design and qualification testing.



### Application Characteristics and Challenges

- High temperatures and pressures are common but can be accommodated with DP flow meters.
- Fluids may be corrosive in nature and require exotic materials of construction. Primary elements can be constructed of a variety of materials.
- Space for straight pipe can be limited, especially in plant upgrades or retrofits. Conditioning Orifice Plate technology will minimize straight run requirements. Flammable hydrocarbon service requires flanged connections and piping class isolation valves. Spool section meters can accommodate these needs and meet fire-safe requirements.
- High viscosity liquids flow in a low Reynolds number range. The conical inlet or quadrant-edged orifice can be used for this type of application. Wedge primary elements can be used for slurries or where fluids are thick and tend to clog traditional DP meters. See [Figure 5.8](#).
- Safety Instrumented Systems require multiple meters or primary elements with multiple transmitters.

**Figure 5.8: Wedge primary element using remote seals for dirty or highly viscous applications.**



### Suitable Technologies

Rosemount Technology	Installation Guidelines
Traditional or Conditioning Orifice	10.4.2 - 10.4.4, 10.5.3, 10.5.4, 10.7.3

### 5.2.4.2 Midstream (Transportation and Storage)

#### Primary Function of Application

The midstream sector focuses on the transportation and storage of crude oil from upstream producers to downstream refiners via pipeline, rail, truck, barge, or other means. Pipeline leak monitoring and transportation loading are common applications for DP flow. See [Figure 5.9](#).

**Figure 5.9: A midstream flow metering and regulation station.**



#### Application Characteristics and Challenges

- Pipelines span long distances and are often buried, limiting access to metering equipment. Insertion-style meters can be used to provide access to electronics.
- Fiscal transfer may require approved custody transfer metering equipment.
- Lines are often pigged (i.e., where a solid plug is sent down the line to remove buildup) for cleaning and inspection, requiring removal of the flow meter, a piggable design, and/or bypass piping.

**Figure 5.10: An oil and gas production field.**



### Suitable Technologies

Rosemount Technology	Installation Guidelines
Annubar Averaging Pitot Tube	10.4.1, 10.5.2, 10.7.2
Traditional or Conditioning Orifice	10.4.2 - 10.4.4, 10.5.3, 10.5.4, 10.7.3

#### 5.2.4.3 Upstream (Production)

##### Primary Function of Application

Upstream oil production encompasses the actual well sites where petroleum products are extracted from the ground. These range from offshore platforms to wells located in remote inland areas. In these applications, the low power consumption of DP flow meters is appealing as is the ability to easily replace worn components in abrasive service encountered in sand-producing wells.

Crude oil flow meter applications can be challenging if high viscosity or changing properties are present. For difficult or high-viscosity applications, a wedge meter with diaphragm-sealed DP transmitters has some advantages such as resistance to plugging and the ability to measure high temperatures.

##### Application Characteristics and Challenges

- Wells that produce liquids and gases require specific measuring solutions to account for wet gas flows or a separator to allow measurement of independent flows.
- Wells can produce oil or gas that includes sand; sand which is abrasive to production equipment. Robust primary elements such as the wedge meter are a good option.
- Remote areas with no utility access require low power consumption. DP flow meters have low power requirements and can be powered by batteries or solar panels.
- Pressures and flow can vary widely over the life of a well, requiring flow meter technologies that can handle a wide flow range. Orifice plates can be changed over the life of a well to accomplish this.

### Suitable Technologies

Rosemount Technology	Installation Guidelines
Traditional or Conditioning Orifice	10.4.2 - 10.4.4, 10.5.3, 10.5.4, 10.7.3
Wedge meter	Consult local Emerson representative

#### 5.2.4.4 Custody Transfer (Fiscal Metering)

##### Primary Function of Application

Custody transfer, also commonly known as fiscal metering, refers to the point where a fluid is being measured for sale from one party to another. An example is the sale of crude oil from a pipeline company to a downstream refinery. This transaction requires a high level of accuracy and is often governed by a standards organization. Some fiscal metering systems are designed with built-in volumetric provers to calibrate or prove the metering system at defined intervals. See [Figure 5.11](#). However, a more common way is to calibrate or prove the fiscal meter using mobile equipment or another service provider.

**Figure 5.11: Volumetric provers are typically used to do in-situ flow meter performance verification.**



### Application Characteristics and Challenges

- Often requires compliance to standards set out by various organizations covered in [Section 5.6](#).
- Flow meter may be required to meet high accuracy and repeatability requirements.

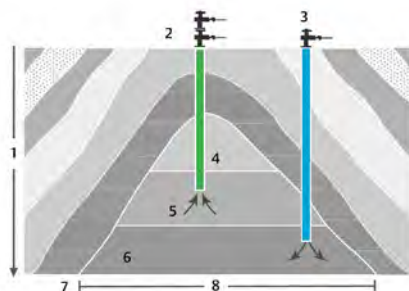
### Suitable technologies

Rosemount Technology	Installation Guidelines
Traditional Orifice	10.4.3, 10.5.4, 10.7.3.3

### 5.2.5 Hydrocarbon Recovery – Water Injection

Large volumes of water are commonly used to maintain the production of oil from aging fields. See [Figure 5.12](#). Water flooding is the most commonly used secondary oil recovery method because water is effective, inexpensive, and readily available in large volumes. The process can take decades to complete and requires careful flow monitoring in order to maximize oil recovery. The overall injection to the field is balanced with flow measurement of the injected liquids and the produced oil to maximize recovery.

**Figure 5.12: Water is pumped into oil wells via peripheral injection wells. The water drives oil toward production wells located in the center of the field.**



1. Depth	5. Oil
2. Production Well	6. Water
3. Injection Well	7. Cap Rock
4. Gas	8. Reservoir

### Application Characteristics and Challenges

- Flow control is necessary for water treatment prior to injection to maintain consistent flooding of the reservoir and to maintain efficient production.
- Measurement of water flow is critical when flooding programs are designed to reestablish reservoir pressure. Over flooding can lead to water breakthrough and reduced oil production efficiency.
- Sites are often remote and widely spread out so power may not be available except through solar panels. DP flow meters can be powered in these conditions.

### Suitable Technologies

Rosemount Technology	Installation Guidelines
Traditional or Conditioning Orifice	10.4.2 - 10.4.4, 10.5.3, 10.5.4, 10.7.3

### 5.2.6 Measuring Natural Water (Rivers, Lakes)

#### Primary Function of Application

Flow measurement in natural water systems often involves extremely high flow rates and large pipe sizes. See [Figure 5.13](#). Applications include harvest for large municipal water utility systems, penstocks from reservoirs to hydroelectric plants, and cooling water for power generation or industrial processes. Measurement is important for a number of reasons including water conservation mandates—especially monitoring to ensure minimum impact on ecological systems—leak control, and monitoring process efficiencies.

**Figure 5.13: Flow measurement through long distance municipal water gathering lines pose the dual challenges of large size and remote site conditions.**



### Application Characteristics and Challenges

- Extremely high flow rates and pipe sizes greater than 10 ft (3 m) in diameter make access challenging for flow meter installation and maintenance. Insertion meters such as averaging pitot tubes can provide solutions to these challenges.
- The piping can be in difficult and/or remote terrain. It is important to be able to troubleshoot on-site and verify performance if needed. Wireless transmitter technology can be used to reduce installation costs related to running wiring to new flow points.
- Flow measurement is critical to detect leaks in remote or underground pipeline sections.

### Suitable Technologies

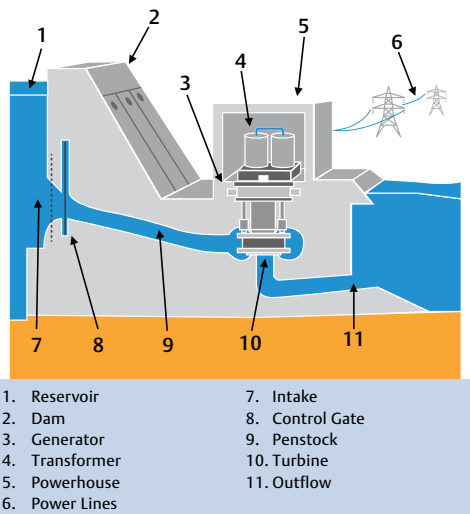
Rosemount Technology	Installation Guidelines
Annubar Averaging Pitot Tube	10.4.1, 10.5.2, 10.7.2
Venturi	Consult local Emerson representative

## 5.2.7 Large Pipeline and Penstock Applications

### Primary Function of Application

Penstocks are large pipes or culverts that feed water turbines for hydropower plants from elevated reservoirs. Monitoring the flow rate is important for controlling discharge from the reservoir, electrical output from the generator, and to determine turbine efficiency. See [Figure 5.14](#).

**Figure 5.14: A typical hydroelectric power plant installation.**



### Application Characteristics and Challenges

- The location of large water pipelines and penstocks are often underground or only accessible through vaults. Insertion-style meters are often preferred.
- Most applications of this type operate at a relatively low pressure, and the pipeline at some locations may not be full (i.e., air at the top of a horizontal section of pipe). Locating the measurement where the pipeline remains full can help ensure a successful application.
- The connection of the transmitter or secondary meter should account for preventing air in the impulse piping and/or



account for maintenance to keep the system operating properly.

### Suitable Technologies

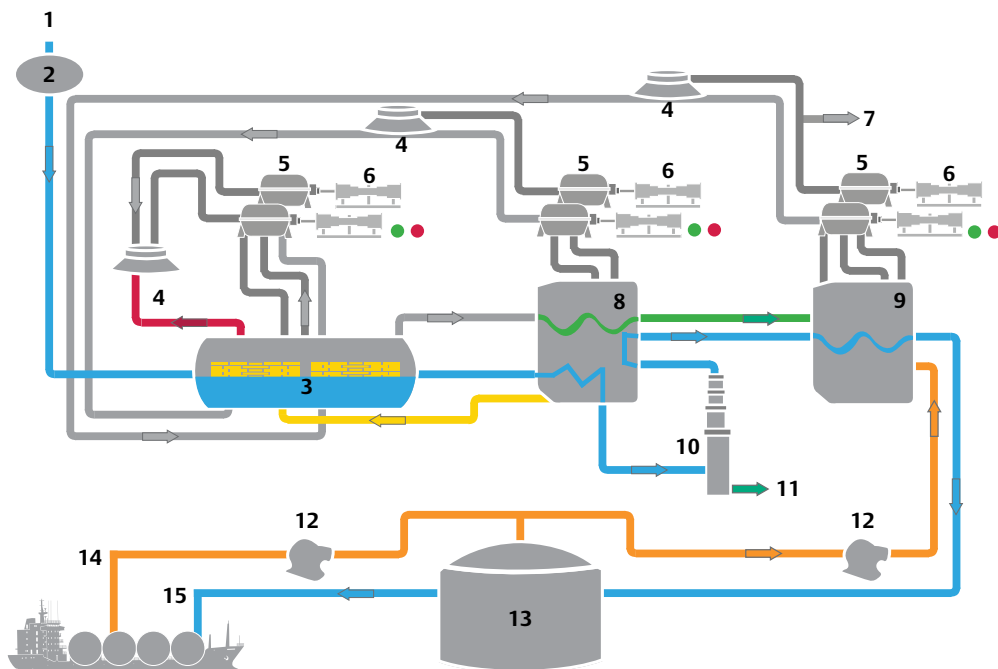
Rosemount Technology	Installation Guidelines
Annubar Averaging Pitot Tube	<i>10.4.1, 10.5.2, 10.7.2</i>
Venturi	Consult local Emerson representative

### 5.2.8 Cryogenic Flow Applications

#### Primary Function of Application

In many parts of the world, liquefied natural gas (LNG) is rapidly becoming a preferred fuel for its ability to be easily transported, particularly where pipeline construction is difficult or impossible. See [Figure 5.15](#). To produce LNG, natural gas is cleaned to remove impurities, compressed, and then cooled until it condenses into a liquid state. Before use, LNG is heated to return it to a gaseous state. Flow measurement is important during both the liquefaction and gasification processes, as well as transportation in a liquefied state.

**Figure 5.15: A gas liquefaction plant diagram. Flow rate measurement is essential for operation.**



- |  |  |
|--|--|
| <ol style="list-style-type: none"> <li>1. Raw Gas</li> <li>2. Feed Pretreatment</li> <li>3. Propane Heat Exchanger</li> <li>4. Air Fin Heat Exchanger</li> <li>5. Compressors</li> <li>6. Turbines</li> <li>7. Plant Fuel</li> <li>8. Ethylene Cold Box</li> </ol> | <ol style="list-style-type: none"> <li>9. Methane Cold Box</li> <li>10. Heavies Removal</li> <li>11. Natural Gas Liquids</li> <li>12. Vapor Blower</li> <li>13. Storage Tanks and Pumps</li> <li>14. Vapors from Ship</li> <li>15. To Ship Loading Facilities</li> </ol> |
|--|--|

### Application Characteristics and Challenges

- Liquefaction requires temperatures below -238 °F (-150 °C). Material choices (316 stainless steel is common) must be suitable for low-temperature service without embrittlement or cracking which could lead to leaks.
- Floating LNG facilities with significant space and piping restrictions make installation and maintenance challenging. Conditioning Orifice Plate technology can provide an accurate measurement in tight piping arrangements.
- LNG does not provide any lubrication, so flow meters with moving parts should be avoided.

### Suitable Technologies

Rosemount Technology	Installation Guidelines
Annubar Averaging Pitot Tube	10.4.1, 10.5.2, 10.7.2
Traditional or Conditioning Orifice	10.4.2 - 10.4.4, 10.5.3, 10.5.4, 10.7.3

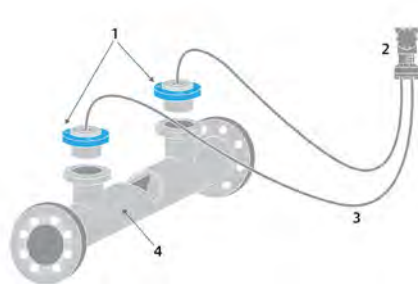
### 5.2.9 Slurries

#### Primary Function of Application

Slurries are a mixture of a fluid and a typically insoluble solid. They have a higher viscosity, making them more challenging to measure. Examples include mining slurries and pulp and paper.

Wedge meters with diaphragm seals or Venturi primary elements are generally preferred as these primary elements have a reduced susceptibility to plugging with solids. See [Figure 5.16](#).

**Figure 5.16: Wedge primary element with balanced remote seal system to reduce the susceptibility to plugging.**



1. Remote Seals (Extended)
2. Flow Transmitter
3. Armored Capillary Conduit
4. Wedge Primary Element

### Application Characteristics and Challenges

- Slurries can be abrasive and may cause wear on primary elements. Wear-resistant primary elements such as a wedge are preferred.
- Entrained solids can cause plugging in small passages. Remote seals can prevent this when paired with a primary element such as a wedge.
- Lower fluid velocities can make measurement difficult due to low DP signals.

### Suitable Technologies

Rosemount Technology	Installation Guidelines
Wedge meter	Consult local Emerson representative

## 5.3 Special Applications

### 5.3.1 Underground and Vault Installations

#### *Primary Function of Application*

Large water pipes or mains are usually buried for protection and to reduce obstruction to rights-of-way. If flow meters in these types of pipes are needed, vaults are often used to provide access. A vault is usually limited in space and provides few options for installing flow meters. See [Figure 5.17](#). An averaging pitot tube offers an advantage due to the relatively small physical size of the sensor and mounting required. If space does not allow the preferred liquid-service mounting for horizontal pipes—in the bottom half of the pipe—DP transmitter impulse plumbing should allow for air traps so that collected air can be vented. See [Chapter 10](#) for more information.

**Figure 5.17: A vault installation.**



#### *Application Characteristics and Challenges*

- If the pipeline is excavated for installation, the top or head of an averaging pitot tube should be brought above grade to allow maintenance or service at a later time.
- Large pipelines require that the averaging pitot tube be supported at both ends, so provisions and space are needed to allow installation of the opposite-end mounting hardware.
- If a DP transmitter or meter must be mounted above the primary element, provisions are needed for preventing air from becoming trapped in the impulse lines.
- For larger pipes, if an averaging pitot sensor is used, ensure that the strength of the sensor is sufficient to withstand the force of the flowing fluid.

#### *Suitable Technologies*

Rosemount Technology	Installation Guidelines
Annubar Averaging Pitot Tube	10.4.1, 10.5.2, 10.7.2
Venturi	Consult local Emerson representative

## 5.4 Density Requirements

Compressibility of liquids is almost nonexistent. Density and viscosity, however, can change as a function of temperature. The advent of the flow computer and multivariable transmitter has provided the ability to calculate the density and viscosity in real-time, using equations of state to calculate the density and viscosity of many liquids. Examples of these equations can be found in Design Institute for Physical Properties (DIPPR) 801, produced by the American Institute of Chemical Engineers (AIChE). AIChE notes that the DIPPR 801 database contains rigorously evaluated pure component data on industrially important chemical compounds.

Another source for the calculation of water density and viscosity can be found in the ASME steam tables.

Liquid specific gravity is another term used in flow metering. Specific gravity is the ratio of the flowing liquid density at the flowing temperature divided by a reference substance density at a standard temperature. The most widely used reference substance for specific gravity of solids and liquids is water, whose density at standard conditions is 1 g/cm<sup>3</sup>. In U.S. Customary (USC) units, the density of water is 62.4 lb/ft<sup>3</sup>. Since the

densities of all substances vary with temperature, the temperature for both the reference substance and the substance of interest are often included when precise values of specific gravities are given.

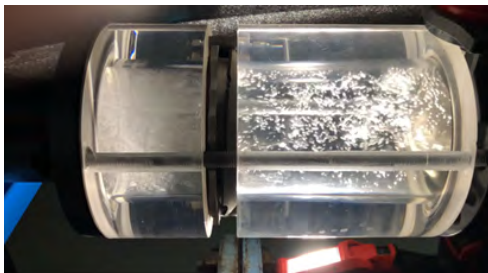
See [Chapter 2](#) for more information on liquid density and specific gravity.

### 5.5 Challenges and Considerations for Use

#### 5.5.1 Entrained Gases or Solids

Some liquid flow applications may contain entrained gases or solids. These applications can be measured with DP flow. Emerson installation guidelines take into account the possibility of entrained gases or solids since liquid flows are rarely totally clean. For large amounts of entrained solids, normal remote-mount practices with flange taps on the side and impulse piping below the pipe with drain legs to catch solids is recommended. For liquids with a high solids content, a wedge primary element with remote seals should be considered. For entrained gases, taps should be located below the horizontal axis of the pipe so any gases can rise back into the pipe. Conditioning Orifice Plates or standard orifice plates can be used in these applications. See [Figure 5.18](#). Conditioning Orifice Plates are advantageous because the four holes can be positioned to optimally allow solids or gas to pass by.

**Figure 5.18:** An example of flow going through a Conditioning Orifice Plate using air to visualize the flow structure. The flow is from right to left.



More information regarding standard installation practices can be found in [Chapter 10](#) or in the Quick Start Guides on [Emerson.com/DPFlow](http://Emerson.com/DPFlow).

### 5.6 Applicable Flow Meter Standards

There are some published standards for flow meters:

1. *Flowmeters in Water Supply (M33): AWWA Manual of Water Supply Practice 2nd Edition*, American Water Works Association, 2006.
2. Orifice Metering of Natural Gas and Other Related Hydrocarbon Fluids – Concentric, Square-edged Orifice Meters – Part 1: General Equations and Uncertainty Guidelines, *API Manual of Petroleum Measurement Standards (MPMS) Chapter 14.3.1*, September 2012.
3. Natural Gas Fluids Measurement: Liquefied Petroleum Gas Measurement, *API Manual of Petroleum Measurement Standards (MPMS) Chapter 14.8*, July 1997, reaffirmed October 2011.

# 6

## Steam Applications

	<b>Topic</b>	<b>Page</b>
6.1	Introduction	94
6.2	Steam Types and Parameters	94
6.3	Measuring Flow of Steam Using a DP Meter	102
6.4	Options for DP Transmitter Connections	106
6.5	Maintaining Wet Legs	106
6.6	Saturated Steam Applications	107
6.7	Superheated Steam Applications	109
6.8	Wet (Quality) Steam Applications	112
6.9	Applicable Flow Meter Standards	113

## 6.1 Introduction

Steam plays an important part in power generation, process heating, paper production, crude oil extraction, district heating, and many other industrial applications. Monitoring boiler output during flow rate changes allows the user to maintain required steam conditions and optimize usage. Flow metering provides users of steam with a way to track energy costs and optimize systems.

### 6.1.1. Benefits of Measuring Steam Using Differential Pressure (DP) Flow

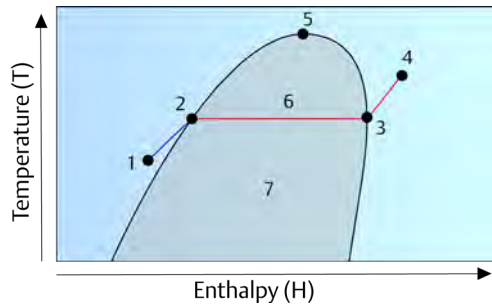
Steam behaves like a pure gas, and the properties are well defined. Measuring the flow of steam using DP flow devices has been done for over 100 years, and the requirements for a successful installation have been documented. Optimum steam flow piping is sized to give an approximate 100 to 300 ft/sec (30 to 90 m/sec) velocity. This provides a sufficient signal for a DP primary element to measure the flow rate. DP flow measures the difference in two pressures, and the temperature for most steam applications is too high to directly contact pressure instrumentation. Therefore, the primary design challenge for DP flow meters is to accurately convey the measurement of these pressures from the primary element to the instrument without exceeding pressure or temperature limits. Once this is understood, DP flow meters can be used to measure steam flow in nearly every industrial or commercial application.

## 6.2 Steam Types and Parameters

### 6.2.1 The Mollier Diagram

The steam chart, also known as the Mollier diagram, in [Figure 6.1](#) shows relationships between steam properties for ranges of pressure and temperature.

**Figure 6.1: Mollier diagram showing the transition from water to steam as heat is added.**



- |                        |                         |
|------------------------|-------------------------|
| 1. Subcooled Water     | 5. Critical Point       |
| 2. Saturated Water     | 6. Heat of Vaporization |
| 3. Dry Saturated Steam | 7. Wet Steam            |
| 4. Superheated Steam   |                         |

Note: [Figure 6.1](#) has been simplified for readability. If the wet steam is used at a lower pressure, the steam will approach saturated conditions and can still be useful.

Since steam is used in heating applications primarily as a way to convey energy, the energy content of the steam, or enthalpy, appears on most steam diagrams. The original chart, as conceived by Richard Mollier in 1904, showed the pressure and temperature lines plotted with the thermodynamic properties of enthalpy (energy per mass) and entropy (energy per mass, per degree of temperature). Steam is also used to do work or convert the steam internal energy to mechanical energy. This is most evident for a steam turbine that is used to spin an electric generator. It is easier to see these processes using a pressure volume temperature (PVT) diagram for water. The three types of steam are:

1. Saturated steam, which is represented as the line on the right edge of the two-phase area in [Figure 6.1](#).
2. Superheated steam, which is the shaded area to the right of the saturation line.
3. Wet (i.e., quality) steam, which is shown as 7 in [Figure 6.1](#).

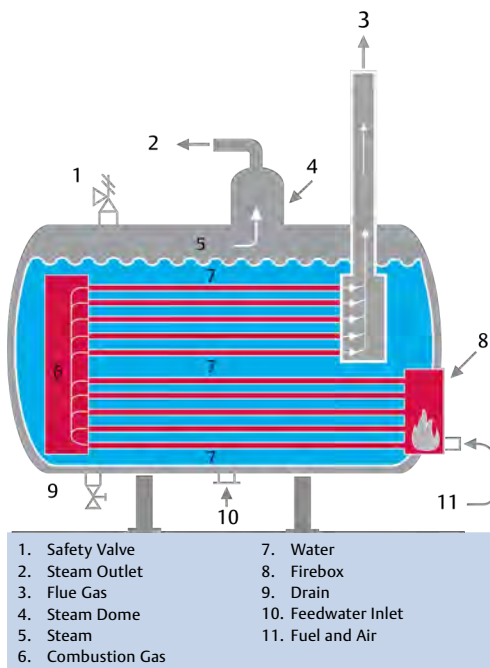
When measuring steam flow, it is only necessary to know the type of steam and the

density. However, the fact that steam can change properties with only a few degrees of temperature, or a few percent change in pressure, is helpful to know.

### 6.2.2 Saturated Steam

The steam created in a boiler is normally saturated. See [Figure 6.2](#). This means that the steam is at a temperature that has just enough energy to remain in the vapor state. If any heat is removed, the liquid water will begin to form, and the steam will become wet. If any heat is added, the steam will become superheated. This is represented in [Figure 6.1](#) as moving along the red line from point 3.

**Figure 6.2: An example of a typical fire tube boiler.**

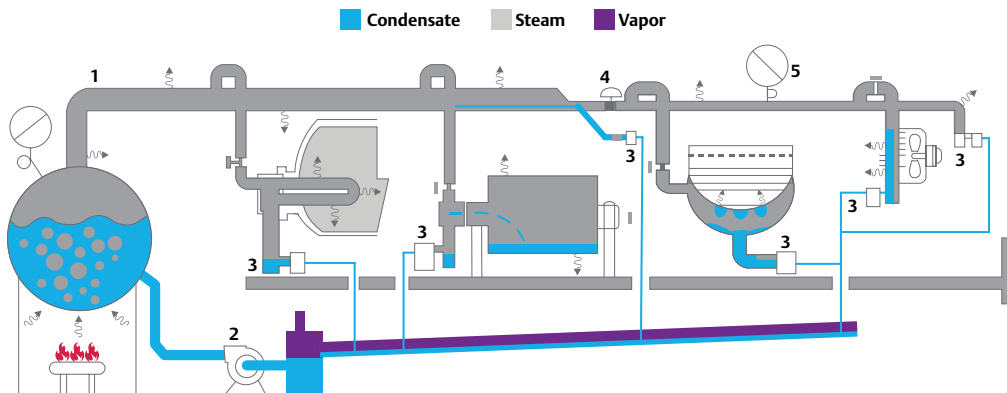


#### 6.2.2.1 The Saturation Line

As long as the vapor is at equilibrium with the liquid, the conditions will follow the saturation line of the Mollier diagram. If the steam is defined as saturated, only one fluid parameter, either temperature or pressure, needs to be measured to determine the saturated steam properties. Closer to the boiler, where the pressure tends to remain constant, temperature is typically used. Farther from the boiler, where steam travels through valves and fittings and the pressure is changing, pressure is measured to determine the local steam conditions.

For saturated conditions, the energy content is easy to determine, and the flow of steam and resulting energy flow are easy to control. When steam pressure is reduced (e.g., through a pressure regulating valve), it exists in a superheated state. Typically, steam is desuperheated by injecting water at a controlled rate. This must be carefully done to ensure that the steam remains saturated at the end of the vapor piping. At each heat exchanger, the steam condenses to liquid water (i.e., condensate) and is returned to the boiler through a device called a steam trap. Although steam piping is insulated, there is always heat loss, and the steam begins to revert to condensate as it moves away from the boiler. Condensate building up in steam lines is damaging to control valves and other components in the system. To prevent this, additional steam traps are used. In this way, the steam in the piping remains at saturated conditions. [Figure 6.3](#) shows a typical steam system with steam traps.

Figure 6.3: A typical saturated steam system.



1. High-Pressure Steam
2. Condensate Pump
3. Steam Trap
4. Pressure-Reducing Valve
5. Low-Pressure Steam

### 6.2.2.2 Finding the Density

When properly designed with steam traps, the steam will always be saturated, and the density can be determined by knowing either the temperature or pressure at the point of measurement. Steam tables will typically show the specific volume,  $v$ , rather than the density,  $\rho$ . [Table 6.1](#) shows saturated steam density and energy. The density is merely the inverse of the specific volume, or  $\rho=1/v$ . If the steam remains dry, and the pressure is controlled at the measurement point, the density will remain constant. For additional saturated steam properties, see [Chapter 12](#).

### 6.2.2.3 Steam Enthalpy and the Flow of Energy

The value of steam enthalpy is a measure of the energy content in steam. The energy required to convert water into steam has two components:

- Sensible heat, which takes the water to the boiling point at the given pressure (enthalpy of the saturated liquid), shown in [Figure 6.1](#) as the line between points 1 and 2.
- Latent heat of evaporation, which is required to convert the heated water to a steam vapor, and shown in [Figure 6.1](#) as the line between points 2 and 3.

The vapor then contains the sum between the enthalpy of the vapor and the enthalpy of the sensible heat (i.e., the enthalpy of the saturated vapor), also shown in [Figure 6.1](#) as point 3. The difference between the enthalpy of the vapor and the enthalpy of the sensible heat is the latent heat. All three heat values are included in the steam tables and are given per unit mass. When saturated steam condenses back into water, the latent heat is given up and is transferred to the surrounding piping. This is why saturated steam is ideal for heating. Notice in [Table 6.1](#) that the latent heat per pound of steam actually goes down with increasing pressure. For this reason, steam pipe pressures of 50 to 100 psia (3.5 to 6.9 bars) are usually used in heating systems. The rate of energy flow into a properly sized steam heater can be easily determined using the mass flow of steam and the latent heat of the inlet steam,  $h_{lv}$ :

$$\dot{E}_h = \dot{m} \times h_{lv}$$

Where, in U.S. Customary (USC) units (SI units):

- $\dot{E}_h$  Rate of energy flow into the heater, BTU/hr (kJ/hr)
- $\dot{m}$  Mass flow rate of steam, lb<sub>m</sub>/hr (kg/hr)
- $h_{lv}$  Latent heat of evaporation of the inlet steam, BTU/lb<sub>m</sub> (kJ/kg)



**Table 6.1: Saturated steam properties.**

Pressure, psia (bar)	Saturated Temperature, $T_{sat}$ °F (°C)	Vapor Density, $\rho_v$ , lb/ft <sup>3</sup> (kg/m <sup>3</sup> )	Liquid Density, $\rho_l$ , lb/ft <sup>3</sup> (kg/m <sup>3</sup> )	Saturated Liquid Enthalpy, $h_l$ - BTU/lb (kJ/kg)	Latent Enthalpy, $h_w$ - BTU/lb (kJ/kg)	Saturated Vapor Enthalpy, $h_v$ - BTU/lb (kJ/kg)
50 (3.5)	281 (138)	0.1174 (1.881)	57.890 (927.3)	250.2 (582.0)	924.1 (2150)	1174.3 (2731)
100 (6.9)	328 (164)	0.2256 (3.614)	56.370 (903.0)	298.7 (694.8)	888.5 (2067)	1187.2 (2761)
150 (10.3)	358 (181)	0.3317 (5.313)	55.279 (885.5)	330.2 (768.1)	863.8 (2009)	1194.0 (2777)
200 (13.8)	382 (194)	0.4371 (7.002)	54.377 (871.0)	355.7 (827.4)	842.7 (1960)	1198.4 (2787)
250 (17.2)	401 (205)	0.5423 (8.687)	53.619 (858.9)	376.2 (875.0)	824.9 (1919)	1201.1 (2794)
300 (20.7)	417 (214)	0.6479 (10.378)	52.938 (848.0)	394.0 (916.4)	809.5 (1883)	1203.5 (2799)
350 (24.1)	432 (222)	0.7540 (12.078)	52.301 (837.8)	410.0 (953.7)	794.2 (1847)	1204.2 (2801)
400 (27.6)	445 (229)	0.8609 (13.790)	51.706 (828.3)	424.2 (986.7)	779.6 (1813)	1203.8 (2800)
450 (31.0)	456 (236)	0.9686 (15.515)	51.177 (819.8)	437.3 (1017)	767.5 (1785)	1204.8 (2801)
500 (34.5)	467 (242)	1.0774 (17.258)	50.633 (811.1)	449.2 (1045)	755.1 (1756)	1204.3 (2801)
550 (37.9)	477 (247)	1.1873 (19.019)	50.150 (803.3)	461.0 (1072)	743.4 (1729)	1204.4 (2801)
600 (41.4)	486 (252)	1.2984 (20.798)	49.677 (795.8)	471.7 (1097)	731.9 (1702)	1203.6 (2800)

Flow computers used with DP flow primary elements can take a DP and pressure input and determine the energy and mass flow rates of saturated steam. The flow computer will take into account the steam properties at the measured pressure or temperature. The Rosemount™ 3051S MultiVariable™ Transmitter can be easily configured to provide these values for a variety of DP flow primary elements without the need for multiple transmitter systems.

### 6.2.3 Superheated Steam

When saturated steam flows over a surface that is hotter than the steam, heat is added and it becomes superheated. Steam can also become superheated when its pressure is reduced inside an insulated fitting such as a pressure-reducing valve/station. Since enthalpy must stay constant, a reduction in pressure means an increase

in temperature beyond saturated. Although superheated steam is less efficient for heat exchange than saturated, superheat is sometimes added intentionally to minimize the risk that the steam delivered to the process contains any liquid water. For example, when steam is used to drive a turbine for electricity generation, any entrained water can damage the turbine, and superheated steam is used to eliminate this risk.

In contrast to saturated steam, superheated steam requires knowledge of both pressure and temperature to determine the steam properties. The same steam tables are consulted to provide the properties for superheated steam. [Table 6.2](#) shows some values for superheated steam. For additional superheated steam properties, see [Chapter 12](#).

## 6 – Steam Applications

Table 6.2: Example of superheated steam values.

Pressure, psi (bar)	Temperature, °F (°C)	Saturated Temperature, °F (°C)	Degrees of Superheat, °F (°C)	Density, lb/ft <sup>3</sup> (kg/m <sup>3</sup> )	Enthalpy, BTU/lb (kJ/kg)
360 (24.82)	434 (223)	434 (223)	0 (0)	0.7753 (12.42)	1208.4 (2810.6)
400 (27.58)	460 (238)	445 (229)	15 (9)	0.8346 (13.37)	1216.5 (2829.4)
460 (31.72)	480 (249)	459 (237)	21 (12)	0.9474 (15.18)	1222.0 (2842.2)
500 (34.47)	490 (254)	467 (242)	23 (12)	1.0265 (16.43)	1223.5 (2845.7)
560 (38.61)	510 (266)	479 (248)	31 (18)	1.1315 (18.13)	1230.3 (2861.5)
600 (41.37)	520 (271)	486 (252)	34 (19)	1.2064 (19.33)	1232.6 (2866.8)
650 (44.82)	540 (282)	495 (257)	45 (25)	1.2793 (20.49)	1241.8 (2888.2)
700 (48.26)	550 (288)	503 (262)	47 (26)	1.3736 (22.00)	1243.4 (2892.0)
800 (55.16)	580 (304)	518 (270)	62 (26)	1.5283 (24.48)	1255.5 (2920.1)
900 (62.05)	600 (316)	532 (278)	68 (38)	1.7020 (22.26)	1260.6 (2932.0)
1000 (68.95)	620 (327)	545 (285)	75 (42)	1.8687 (29.93)	1266.5 (2945.7)
1100 (75.84)	640 (338)	556 (291)	84 (47)	2.0280 (32.49)	1277.8 (2972.0)
1200 (82.74)	660 (349)	567 (297)	93 (52)	2.1798 (34.92)	1280.2 (2977.6)
1300 (89.63)	670 (354)	577 (303)	93 (51)	2.3680 (37.93)	1279.6 (2976.2)
1400 (96.53)	690 (366)	587 (308)	103 (54)	2.5068 (40.18)	1296.1 (3014.5)
1500 (103.4)	700 (371)	596 (313)	259 (58)	2.6903 (43.10)	1287.9 (2995.5)

### 6.2.3.1 Finding the Density

Finding the density for superheated steam is similar to saturated steam, but the tables are more expansive, as the area on the Mollier diagram covers a larger range of pressures and temperatures. As with saturated steam, flow computers can determine the superheated steam density and enthalpy values to calculate both flow rate and energy flow.

### 6.2.3.2 Enthalpy

The enthalpy values for superheated steam are always the total enthalpy of the vapor and require knowing the pressure and temperature of the steam. When calculating the work done for real turbines, the turbine efficiency is used to determine the real exit enthalpy values, as the turbine is not 100% efficient. The values for the exit enthalpy are less than that determined just using the exit pressure.

### 6.2.3.3 The Rankine Cycle and Steam Turbines

The process of generating steam and expanding it through a turbine is described by the Rankine cycle, which is shown in *Figure 6.4*. The ideal expansion of the steam through the turbine is shown in the graph from points 3' to 4'. The work done by a steam turbine is calculated by knowing the inlet and outlet conditions of the steam, and by using the simple equation, which neglects the smaller terms of kinetic and potential energy:

$$\dot{W} = \dot{m} \times (h_{3'} - h_{4'}), \text{ where:}$$

$\dot{W}$  Rate of work (power) done by the turbine, BTU/sec (kJ)

$\dot{m}$  Mass flow rate of steam through the turbine, lb<sub>m</sub>/sec (kg/sec)

$h_{3'}$  Specific enthalpy of the steam entering the turbine, BTU/lb<sub>m</sub> (kJ/kg)

$h_{4'}$  Total enthalpy of the steam exiting the turbine, BTU/lb<sub>m</sub> (kJ/kg)

### Example:

A turbine driven by steam is driving a generator and uses steam at the following conditions:

Inlet: 1300 psia (89.6 bar), 670 °F (354 °C);

Exit: 360 psia (24.8 bar), 434 °F (223 °C), at a flow rate of 562 lb<sub>m</sub>/sec (255 kg/sec)

Assuming a 100% efficiency, calculate the rate of work done by the turbine:

From *Table 6.1*:

$$h_{3'} = 1279.6 \text{ BTU/lb}_m (2976 \text{ kJ/kg})$$

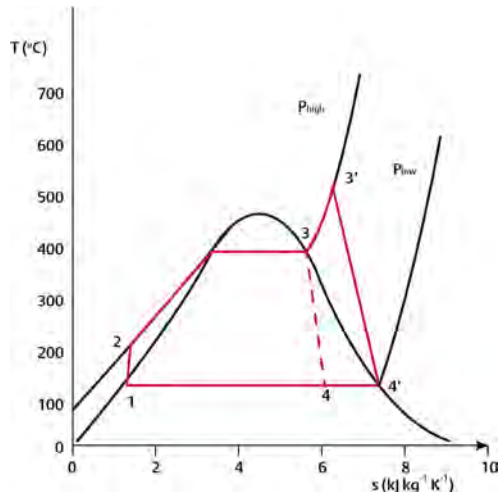
$$h_{4'} = 1208.4 \text{ BTU/lb}_m (2811 \text{ kJ/kg})$$

$$\dot{W} = (1279.6 - 1208.4) \times 562$$

$$\dot{W} = (2976 - 2811) \times 255$$

$$\dot{W} = 40,014 \text{ BTU/sec (42,170 kJ/sec) = 42.17 MW}$$

*Figure 6.4: The Rankine cycle.*



### 6.2.4 Wet (Quality) Steam

After steam has passed through a heat exchanger or if the steam is used far from the boiler, a portion may condense, resulting in liquid and vapor being present in the piping. In this case, the steam is in the two-phase region of the Mollier diagram, and this type of steam is called wet (i.e., quality) steam. Although not ideal, this type of

steam is sometimes used in a process, and it can be measured. The first issue is knowing how much of the flowing fluid is steam vapor and how much is condensate. When the mass of steam vapor in a sample of wet steam is divided by the total mass of vapor and liquid, it is called the percent quality of the steam. Quality lines are drawn on the Mollier diagram, which give an overall lower enthalpy for the steam as a portion of the latent heat has been lost.

### 6.2.4.1 Finding the Density

Measuring the flow of wet steam requires that the density be determined. For a moderate wet steam, where  $X_q$  (percent steam quality of vapor mass fraction)  $\geq 0.8$ , the moisture remains suspended in the vapor, in what is called a homogeneous state. Higher amounts of moisture will cause the condensate to drop out of the vapor and seek the lowest portion of the pipe. The calculation of the density now becomes more complex and the calculations to determine the dry steam flow more approximate. For the homogeneous state of the wet steam, the density is found by:

$$\rho_q = \varepsilon \rho_v + (1 - \varepsilon) \rho_l, \text{ where:}$$

$\rho_q$  Density of the wet steam

$\varepsilon$  Volumetric void fraction of the steam vapor, where:  $\varepsilon = 1 / \left( 1 + \frac{(1-X_q) \rho_v}{X_q \rho_l} \right)$  for the homogeneous flow of wet steam

$X_q$  Percent steam quality or vapor mass fraction,  $0 < X_q \leq 1$

$\rho_v$  Density of the steam saturated vapor at the given pressure

$\rho_l$  Density of the saturated liquid at the given pressure

### 6.2.4.2 Finding the Enthalpy

The enthalpy of wet steam is found using the equation:

$$h_q = X_q h_v + (1 - X_q) h_l$$

$h_q$  Enthalpy of the wet steam, BTU/lb<sub>m</sub> (kJ/kg)

$h_v$  Enthalpy of the steam saturated vapor at the given pressure, BTU/lb<sub>m</sub> (kJ/kg)

$h_l$  Enthalpy of the saturated liquid at the given pressure, BTU/lb<sub>m</sub> (kJ/kg)

### 6.2.4.3 Calculating the Equivalent Dry Steam Flow Rate

If the equivalent dry steam flow rate is desired, an estimate is possible using the same methods employed for a wet gas, provided the homogeneous state of the two-phase flow can be assumed. The meter will over read due to the presence of moisture, and the over reading, OR, can be calculated if the meter has been characterized for a wet gas. The Lockhart-Martinelli number,  $X_{LM}$ , is used to characterize a wet gas, and is given by:

$$X_{LM} = \frac{\dot{m}_L}{\dot{m}_G} \sqrt{\frac{\rho_G}{\rho_L}}$$

Where:

$X_q$  Percent quality of the steam, 0 to 1

$\rho_v$  Density of the saturated steam vapor, lb<sub>m</sub>/ft<sup>3</sup> (kg/m<sup>3</sup>)

$\rho_l$  Density of the saturated liquid, lb<sub>m</sub>/ft<sup>3</sup> (kg/m<sup>3</sup>)

In the case of wet steam, the gas is steam vapor, and the liquid is condensate (i.e., water). The two values of density are found on the same PVT chart under the two-phase region. The ratio of the mass flow rates is calculated by using the percent wet steam value,  $X_q$ :

$$X_q = \frac{m_v}{m_l + m_v}, \text{ or } m_l = m_v \left( \frac{1 - X_q}{X_q} \right), \text{ so that:}$$

$$\frac{m_l}{m_v} = \left( \frac{1 - X_q}{X_q} \right) = \frac{\dot{m}_l}{\dot{m}_v}, \text{ and}$$

$$X_{LM} = \frac{1 - X_q}{X_q} \sqrt{\frac{\rho_v}{\rho_l}}$$

This equation provides a way to characterize the wet steam flow. Using the same equation as used for a wet gas:

$$Q_{m,v} = \frac{Q_{m,q}}{OR}, \text{ where:}$$

- $Q_{m,v}$  Mass flow rate of the dry steam vapor
- $Q_{m,q}$  Mass flow rate of the wet or quality steam
- $OR$  Over reading of the flow meter for the calculated value of  $X_{LM}$

Prior data on orifice plates has shown a linear correlation between the value of  $X_{LM}$  and the over reading of the meter. [Figure 6.5](#) shows a plot of  $X_{LM}$  vs. the over reading of the Rosemount 1595 Conditioning Orifice Plate for two beta values and two pressures.

### Example:

Wet steam of 80 percent quality is flowing at 4200 lb<sub>m</sub>/hr (1905 kg/hr) in a 3-in., schedule 40 pipe (80 mm diameter) at 100 psia (6.9 bar) pressure. Find the steam density, the Lockhart-Martinelli number, and the over reading for a Rosemount 1595 Conditioning Orifice Plate with a 0.65 beta. Determine the equivalent dry steam flow and the specific enthalpy of the wet steam.

From [Table 6.1](#):

$$\rho_v = 0.2256 \text{ lb/ft}^3 \text{ (3.61 kg/m}^3\text{)}$$

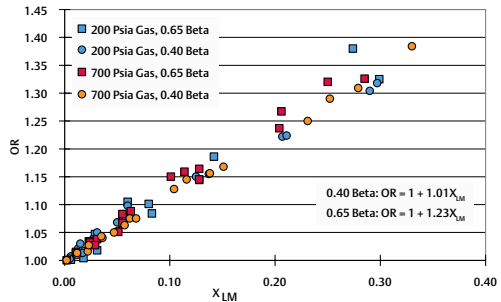
$$\rho_l = 56.37 \text{ lb/ft}^3 \text{ (902.9 kg/m}^3\text{)}$$

The void fraction for the vapor is:

$$\varepsilon = 1 / \left( 1 + \frac{(1-0.8) 0.2256}{0.8 \cdot 56.37} \right) = 0.999$$

$$\text{The wet-steam density is: } \rho_q = 0.999(0.2256) + (1 - 0.999)56.37 = 0.2817 \text{ lb}_m/\text{ft}^3 \text{ (15.88 kg/m}^3\text{)}$$

**Figure 6.5: Example correlation when correcting for dry gas flows for a wet gas application using a 3-in. (80 mm) Rosemount 1595 Conditioning Orifice Plate for a 0.65 beta. Tests were conducted at Colorado Experiment Engineering Station, Inc.**



The Lockhart-Martinelli Number is:

$$X_{LM} = \frac{1-0.8}{0.8} \sqrt{\frac{0.2256}{56.37}} = 0.0158$$

The over reading of the 0.65 beta is:

$$OR = 1 + 1.23(0.0158) = 1.0195$$

$$\text{The equivalent dry steam flow rate is: } 4200/1.0195 = 4120 \text{ lb}_m/\text{hr} \text{ (1905/1.0195 = 1869 kg/hr)}$$

$$\text{The enthalpy is: } h_q = 0.8(1187.2) + (1 - 0.8)298.7 = 1009.5 \text{ BTU/lb}_m$$

$$(h_q = 0.8(2761) + (1 - 0.8)694.8 = 2348 \text{ kJ/kg})$$

## 6.3 Measuring the Flow of Steam Using a DP Flow Meter

The installation of a DP flow meter for steam service requires the following:

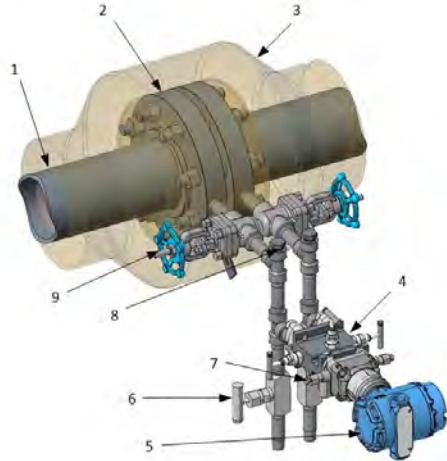
1. Steam in the vapor state at the meter and up to the point of phase change in the impulse tubing.
2. Liquid water or condensate from the point of phase change to the DP transmitter.
3. The same vertical level phase change point for the high- and low-pressure sides of the DP flow meter.

The first two requirements are accomplished by the location and orientation of the DP primary element and DP transmitter, and the appropriate use of lagging (insulation). The last is accomplished by the proper design of the impulse piping or meter connections.

### 6.3.1 Orifice Meter in Horizontal Pipes

*Figure 6.6* shows a typical arrangement for an orifice plate measuring saturated steam in a horizontal pipe. This is designated for condensing service and is meant to keep the liquid and vapor phases separate and at the same vertical level.

*Figure 6.6: A typical arrangement for an orifice plate measuring saturated steam flow in a horizontal pipe.*

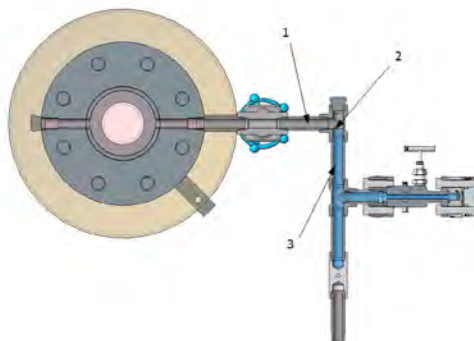


- |                                  |                                     |
|----------------------------------|-------------------------------------|
| 1. Steam Pipe                    | 6. Blow-Down/Drain Valves           |
| 2. Orifice Plate and Flanges     | 7. Flange Adaptor with Bleed Valves |
| 3. Pipe Insulation               | 8. Pipe Tee and Pipe Tee Plugs      |
| 4. 3-Valve Manifold              | 9. Gate Valves                      |
| 5. DP Transmitter and Flow Meter |                                     |

The phase change happens at the pipe tees, and there is a continuous exchange of steam vapor and condensate at this point.

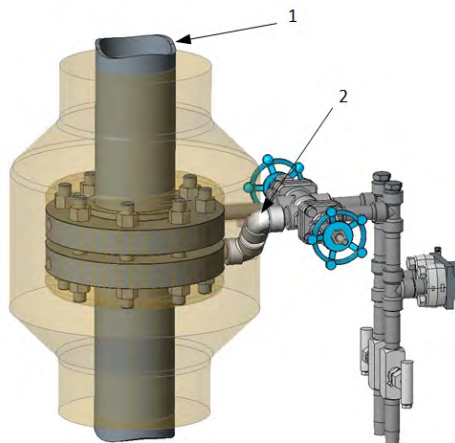
The DP transmitter should be maintained at room temperature, and the vertical impulse piping must be filled with water and properly bled during startup. Once the system comes to thermal equilibrium, the level of liquid in the impulse tubes remains constant. *Figure 6.7* shows the vapor/liquid interface. It is common at this point to zero the DP meter or transmitter to eliminate any residual DP error due to liquid legs. Because of the constant phase changes for vapor to liquid and back, the system will build up sediments that settle down the impulse piping to the blow-down valves. Periodic maintenance includes isolating the transmitter and opening these valves to remove the sediments.

Figure 6.7: Cross section of orifice plate for steam service.



1. Vapor Impulse Piping
2. Phase Change Point
3. Condensate Impulse Piping

Figure 6.8: An orifice meter installed in a vertical orientation.



1. Vertical Steam Pipe
2. Elbows to Offset Impulse Piping

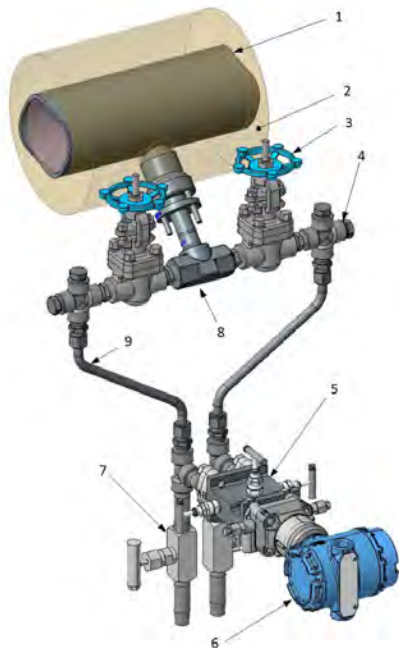
### 6.3.2 Orifice Meter in Vertical Pipes

Orifice plate installation for vertical steam piping is very similar to that for a horizontal pipe, except the two pipe nipples on the orifice flanges must be brought to the same vertical height. This prevents applying a DP to the transmitter due to the hydraulic head from the different water legs. The lower tap nipple is brought to the upper tap level. This allows condensate to drain back into the pipe. [Figure 6.8](#) shows how this is done using two piping elbows.

### 6.3.3 The Averaging Pitot Tube in Horizontal Steam Pipes

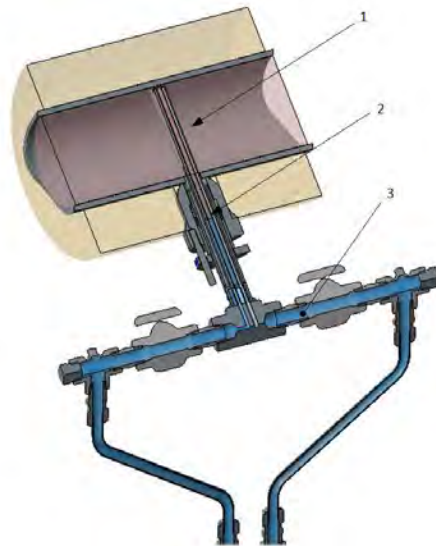
The installation for an averaging pitot tube uses the same arrangement of impulse piping described previously for orifice plates. For horizontal pipes, the averaging pitot tube sensor is mounted in the lower half of the pipe, and the phase change will occur inside the sensor. See [Figure 6.9](#). Since the high- and low-pressure chambers are mechanically bonded together, the phase change occurs at the same vertical level, eliminating DP signal differences due to liquid head. This is shown in the cross section in [Figure 6.10](#). The chambers inside of the averaging pitot tube are small, so the system should be blown down periodically to remove any sediments in the sensor.

**Figure 6.9:** An averaging pitot tube in steam service for a horizontal pipe.



- |                           |                                |
|---------------------------|--------------------------------|
| 1. Steam Pipe             | 6. DP Transmitter              |
| 2. Pipe Insulation        | 7. Blow-Down/Drain Valves      |
| 3. Gate Valves            | 8. Averaging Pitot Tube Sensor |
| 4. Pipe Crosses and Plugs | 9. Connecting Tubing           |
| 5. DP Manifold            |                                |

**Figure 6.10:** Cross section of an averaging pitot tube for horizontal steam pipe.



- |                              |
|------------------------------|
| 1. Steam Vapor               |
| 2. Phase Change Point        |
| 3. Condensate Impulse Piping |

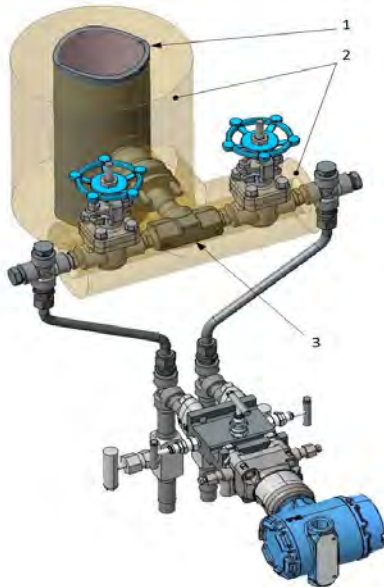
### 6.3.4 The Averaging Pitot Tube in Vertical Steam Pipes

The impulse piping for vertical pipe averaging pitot tube sensors is the same; however, to provide the same liquid-head height, the unit is constructed differently so that the sensor is rotated 90° to the head. [Figure 6.11](#) shows the arrangement for a vertical pipe. The impulse piping requires that there is steam vapor out to the pipe crosses, and the phase change happens there. This requires that the piping insulation extend over the averaging pitot tube head and out to the root valves. [Figure 6.12](#) shows this vapor-to-condensate interface. It is important that the system be completely bled of air and that the impulse tubing be filled with water to the DP transmitter diaphragms. For all of the systems shown here, the equalizer valve should never be opened unless the root valves and/or the manifold isolation valves are closed. Closing the root valves allows the equalization of the condensate



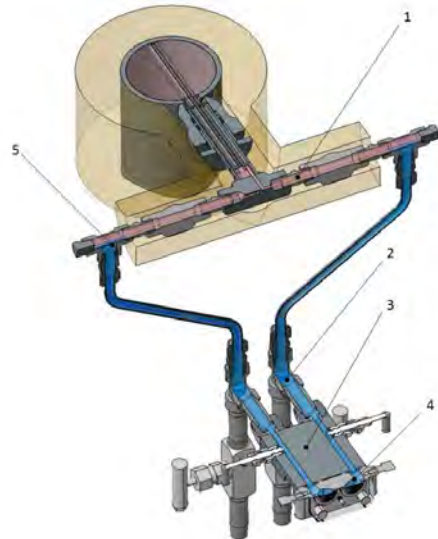
legs using the equalizer valve, which ensures an accurate measurement. If the DP transmitter zero is going to be checked, only the manifold isolation valves need to be closed.

**Figure 6.11: Averaging pitot tube in steam service for a vertical pipe.**



1. Vertical Steam Pipe
2. Pipe Insulation
3. Vertical Mount Averaging Pitot Tube Sensor

**Figure 6.12: Cross section of an averaging pitot tube for steam applications in a vertical pipe.**



1. Steam Vapor Impulse Piping
2. Condensate Impulse Piping
3. DP Manifold
4. DP Transmitter Diaphragm
5. Phase Change Point

### 6.3.5 The Integrally Mounted DP Flow Meter

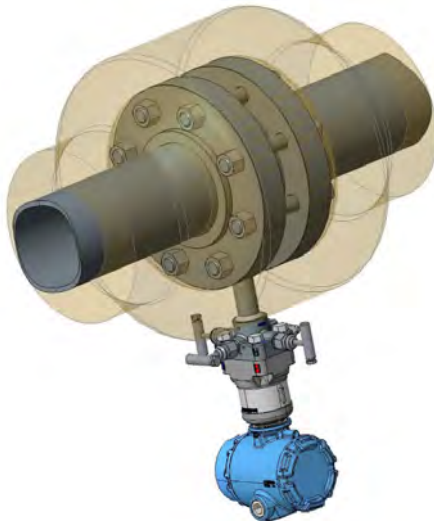
For many years, DP flow meters were assembled as shown in the previous figures. The labor and components required drove the development of new DP flow meters that would reduce the number of parts required, thereby reducing cost and labor. [Figure 6.13](#) and [Figure 6.14](#) show a newer style of an averaging pitot tube flow meter for steam service using an integrated DP transmitter and primary element. Due to the meter orientation, condensate fills the passages in the DP transmitter, manifold, and lower sensor, eliminating the need for large root valves and impulse piping.

The DP transmitter can also be ordered as a flow meter, which can be configured to read the temperature and/or pressure. This configuration will continually compensate for the steam properties for the calculated flow rate.

Figure 6.13: Integral averaging pitot tube flow meter.



Figure 6.14: Another image of an integrally mounted Conditioning Orifice Plate flow meter for steam applications.



### 6.4 Options for DP Transmitter Connections

The system piping arrangements shown in the preceding diagrams are typical for the steam service installations covered. It is not necessary to use valves and piping in the exact arrangement shown. While blow-down valves are convenient, they may not be required depending on the nature of the steam. The use of root valves may also not be required if a different type of valve is desired, and if it is a large port valve and meets the pressure and temperature requirements.

Another important consideration is whether to use threaded or socket-welded connections. Threaded connections are convenient and may be quicker to assemble, but they may loosen as the system comes to temperature and require a high temperature piping thread compound to seal the joint. Any leaks in the impulse piping system will compromise the DP signal and induce measurement error. It is imperative that any leaks be repaired before using the system. Socket-weld connections eliminate these issues and will provide longer maintenance-free installation with the disadvantage that any modification may require cutting the system apart.

### 6.5 Maintaining Wet Legs

As shown in the previous figures, the condensate levels in the high- and low-pressure sections of the DP primary element or impulse piping need to be at the same vertical level to eliminate errors caused by different head pressures of the liquid levels. The condensate level is controlled by maintaining temperature on both sides of the DP system and proper system orientation. Following the installation guidelines in the reference manuals or [Chapter 10](#) will help to ensure a successful installation.

## 6.6 Saturated Steam Applications

### 6.6.1 Process Heating

#### Primary Function of Application

Saturated steam is a principle energy source for process heating, component separation, motive power, and reactions. See [Figure 6.15](#). It is a preferred source because it is non-toxic, carries a high heat capacity, is efficient, and has low production costs compared to other energy transport systems. DP flow meters are ideal for making this measurement due to the flexibility and reliability of the primary element technologies and the ability to add measurement points wirelessly.

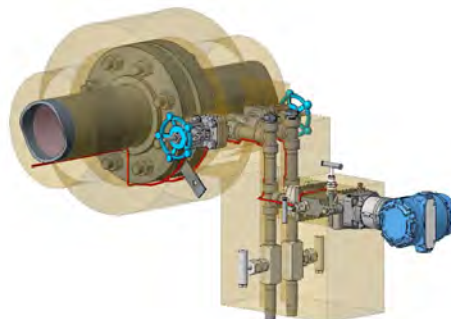
**Figure 6.15: A process heat application.**



#### Application Characteristics and Challenges

- Installations may be outdoors, which present a risk of impulse lines freezing. Integrated flow meters reduce the need to heat trace and improve overall cost of operation. See [Figure 6.16](#).
- Steam pressure may drop over long pipe distances; using a compensated flow measurement ensures fluid property changes are included in the calculation.

**Figure 6.16: DP flow meters may require heat tracing, shown in the red lines, to prevent the impulse lines from freezing. This is typically done on outdoor installations.**



#### Suitable Technologies

Rosemount Technology	Installation Guidelines
Annubar Averaging Pitot Tube	10.4.1, 10.5.2, 10.7.2
Traditional or Conditioning Orifice	10.4.2 - 10.4.4, 10.5.3, 10.5.4, 10.7.3
MultiVariable Transmitter	8.10, 10.3.3, 10.7.4

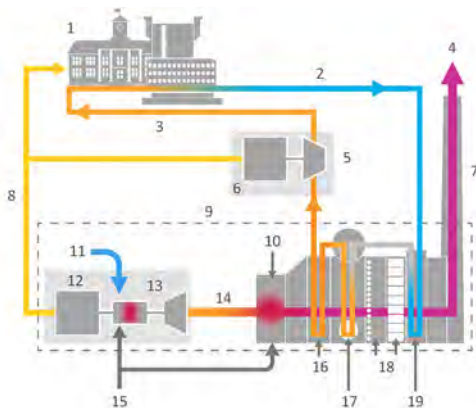
### 6.6.2 District Heating

#### Primary Function of Application

Many colleges, hospitals, and circumscribed commercial areas, such as downtown locations, take advantage of district heating. District heating plants offer higher overall efficiency and better pollution control than localized boilers. Since district heating steam is increasingly produced at cogeneration plants, combining centralized heat and power generation is often the most cost-effective means for cutting carbon footprint. See [Figure 6.17](#) for a diagram of a district heating system.

The large footprint for a district heating distribution system can lead to prohibitively high wiring costs when adding measurement points to the system. Wireless technology can be applied to remote locations in order to reduce or eliminate the costs of wiring.

**Figure 6.17:** A schematic diagram of a district heating distribution system.



- |                                   |                        |
|-----------------------------------|------------------------|
| 1. Campus Buildings               | 11. Air                |
| 2. Condensate from Campus         | 12. Generator          |
| 3. Low-Pressure Steam to Campus   | 13. Gas Turbine        |
| 4. Exhaust                        | 14. Hot Exhaust        |
| 5. Steam Turbine                  | 15. Natural Gas Fuel   |
| 6. Generator                      | 16. Superheater        |
| 7. Stack                          | 17. Steam Generator    |
| 8. Power to Campus                | 18. Emissions Controls |
| 9. High-Pressure Steam to Turbine | 19. Economizer Catcher |
| 10. Duct Burner                   |                        |

### Application Characteristics and Challenges

- Measuring steam distribution is important for load balancing and leak identification; flow metering accomplishes this.
- For commercial applications, accurate measurement is important for billing.
- Measurement points are often located a significant distance from the central plant and may be located underground.

### Suitable Technologies

Rosemount Technology	Installation Guidelines
Annubar Averaging Pitot Tube	10.4.1, 10.5.2, 10.7.2
Traditional or Conditioning Orifice	10.4.2 - 10.4.4, 10.5.3, 10.5.4, 10.7.3
MultiVariable Transmitter	8.10, 10.3.3, 10.7.4

### 6.6.3 Pulp and Paper

#### Primary Function of Application

Paper and paperboard production accounts for a significant percentage of manufacturing energy use in the U.S. About 40 percent of that fraction is used for production of steam, which is used to heat chemical baths for pulping, pre-steaming chips, and digester cooking. An example of steam usage in a pulp and paper mill is steam for paper drying on the dry end of the paper machine. See [Figure 6.18](#).

**Figure 6.18:** A paper machine within a pulp and paper mill.



### Application Characteristics and Challenges

- Pulp and paper mills require tight control over steam flows for efficient production.
- For companies who obtain steam from suppliers or use business unit-to-unit internal billing, accurate flow metering is essential to ensure billing consistency.

### Suitable Technologies

Rosemount Technology	Installation Guidelines
Annubar Averaging Pitot Tube	10.4.1, 10.5.2, 10.7.2
Traditional or Conditioning Orifice	10.4.2 - 10.4.4, 10.5.3, 10.5.4, 10.7.3
MultiVariable Transmitter	8.10, 10.3.3, 10.7.4

## 6.7 Superheated Steam Applications

### 6.7.1 Thermal Power Plants

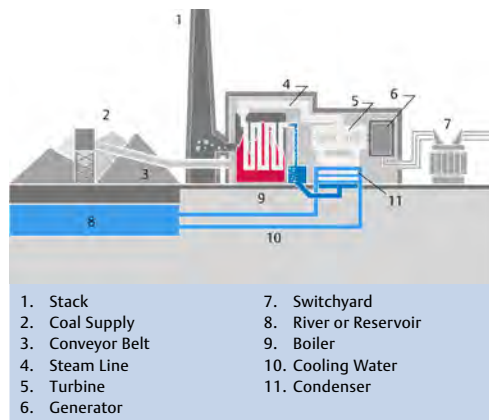
#### *Primary Function of Application*

Thermal power plants are power generation facilities that use heat to generate electricity. Typically this involves producing superheated steam to turn a turbine, which turns thermal energy into mechanical energy. This energy can then be used to drive a generator and produce electricity. Examples of thermal power plants include fossil-fuel powered (such as coal or natural gas), nuclear, geothermal, and concentrated solar. See [Figure 6.19](#) for a diagram of coal-fired electricity-generating plant.

Many industrial users also choose to generate electricity from the steam they create for their process. This is typically achieved using a combined heat and power plant. The electricity created can be used in the process or sometimes sold back to the electricity utility.

In all of these examples, steam is generated and delivered to the turbine at high pressures and temperatures, which can exceed 3000 psig (205 Bars-gauge) and 1100 °F (593 °C) with velocities up to 200 ft/sec (61 m/sec). These conditions require specialized metallurgies and carefully engineered flow meter components to prevent failure and damage.

**Figure 6.19:** Diagram of a coal-fired electricity-generating plant.



#### *Application Characteristics and Challenges*

- High temperatures and velocities require careful consideration of material choices and instrument design.

#### *Suitable Technologies*

Rosemount Technology	Installation Guidelines
Annubar Averaging Pitot Tube	<a href="#">10.4.1</a> , <a href="#">10.5.2</a> , <a href="#">10.7.2</a>
MultiVariable Transmitter	<a href="#">8.10</a> , <a href="#">10.3.3</a> , <a href="#">10.7.4</a>

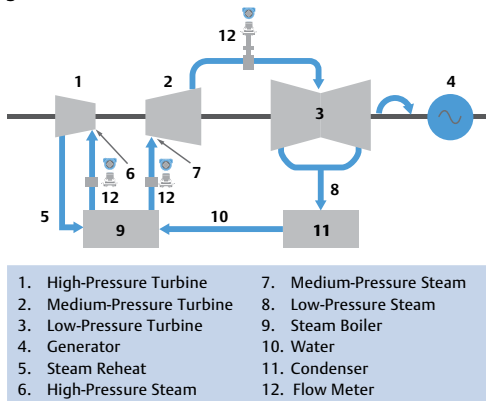
### 6.7.2 Turbine Steam Flow

#### *Primary Function of Application*

The primary function of a steam turbine is to convert thermal energy to rotational motion by allowing high-pressure steam to expand through the various stages of the turbine itself. Since steam is relatively safe, easy to handle, and well understood, it is by far the most common choice to drive turbines. However, some advanced designs, which explore supercritical CO<sub>2</sub>, are beginning to be used instead. The thermodynamic efficiency of turbines, which derives from multiple stages of steam expansion, is also relatively high.

DP flow technologies provide accurate and repeatable metering for turbines, with better accuracy than other inferred measurement methods (i.e., a method of estimating steam flow based on other turbine operational factors). Flow measurement is made on the main steam line for high-pressure turbines and on the reheat lines between the intermediate and low-pressure stages as shown in *Figure 6.20*.

**Figure 6.20: Flow diagram of a multi-stage steam turbine generator.**



### Application Characteristics and Challenges

- High temperatures and pressures require that the flow element be designed to withstand these conditions.
- Any chance of structural failure of the flow element must be eliminated to prevent damage of the turbine. Rosemount Annubar™ Averaging Pitot Tubes are specifically designed for this application.
- Minimal pressure loss should be specified to maintain overall efficiency.

### Suitable Technologies

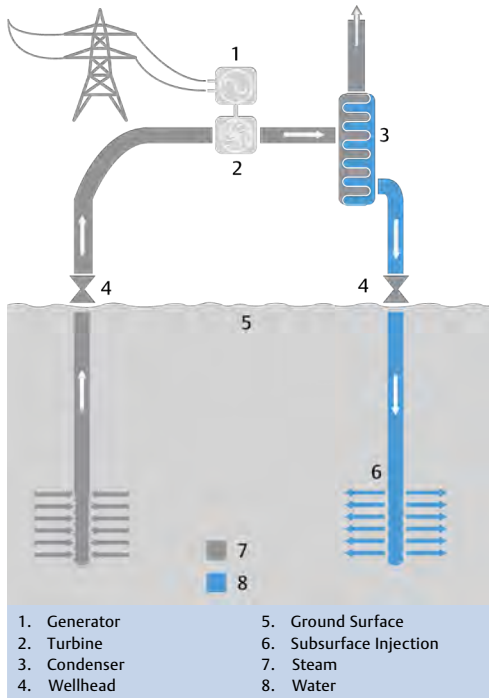
Rosemount Technology	Installation Guidelines
Main Steam Line Annubar Primary Element	Consult local Emerson representative
MultiVariable Transmitter	<a href="#">8.10</a> , <a href="#">10.3-3</a> , <a href="#">10.7.4</a>

### 6.7.3 Geothermal Energy

#### Primary Function of Application

Geothermal steam has similar applications to boiler-fed turbine installations, particularly for electric power generation. The distinction is that the heat of the earth's core is used to generate steam rather than combustible fuel sources. Steam generation can be direct via water injection into the geothermal hotspot. It can also be indirect where geothermally heated water in turn heats another vaporizable fluid in a steam generator, and the second fluid drives the turbine. See *Figure 6.21* for an example of a geothermal generating plant.

**Figure 6.21: Superheated steam produced at a geothermal generating plant.**



**Figure 6.22: Rosemount 3051SFA Annubar Flow Meter mounted above the pipe in a geothermal steam application.**



### Application Characteristics and Challenges

- Finding a good location for the instrumentation can be a challenge due to large distances between the instrument and the central control facility. Wireless instrumentation such as DP flow meters can significantly reduce the cost of installation in these locations.
- Periodic maintenance including intermittent purging may be necessary, particularly in direct geothermal heating, since the water can carry chemicals, minerals, and particulates from the source. Specialized designs can accommodate this need.
- For critical measurement points where shutdown must be avoided, hot tap averaging pitot tube flow meters could be used.

### Suitable Technologies

Rosemount Technology	Installation Guidelines
Annubar Averaging Pitot Tube	10.4.1, 10.5.2, 10.7.2
MultiVariable Transmitter	8.10, 10.3.3, 10.7.4

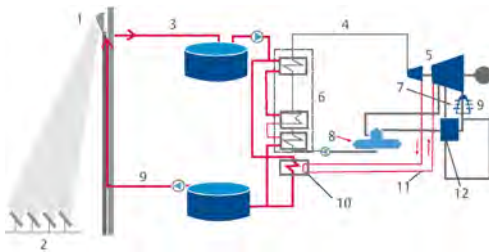
### 6.7.4 Concentrated Solar Energy

#### Primary Function of Application

Advances in the efficiencies and costs of concentrated solar thermal power technologies are making this energy source an attractive option. Sunlight concentrated by shaped mirrors or heliostats is focused on a boiler tower. See [Figure 6.23](#). In this tower, water is either converted directly to steam or molten salt is heated and then used to generate steam.

Main steam lines in these plants can operate at temperatures and pressures similar to traditional coal or gas-fired plants. Similar consideration must be taken into account when selecting the appropriate meter for the application.

**Figure 6.23: Diagram of routing and heat in a concentrated solar power facility.**



- |                                 |                                |
|---------------------------------|--------------------------------|
| 1. Solar Receiver               | 7. Air Cooled Condenser        |
| 2. Heliostat Field              | 8. Deaerator                   |
| 3. High Temperature Molten Salt | 9. Low Temperature Molten Salt |
| 4. High-Pressure Steam          | 10. Reheater                   |
| 5. Steam Turbine                | 11. Reheat Steam               |
| 6. Steam Generator              | 12. Preheater                  |

### Application Characteristics and Challenges

- High temperatures and pressures require a flow element that can withstand these conditions.
- Any chance of structural failure of the flow element must be eliminated to prevent damage to the turbine. Annubar Averaging Pitot Tubes are specifically designed for this application.
- Minimum permanent pressure loss should be specified to maintain overall efficiency.

### Suitable Technologies

Rosemount Technology	Installation Guidelines
Annubar Averaging Pitot Tube	10.4.1, 10.5.2, 10.7.2
MultiVariable Transmitter	8.10, 10.3.3, 10.7.4

## 6.8 Wet (Quality) Steam Applications

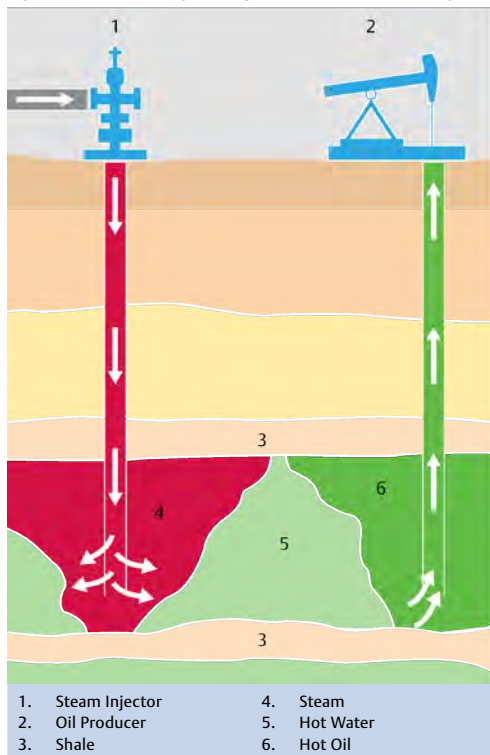
### 6.8.1 Steam Injection for Enhanced Oil Recovery

#### Primary Function of Application

Steam injection is widely used as an enhanced oil recovery method for extracting heavy crude oil. See [Figure 6.24](#). The hydrocarbons in oil reservoirs are highly viscous at the ground temperature of oil formations. The heat energy of steam lowers the viscosity, making pumping and flow easier. There are two primary approaches: cyclic steam stimulation, which includes steam injection followed by soak periods, and steam flooding, which is continuous.



Figure 6.24: Steam injection for enhanced oil recovery.



### Suitable Technologies

Rosemount Technology	Installation Guidelines
Annubar Averaging Pitot Tube	10.4.1, 10.5.2, 10.7.2
Traditional or Conditioning Orifice	10.4.2 - 10.4.4, 10.5.3, 10.5.4, 10.7.3
MultiVariable Transmitter	8.10, 10.3.3, 10.7.4

## 6.9 Applicable Flow Meter Standards

There are some published standards for flow meters:

1. *Properties of Saturated and Superheated Steam in U.S. Customary and SI Units from the IAPWS-IF97 International Standard for Industrial Use*, American Society for Mechanical Engineers, June 2006.
2. *Power Piping: ASME Code for Pressure Piping, B31 Code B31.1*, American Society for Mechanical Engineers, 2016.

### Application Characteristics and Challenges

- Locating the measurement point can be critical. It is important to enclose the steam point to maintain the temperature. Periodic purging and/or cleaning may be necessary.
- In cyclic applications, cold piping can produce sections of the pipe where large volumes of condensate, called water slugs, collect in the pipe. This can create problems for steam flow meters reading correctly until the system comes to temperature.





## Primary Element Technologies

	<b>Topic</b>	<b>Page</b>
7.1	Introduction	116
7.2	DP Primary Element Technology Types	116
7.3	DP Flow Meter Selection	117
7.4	DP Flow Primary Meter Design & Technology	127
7.5	Applicable Flow Meter Standards	146
7.6	Additional Information	146

## 7.1 Introduction

The differential pressure (DP) flow meter is made up of two distinct components: the primary element that is installed in the pipe and the secondary device that reads the DP signal. This chapter covers primary elements; see [Chapter 8](#) for secondary devices. Primary elements can be separated into two categories:

1. Area meters (i.e., static pressure meters)
2. Sampling meters (i.e., dynamic pressure meters)

The sizing, installation, configuration, and use of DP devices can be grouped into these two types in order to simplify the concepts.

These are the six DP primary elements that are discussed in this chapter:

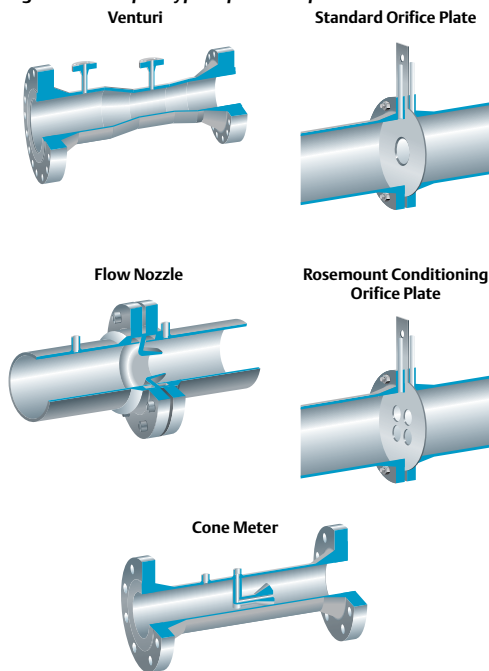
1. Orifice plate
2. Venturi tube
3. Flow nozzle
4. Wedge primary element
5. Cone meter
6. Averaging pitot tube

## 7.2 DP Primary Element Technology Types

### 7.2.1 Area DP Meter

The area DP meter is any device that uses the differential pressure flow equation where a change in the area of the flowing conduit is used to generate a difference in two static pressures. The first five types of DP devices are area meters, and they are shown in [Figure 7.1](#).

**Figure 7.1: The five types of area DP flow elements.**



The oldest design goes back to 1881 and the latest designs to 1976. In the more than 100 years of modern DP flow meter history, many variations have been introduced for the most popular of these primary designs. This was done to solve specific flow metering applications, reduce costs, simplify installation, and improve on performance. However, all area meters function the same way by measuring the pipe static pressure difference before and after the area reduction to determine the flow rate. This simple concept hasn't changed in more than 100 years.

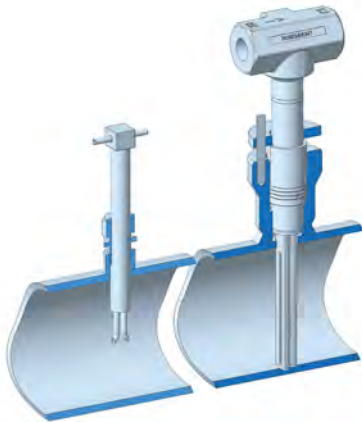
### 7.2.2 Sampling DP Meter

The other type of DP primary is a sampling meter, which is a pitot tube or averaging pitot tube. Both of these work the same by sampling the flow field in a pipe cross section to obtain the flow rate. [Figure 7.2](#) shows both devices mounted in a pipe. The difference between these two devices is that the pitot tube samples a point velocity and is physically moved by a technician

while data is collected, whereas the averaging pitot tube is fixed in the pipe and samples the velocity on a diameter continuously. Both devices measure the dynamic pressure, which is the pressure due to the velocity of the fluid. The pitot tube can be used to survey a potential flow meter location and typically is used to measure two or more axes at the measurement location. The averaging pitot tube is designed to be permanently mounted and is constructed for industrial flow meter applications.

While the area meter has a built-in flowing area, which is called the throat, the averaging pitot tube relies on the pipe area as the meter throat. The fluid goes through the area meter, but it goes around the averaging pitot tube. This provides a much lower pressure loss for the averaging pitot tube, but it does not allow sizing of the DP signal, which can be done with the area meter.

**Figure 7.2: The pitot tube and the averaging pitot tube.**



### 7.2.3 Non-Proprietary and Proprietary DP Flow Meters

Non-proprietary DP flow primary elements are those that have a design and specification standard that are in the public domain. They include the information required to size, fabricate, and install the meter, and they can be used without a concern for patent infringement. Most

of the original area meter designs fall into this category. Some device designs are no longer under patent.

Proprietary DP flow primary elements are typically exclusive to a manufacturer and are under patent protection and/or the name of the device is under copyright. Although intellectual property protection varies by world area, for countries where it does apply, these devices cannot be duplicated without permission or license agreement. Most averaging pitot tube devices as well as the latest orifice plate technologies, such as the Conditioning Orifice Plate, fall into this category. The manufacturer must be the reliable source of information for sizing, installation, and use of these devices.

## 7.3 DP Flow Meter Selection

The plethora of DP primary element designs is best reviewed by organizing the basic performance and installation characteristics into a selection table, which is shown in [Table 7.1](#). There are five primary design considerations when selecting a flow meter shown here:

1. Installation (i.e., pipe size and straight run)
2. Fluid type
3. Pressure and temperature
4. Performance
5. Costs

Once the concerns for these parameters are addressed, the guide can be used to determine the best primary element for an application. In many cases, DP primary elements can be custom designed and applied to non-standard applications even though they are shown in [Table 7.1](#) as “Not Designed for.”

# 7 - Primary Element Technologies

Table 7.1: The DP primary element selection guide.

Primary Element Types	Installation			Fluid Types									Pressure & Temperature			Performance				Costs						
	Small Pipes < 2 in. (50 mm)	Medium Pipes 2 - 12 in. (50 - 300 mm)	Large Pipes > 12 in. (300 mm)	Short Straight Run	Clean Liquids and Gases	Dirty Liquids and Gases	Steam Flow	High Viscosity	Wet Gas	Cryogenic	Low Flow	Corrosive	Fibrous Slurries	Abrasive Slurries	600 lb ANSI Pressure Rating	High Pressure >600 lb ANSI	High Temperature and Noble Alloys	Uncalibrated Uncertainty	Calibrated Uncertainty	Repeatability	Permanent Pressure Loss <sup>1</sup>	Rangeability <sup>1</sup>	Purchase	Installation	Operating	
<b>Orifice Plates</b>																										
Concentric	Green	Green	Green	Orange	Green	Orange	Green	Orange	Green	Blue	Blue	Blue	Orange	Orange	Green	Blue	Blue	Green	Green	Blue	Blue	Blue	\$	\$	\$	\$
Eccentric	Orange	Green	Orange	Orange	Green	Orange	Green	Orange	Blue	Blue	Blue	Blue	Orange	Orange	Green	Blue	Blue	Green	Green	Blue	Blue	Blue	\$	\$	\$	\$
Segmented	Orange	Green	Orange	Orange	Green	Orange	Green	Orange	Blue	Blue	Blue	Blue	Orange	Orange	Green	Blue	Blue	Green	Green	Blue	Blue	Blue	\$	\$	\$	\$
Quadrant-Edge	Orange	Green	Orange	Orange	Green	Orange	Green	Orange	Blue	Blue	Blue	Blue	Orange	Orange	Green	Blue	Blue	Green	Green	Blue	Blue	Blue	\$	\$	\$	\$
Conical	Orange	Green	Orange	Orange	Green	Orange	Green	Orange	Blue	Blue	Blue	Blue	Orange	Orange	Green	Blue	Blue	Green	Green	Blue	Blue	Blue	\$	\$	\$	\$
Conditioning	Orange	Green	Green	Green	Green	Orange	Green	Orange	Green	Blue	Blue	Blue	Orange	Orange	Green	Blue	Blue	Green	Green	Blue	Blue	Blue	\$	\$	\$	\$
<b>Other Meters</b>																										
Venturi	Orange	Green	Green	Orange	Green	Green	Green	Blue	Green	Blue	Blue	Blue	Blue	Green	Blue	Blue	Green	Green	Blue	Green	Green	\$\$\$	\$	\$	\$	
Nozzle	Green	Blue	Blue	Orange	Green	Blue	Orange	Green	Blue	Blue	Blue	Blue	Orange	Green	Blue	Blue	Green	Green	Blue	Blue	Green	\$\$\$	\$	\$	\$	
Cone Meter	Orange	Green	Blue	Blue	Green	Green	Blue	Green	Green	Blue	Blue	Blue	Blue	Green	Blue	Blue	Orange	Green	Green	Blue	Green	\$\$\$	\$	\$	\$	
Wedge Meter	Orange	Blue	Blue	Orange	Green	Orange	Green	Orange	Blue	Green	Blue	Green	Green	Green	Blue	Blue	Blue	Orange	Green	Blue	Green	\$\$\$	\$	\$	\$	
Averaging Pitot Tube	Orange	Green	Blue	Orange	Green	Orange	Green	Orange	Blue	Orange	Blue	Orange	Orange	Green	Blue	Blue	Blue	Green	Blue	Green	Blue	\$	\$	\$	\$	

**LEGEND**

- Designed for
- Normally Applicable
- Not Designed for

<sup>1</sup> Depends on application

### 7.3.1 Installation

The primary concern for installation when selecting a flow meter is the size of the pipe. Most meter designs have a range of pipe size that the device is designed for and will include calibration data that confirms performance. Many devices can be used outside this range, but the user must assume responsibility for proper use and performance unless a calibration is done. Pipe sizes for DP primary elements can be broken down into three ranges, which are shown in [Table 7.2](#):

- Small: < 2 in. (50 mm)
- Medium: 2 - 12 in. (50 - 300 mm)
- Large: > 12 in. (300 mm)

The application differences for the different pipe size ranges are shown in [Table 7.2](#). More information on installation is covered in [Section 7.3.5](#).

### 7.3.2 Fluid Types

There are many types of industrial fluids where the flow rate needs to be metered. For DP flow meter applications, these fluids can be put into six categories:

1. Clean liquids and gases — air, nitrogen, oxygen, water, natural gas, light oils, etc.
2. Steam flow — saturated and superheated
3. Dirty liquids — river water, treated sewage, process waste water, etc.
4. Dirty gases — flue or stack gas
5. High viscosity > 10 centipoise — medium to heavy crude oil, motor oils, syrups, etc.
6. Wet gases with a Lockhart-Martinelli number of  $\leq 0.30$  — upstream gas well output and wet steam

Other specific fluid types are included in [Table 8.1](#). The suitability of each type of DP meter to these fluid types is dependent on the basic flow meter design and the options that are available to augment the standard application range. For example:

- Wedge primary elements combined with DP transmitters can be used for the most dirty, high-viscosity, and fibrous-laden liquids.

**Table 7.2: Differences in DP primary element pipe size ranges.**

Application Category	Small Diameter < 2 in. (50 mm)	Medium 2 in. < D < 12 in. (50 - 300 mm)	Large Diameter > 12 in. (300 mm)
Availability	Many types for industrial and HVAC	Most all designs available	Most area meters limited to 30 in. (760 mm)
Calibration	Easily calibrated	Most can be calibrated	Limited and can be expensive
Installation	Simple	Large Venturis and spool meters require planning	More complicated and can be expensive
Maintenance	Easy; piping can be arranged for isolation of meter	Requires planning; plates and averaging pitot tubes can be hot removeable	May need to be done during shut down of pipe

- The eccentric, segmental, and Conditioning Orifice Plates work well with wet gases, provided the installation is done to prevent liquids from accumulating in the DP transmitter.
- The quadrant-edged orifice plate works well for higher viscosity liquids, provided that the viscosity is low enough that the impulse piping to the DP transmitter can be bled of air.

given a pressure/temperature rating that complies with ANSI or DIN flange ratings. Relatively high and low temperatures also need design considerations and may require custom materials. Many of the specialty alloys commonly used for more extreme working temperatures are available for most of the DP flow meter designs covered here. See [Table 7.1](#) for more information. Special designs for flow meters can be accommodated by flow meter manufacturers.







### 7.3.3 Pressure and Temperature Requirements

Elevated pressures require specific design accommodations as DP flow meters are exposed to the working pipeline pressure. The meters are required to meet the piping practices used in a local plant or facility. Typically, a flow meter is

### 7.3.4 Flow Meter Performance Review

After the initial meter size, fluid type, and pressure/temperature requirements are reviewed, flow meter performance is the next concern to address. [Table 7.3](#) shows a relative measure of these performance parameters for DP primary elements. While many applications do not require

**Table 7.3: Performance for DP flow primaries elements.**

Performance Parameter	Process Fluid	Meter Type					
		Venturi Tube	Orifice Plate	Flow Nozzle	Cone Meter	Wedge Meter	Averaging Pitot Tube
							
Linearity	Liquid	Best	Good	Good	Best	Best	Best
	Gas	Best	Best	Best	Best	Best	Best
	Steam	Best	Best	Best	Best	Best	Best
Accuracy Uncalibrated	Liquid	Best	Best	Best	Good	Good	Best
	Gas	Best	Best	Best	Good	Good	Best
	Steam	Best	Best	Best	Good	Good	Best
Accuracy Calibrated	Liquid	Best	Best	Best	Best	Best	Best
	Gas	Best	Best	Best	Best	Best	Best
	Steam	Best	Best	Best	Best	Best	Best
Turndown	Liquid	Best	Best	Best	Best	Best	Best
	Gas	Best	Best	Best	Best	Best	Good
	Steam	Best	Best	Best	Best	Best	Good

#### LEGEND

- Best Application
- Good Application
- Could Be Limiting



absolute accuracy, it is used as a deciding factor when evaluating flow meters. In addition to accuracy, there are several additional performance parameters that should be considered.

### 7.3.4.1 Repeatability

Repeatability is defined as the closeness in agreement of successive measurements for the same meter, operator, application, and conditions. For any instrument, repeatability is the primary performance parameter as it is the basis for measurement. It also represents the smallest possible error for an instrument—the repeatability value is the best performance an instrument can provide. For a flow meter, this parameter is affected by the flowing conditions and the method for reading the DP flow signal. Values given in flow meter literature are typical for a clean installation with a DP transmitter. Pulsating flow, turbulence due to upstream fittings, and the inherent noise of the meter signal all affect repeatability.

### 7.3.4.2 Linearity

Linearity is defined as the maximum change in meter performance over a given flow rate range. For a DP flow meter, linearity represents the largest error in meter output over the Reynolds number range for the same fluid conditions. For DP flow meters with a changing discharge coefficient such as an orifice plate, the measure of error due to linearity will become larger as the flow is reduced if this change is not compensated for in the flow calculation. This is covered in [Section 7.3.4.3](#).

### 7.3.4.3 Accuracy

Accuracy is defined as the closeness of agreement of the meter reading to a known value. This performance parameter is often used as an overarching measure of the usefulness of an instrument. By definition, accuracy is a sub-component of the more scientific term uncertainty<sup>1</sup>, defined in the simplest form as:

$$U(t) = t \sqrt{u_A^2 + u_B^2}$$

Where:

- $U$  Expanded uncertainty and given at the coverage factor,  $t$
- $t$  Coverage factor, which is determined from the student's t-distribution and depends on the number of data points and the desired percent of coverage. For a sample data set of 30 or more data points, the value of  $t$  is 1 (67% coverage), 2 (95% coverage), or 3 (99% coverage)
- $u_A$  Standard uncertainty for all of the random or Type A sources of error used to obtain the expanded uncertainty of the instrument
- $u_B$  Standard uncertainty for all of the systematic or Type B sources of error used to obtain the expanded uncertainty; this component includes the traceability errors back to the known calibration reference, which is traditionally the accuracy component

While this discussion is not an extensive look at uncertainty, an important part of the determination of uncertainty is defining the sensitivity factors for each source of error. A sensitivity factor is a measure of the impact an error for a particular parameter has on the calculated value. [Tables 7.4](#) and [7.5](#) show the parameters that are needed to calculate the flow rate and the sensitivity factors for an orifice plate and an Annubar Averaging Pitot Tube. For an orifice plate, the sensitivity changes with the bore/pipe diameter ratio.

**Table 7.4: Sensitivity factors for an orifice plate.**

Parameter	Symbol	Sensitivity Factor
Orifice Bore	$d$	$\frac{2}{1 - \beta^4}$
Discharge Coefficient	$C_d$	1
Pipe Inside Diameter	$D$	$\frac{2\beta^4}{1 - \beta^4}$
Fluid Density	$\rho$	-0.5
Primary Element DP	$\Delta P$	0.5

<sup>1</sup>This is a simple look at uncertainty. There are many methods for calculating uncertainty. Also, some sources do not equate all random error sources to Type A and all systematic error sources to Type B as is done here.

**Table 7.5: Sensitivity coefficients for an Annubar Averaging Pitot Tube.**

Parameter	Symbol	Sensitivity Factor
Flow Coefficient	$K$	1
Pipe Inside Diameter	$D$	2
Fluid Density	$\rho$	-0.5
Primary Element DP	$\Delta P$	0.5

Accuracy is not a scientific term. When reviewing flow meter performance specifications, the definition of the term should be reviewed. In some cases, accuracy becomes a catch-all parameter that includes other performance values such as linearity, repeatability, and hysteresis, and in this case, it should be called the composite accuracy.

### 7.3.4.4 Reproducibility

Reproducibility is defined as the statistical change in results for a meter used in different conditions, applications, or operators. This term can also be defined to include the additional uncertainty in results for multiple meters of the same size and type tested under similar conditions. If there is a calibration for the meter, the results will be used to configure the meter. Although small, there will always be a difference between the actual or field performance and the typical rated performance. This is the reproducibility. For an uncalibrated meter, the value for reproducibility will be larger as it must include the tolerances of the meter manufacturing process. Reproducibility may be included in the accuracy statement, and in some cases, there is a calibrated and uncalibrated meter accuracy given for this reason.

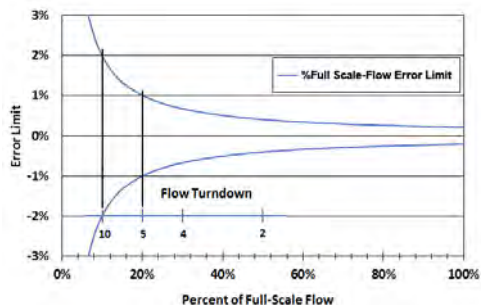
### 7.3.4.5 Turndown

Turndown is defined as the ratio of the highest over the lowest flow rate that can be read within the stated flow meter performance. Flow meter turndown has become an important second performance measure after accuracy when comparing flow meter technologies based on performance alone. For flow meters, it is listed as

a ratio X:1, read X to 1, where X is the turndown. Turndown is dependent on the stated accuracy, repeatability, and meter linearity. For example, if the stated accuracy is  $\pm 2\%$ , the turndown may be 10:1. However, if that is reduced to  $\pm 1\%$ , the stated turndown will usually be lower, such as 5:1.

Figure 7.3 shows this graphically for a  $\pm 0.2\%$  of full-scale flow meter. It is also more complicated to determine the true flow turndown for a DP flow meter, as it should include the secondary DP device (i.e., transmitter) in the statement for the integrated flow meter. The DP transmitter has a separate accuracy and turndown statement that must be applied to the range of DP that is to be measured. Due to the relationship between the flow rate and DP, the DP turndown is the square of the flow turndown. Many flow meter configuration programs include a measure of turndown when configuring an application for both the primary element and DP transmitter. Turndown is greatly affected by the stated minimum flow rate. For example, if the turndown is 10:1 with a maximum flow rate of 1000 gal/min (3785 l/min), the low flow rate is 100 gal/min (757 l/min). If the low flow rate could be reduced 33% to 67 gal/min (277 l/min), the turndown would be 15:1, which is 50% greater.

**Figure 7.3: Accuracy vs. turndown.**



### 7.3.4.6 Flow Coefficient

The flow coefficient,  $K$ , is the parameter that characterizes the behavior of the flow meter that the Bernoulli equation does not account for, with the given geometry and the effects of a real fluid in a pipe. The magnitude of this value determines

the size of the DP signal for the given flow rate, and the change in this value over the operating range determines the linearity and turndown capability. To understand the flow coefficient, the DP flow meter equation must be reviewed. For an incompressible fluid flow, the DP mass flow equation for an area meter (modified from ISO 5167-2:2003) is:

$$Q_m = \frac{C}{\sqrt{1-\beta^4}} \varepsilon \frac{\pi}{4} d^2 \sqrt{2\Delta P g_c \rho_1}, \text{ where,}$$

in USC units (SI units):

$Q_m$  Mass flow rate,  $\frac{lb_m}{sec} (\frac{kg}{sec})$

$C$  Discharge coefficient, dimensionless

$\frac{1}{\sqrt{1-\beta^4}}$  Velocity of approach,  $E$ , dimensionless

$\varepsilon$  Expansibility factor, also called  $Y$ , dimensionless

$\frac{\pi}{4} \sqrt{2g_c}$  Numerical constant,  $N$ , which also includes conversions of units for  $Q_m$ ,  $d$ ,  $\Delta P$  and  $\rho$  if the base units shown here are not used

$d$  Single-bore diameter for area meter, ft (m)

$\Delta P$  Differential pressure,  $\frac{lb_f}{ft^2} (P_{ascals})$

$g_c$  Initial force conversion constant<sup>1</sup>,  
 $32.174 \frac{lb_m \cdot ft}{lb_f \cdot sec^2} (1 \frac{kg \cdot m}{N \cdot sec^2})$

$\rho_1$  Fluid density at upstream tap,  
 $\frac{lb_m}{ft^3} (kg/m^3)$

The same equation using the defined terms for incompressible flow ( $Y = 1$ ) is:

$$Q_m = N d^2 C E \sqrt{\Delta P \rho}$$

Noting that:  $d^2 = D^2 \beta^2$ , the equation becomes:

$$Q_m = N D^2 (\beta^2 C E) \sqrt{\Delta P \rho}$$

and for the averaging pitot tube is:

$$Q_m = N D^2 K \sqrt{\Delta P \rho}$$

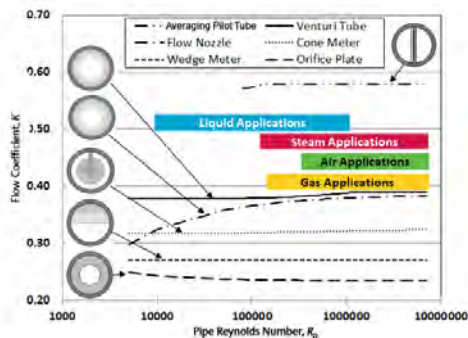
For an area meter, the flow coefficient,  $K = \beta^2 C E$ . The values  $\beta^2 E$  are the factors due to the area change which are constant for a given beta, and the discharge coefficient,  $C$ , accounts for the viscous losses and characterizes the flow primary as it changes over the range of measurement. For an averaging pitot tube, there is only the flow coefficient,  $K$ , which accounts for the area change and the viscous losses.

Grouping the parameters in these equations gives:

$$\text{Flow} = \text{Geometry} \times \text{Coefficient} \times \sqrt{\frac{\Delta P}{\text{Density}}}$$

Each of the terms on the right side of the equation contribute to the calculated flow rate. When comparing the performance of different area DP meters, the common parameters (i.e., geometry and density) are set to the same value so the differences can be easily seen. Figure 7.4 shows the flow coefficient for the six devices based on a 6-in. (150 mm) pipe size and an area meter bore/pipe diameter or beta of 0.60. The DP generated for the same application will be greatest for the orifice meter and least for the averaging pitot tube. The wedge primary element has the best linearity over the widest flow rate range.

**Figure 7.4: Flow coefficient for the six DP flow primary elements for a beta of 0.60 in a 6-in. (150 mm) pipe.**



For liquid applications, the range extends over pipe Reynolds numbers ( $Re_D$ ) that show changing discharge coefficients for the orifice plate and flow nozzle. If turndown is the primary performance

<sup>1</sup>The parameter,  $G_c$ , is left out of many references on flow measurement, including 5167-2:2003. It has been included in this equation. See Chapter 3 for more information.

parameter, it is important to size the primary element and/or use a flow meter with a feature that will compensate for the changing discharge coefficient. Gas and steam applications extend into the linear range for all area meters. However, sizing is still recommended due to the lower DP signals.

Averaging pitot tubes have a linear flow coefficient and almost no Permanent Pressure Loss (PPL), but they generate less than half of the DP of an area meter. [Table 7.6](#) shows the typical DP values of a 6-in. (150 mm) pipe for the five area meters and the averaging pitot tube.

**Table 7.6: DP by meter type for a beta of 0.60 in a 6-in. (150 mm) pipe.**

Primary Element	Water: 68 °F (20 °C)	Gas: 300 psig (21 bar)	Saturated Steam: 100 psig (6.9 bar)
Fluid Velocity	8 ft/s (2.4 m/s)	65 ft/s (19.8 m/s)	100 ft/s (30 m/s)
Re(D)	463512	3021785	434564
Differential Pressure in inH <sub>2</sub> O (kPa)			
Venturi Tube	81 (20.3)	76 (18.9)	52 (13.1)
Orifice Plate	218 (54.4)	203 (50.8)	140 (35.1)
Flow Nozzle	85 (21.1)	79 (19.7)	54 (13.6)
Wedge Meter	163 (40.9)	152 (38.1)	105 (26.3)
Cone Meter	117 (29.2)	109 (27.2)	75 (18.8)
Averaging Pitot Tube	35 (8.9)	33 (8.3)	23 (5.7)

### 7.3.5 Installation Requirements

The selection criteria for a flow meter primarily involves the pipe size. However, how the meter installation will be made for the application must also be evaluated. The major considerations for DP flow meter installation are:

1. Straight piping requirements
2. Meter location and orientation
3. A new piping location (i.e., to be fabricated) or a retrofit installation
4. The total costs, which include purchase, installation, and maintenance costs

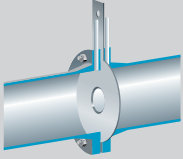
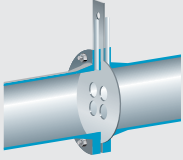
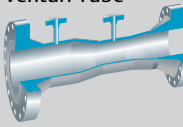
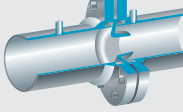
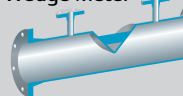
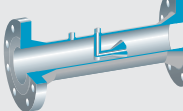

See [Chapter 10](#) for more information on installation.

#### 7.3.5.1 Straight Piping Requirements

All DP flow meters are velocity devices, where the differential pressure signal is generated primarily by the fluid velocity. The condition of the velocity upstream of the meter should be similar to how the meter was calibrated. When a velocity field is stable, meaning it doesn't change as the fluid travels down the pipe, it is said to be developed. Flow meters are calibrated in a test piping section that has developed velocity fields. Straight piping requirements for a DP flow primary element are developed and shown for the type of pipe fitting, or disturbance, that is immediately upstream of the meter. Some disturbances create a larger change in output than others, so the required straight piping to the meter is longer. From a fluid dynamic view, the parameter that dissipates turbulence is the fluid viscosity. For this reason, liquids tend to return the flow field to a developed state in a shorter distance than gases. However, most piping charts are used for all fluids.

[Table 7.7](#) provides straight piping requirements for the different DP primary elements installed downstream of a single pipe elbow. The amount of straight pipe lengths is given in terms of the number of pipe diameters. The two columns in the table show the required upstream and downstream lengths of straight pipe required for each meter type. Each technology will have a unique chart that shows the required lengths for several types of upstream pipe fittings or disturbances. For an averaging pitot tube, there are typically different lengths depending on the orientation of the sensor to the upstream fitting. For area DP meters, the requirement for straight pipe depends on the meter bore or beta ratio. See [Chapter 10](#) for more information.

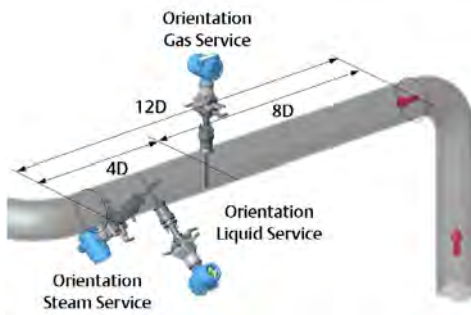
**Table 7.7: Straight pipe requirements for a single elbow upstream for various DP primary elements for a beta of 0.60.<sup>1</sup>**

DP Meter Type	Upstream Straight Pipe	Downstream Straight Pipe
Orifice Plate 	42	7
Multi-Hole Orifice Plate 	2	2
Venturi Tube 	10	5
Flow Nozzle 	18	7
Wedge Meter 	5	2
Cone Meter 	3	1
Averaging Pitot Tube 	8	4

### 7.3.5.2 Determining the Primary Meter Location and Orientation

The proper primary element location and orientation must be considered before installing a flow meter. The location is primarily determined by the straight pipe requirement, but it must also consider access to the meter for maintenance. The orientation is the location of the primary meter taps, or averaging pitot tube head, around the circumference of the measurement plane. For an averaging pitot tube, location and the proper orientation of the sensor in the pipe will affect the amount of straight pipe required. An example of flow meters installed in a pipe are shown in [Figure 7.5](#) for the three primary fluid types: gas, liquid, and steam, which all require a different orientation. Since the gas service meter is in plane with the upstream elbow, only eight pipe diameters are required. However, the liquid and steam meters are out of plane, so they require 12 pipe diameters.

**Figure 7.5: Flow meter location and orientation in a piping branch.**



### 7.3.5.3 New Installation or Retrofit

Consider whether a flow meter is needed for a new installation or a retrofit before deciding on the type of flow meter primary element. For a new installation, the flow meter can be designed into the piping. This provides an optimum installation

<sup>1</sup>The values for the pipe diameters are from ISO 5167 and manufacturers' documents.

with the least amount of effort. However, it is imperative that the group at the plant or facility in charge of piping, which is typically not the same as the one for instrumentation, understands the meter requirements for locating the mounting hardware and orders the proper hardware in time to be included in the fabrication.

For a retrofit installation, the primary concern is how the installation will be done for a system that is in use and under pressure. In most cases, this is done during a plant or system shutdown. In some cases, if a shutdown is not soon enough, an installation under pressure, or hot tap, can be made. Most averaging pitot tube manufacturers offer a solution that can be hot tapped using the proper equipment. See [Chapter 10](#) for more information about hot tapping.

### 7.3.5.4 Sizing an Area DP Flow Meter

Sizing an area DP flow meter is done when a specified DP range is desired for the given conditions and flow rate range. Some DP primary elements such as the orifice plate can have a selected bore precisely cut for a specific application. Once the conditions and required DP at normal or full scale flow are known, the sizing equations are used to determine the meter bore. For a volumetric flow rate:

$$Q_v = NCYd^2E\sqrt{\Delta P/\rho}$$

The equation can be rearranged to:

$$Q_v = ND^2CY\beta^2E\sqrt{\Delta P/\rho}$$

The terms  $CY\beta^2E$  are specific to the meter bore and are assigned to the term  $S_M$ . This is also the coefficient,  $K$ , that is mentioned in [Section 8.2.5](#), for the metering size factor. The equation is solved for the sizing factor:

$$S_M = \frac{Q_v}{ND^2\sqrt{\Delta P/\rho}}$$

The flow rate and desired DP for the given conditions are used to determine the meter sizing factor. The values for  $C_d$  and  $Y$  ( $Y$  for gases and vapors only) are flow-dependent, so an iterative solution is required for an exact match between flow rate and the desired DP. Once the bore

is determined, the area meter will provide the required range of DP for the application.

### 7.3.6 Costs

The total cost for operating a flow meter includes purchase, installation, operation, and maintenance costs. While there are obvious differences in the upfront costs of a flow meter, the total installed cost and overall lifetime cost should also be evaluated when making a technology decision.

#### 7.3.6.1 Purchased Costs

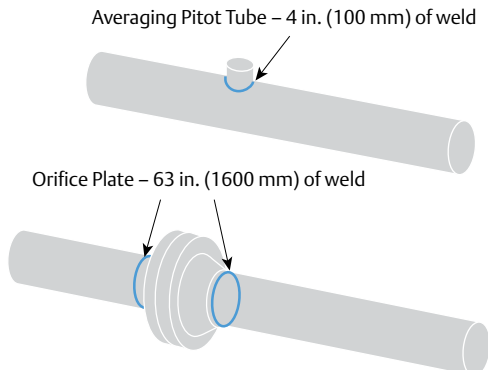
Purchased costs are the most obvious costs when selecting a flow meter. Spool meters, such as the Venturi, wedge primary elements, and cone-type meters, tend to be more expensive than other types. Also, although an orifice plate appears to be a relatively low-priced item, orifice meter flanges and the required associated impulse piping should be considered in the costs. The meter material needed will determine the final purchase cost. If special alloys are required, the overall cost can be much higher. It is also important to determine the type of DP or primary element that is required for the application. If the output of the transmitter must be proportional to flow rate, and/or if pressure or temperature compensation is required, a more expensive version of the transmitter will need to be purchased.

#### 7.3.6.2 Installation Costs

Installation costs are those associated with installing, connecting, and commissioning the DP flow meter. The type of installation (i.e., new or retrofit) will affect the installation costs. For a new installation, the fabrication crew is already on-site and the overall time required to install the meter is reduced. The costs for cutting, fit-up, and welding are affected by the type of DP flow meter installed. [Figure 7.6](#) compares the welding required for an averaging pitot tube vs. an orifice meter flange mounting for a 10-in. (250 mm) pipe.

Other installed costs such as running wiring, tubing, and connecting the meter signal to a control system must also be included.

**Figure 7.6: Welding required for orifice plate vs. averaging pitot tube.**

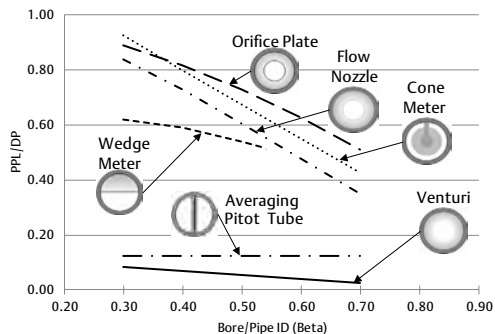


### 7.3.6.3 Operating and Maintenance Costs

Operating and maintenance costs are the final costs to consider when selecting a flow meter. In some cases, these costs are not considered when the meter is ordered as the plant design and fabrication may be done by a different company than the one who will operate the equipment. Operating costs primarily include the pressure loss associated with the flow meter and the required maintenance.

Permanent Pressure Loss (PPL) is incurred from the additional energy needed to pump or compress the fluid to overcome the loss in pressure due to the meter. If an area meter is used for a given application, the value for PPL is different for the type of meter and the bore size selected. In some applications, pressure-reducing valves may mask any PPL savings. *Figure 7.7* shows the relative PPL, which is the PPL divided by the meter DP, for the six DP primary elements. If pressure loss is of primary concern, a Venturi or averaging pitot tube can be used.

**Figure 7.7: Permanent Pressure Loss for DP primary elements.**



Maintenance of a flow meter includes periodic examination for wear and contamination as well as calibration if required. Systems are available for orifice plates and averaging pitot tube meters that enable the meter to be removed while the piping is under pressure. Some systems are designed for in-situ calibration, while others will require that the meter be removed and sent to a calibration facility. Flow meters that are removable under pressure provide a simple solution for maintenance. Although the initial purchase price is higher, maintenance is simplified over the life of the meter. The need to periodically check calibration will add to the cost of operation and estimates should be obtained before purchasing the meter.

## 7.4 DP Flow Primary Element Design and Technology

DP flow primary elements constitute a physical geometry that is inserted into a pipe to create a difference in two pressures as fluid flows through or around them. This difference can be used to calculate the flow rate. The suitability of a DP primary element to the application is determined during product development, and if used within these boundaries, will give consistent and accurate results.

### 7.4.1 Orifice Plates

Orifice plates are one of the oldest DP flow meter technologies and were first documented in Roman times. The first U.S. patent for the orifice plate was awarded to T.R. Weymouth in 1916. Orifice plates have remained popular because of their simplicity and the inherent scalability and repeatability of the flow through a sharp-edged orifice bore. This physical trait allowed the orifice to become a design type, which is a design where all important parameters are documented into a standard so that they can be reproduced to achieve the documented performance. Once a standard is published, data can be accumulated and analyzed so that the design equations used to calculate the discharge coefficient are improved. There are several orifice plate flow meter standards in use today:

1. ISO 5167-2:2003 Measurement of fluid flow by means of pressure differential devices inserted in circular-cross section conduits running full — Part 2: Orifice plates
2. ASME MFC-3M: Measurement of Fluid Flow in Pipes Using Orifice, Nozzle, and Venturi
3. ASME MFC-14M: Measurement of Fluid Flow Using Small Bore Precision Orifice Meters
4. AGA Report No. 3: Orifice Metering of Natural Gas and Other Related Hydrocarbon Fluids, Parts 1, 2, and 3, 2013
5. ISO/TR 15377:2018 Measurement of fluid flow by means of pressure-differential devices — Guidelines for the specification of orifice plates, nozzles and Venturi tubes beyond the scope of ISO 5167
6. GOST 8.586.1-2005: Measurement of Flowrate and Volume of Liquid and Gas by Means of Standard Pressure Differential Devices—Part 1. Principle of Method of Measurement and General Requirements

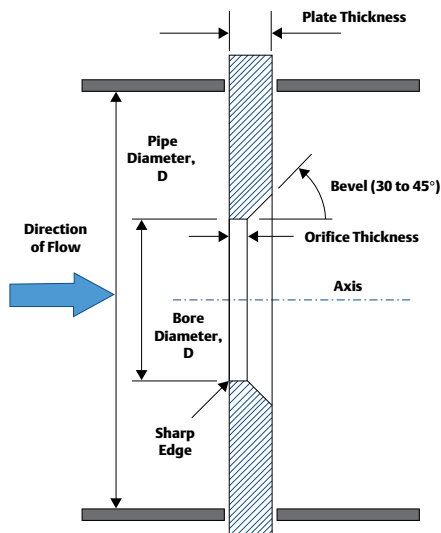
#### 7.4.1.1 Concentric Orifice Maker

The concentric sharp-edged orifice plate is considered the standard orifice plate design. This type of orifice plate is the most common and is used with one of several types of pressure taps. The primary design parameters for a concentric orifice plate are:

- Plate flatness, finish, and thickness
- Edge design and quality (i.e., sharpness)
- Concentricity of bore to the pipe
- Condition of the piping — roundness and inside wall roughness
- Location and design of the pressure taps

*Figure 7.8* shows the basic dimensions of a concentric, sharp-edged orifice plate. There are several types of taps, which are defined by the location of the tap centerline from the orifice plate face.

*Figure 7.8: The concentric, sharp-edged orifice plate.*



See *Figure 7.9* for the most common taps, which are:

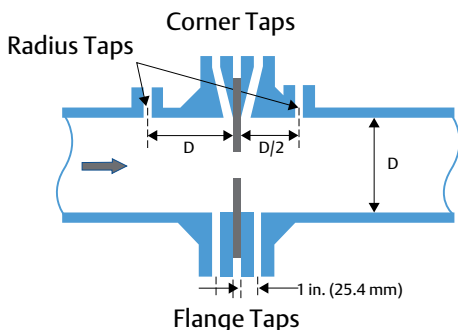
- Corner taps — The tap edge is at the orifice plate surface. They are typically used for



orifice plates in smaller diameter pipes where the small orifice bore would put the vena-contracta close to the plate. They are sometimes used with a pressure-averaging piezometer, which require more precision to machine.

- Radius taps (i.e., D, D/2 taps) — Upstream tap at one pipe diameter and downstream tap at ½ pipe diameter from the orifice plate surface. They can be installed without special flanges or machined mounting systems by welding couplings to the pipe wall at specified distances.
- Flange taps — Center of tap at 1 in. (25.4 mm) from the orifice plate surface. These are the most common tap type. The taps are machined into special orifice flanges, which must be included in the piping.

**Figure 7.9: The most common orifice meter taps.**



The sharp edge of the orifice bore has a required maximum radius of  $0.0004d$ , and the orifice thickness must be between  $0.005d$  and  $0.02d$ , which is provided by the bevel on the downstream face. This feature provides an unobstructed path for the flow as it exits the bore.

When orifice plates are made for pipe sizes smaller than 2 in. (50 mm), the design parameter tolerances are smaller, and only corner taps are used. Separate standards specify the fabrication and use of small-bore orifice plates. See ASME MFC-14M for more information.

Since a formal design for the orifice plate was established, there have been several equations developed to calculate the discharge coefficient,  $C$  (for the concentric, sharpened-edged orifice plate based on the results of many calibrations). These equations take into account the bore-to-pipe diameter ratio, or  $\beta$ , the tap location, and the pipe Reynolds number. The most recent equation used is the Reader-Harris Gallagher (RHG) equation:

$$C = 0.5961 + 0.0261\beta^2 - 0.216\beta^8 + 0.000521 \left( \frac{10^6 \beta}{Re_D} \right)^{0.7} + (0.0188 + 0.0063A)\beta^{3.5} \left( \frac{10^6}{Re_D} \right)^{0.3} + (0.0188 + 0.0063A)\beta^{3.5} \left( \frac{10^6}{Re_D} \right)^{0.3} + (0.043 + 0.8e^{-10L_1} - 0.123e^{-7L_1})(1 - 0.11A) \frac{\beta}{1 - \beta^4} - 0.031(M'_{2} - 0.8M'_{2}{}^{1.1})\beta^{1.3}$$

If the inside pipe diameter,  $D$ , is less than 2.8 in. (71 mm), the following term is added:

$$0.011(0.75 - \beta)(2.8 - D)$$

Where:

$$\beta = \frac{d}{D}$$

$Re_D$  is the pipe Reynolds number

For corner taps:  $L_1 = L'_2 = 0$

For D, D/2 taps:  $L_1 = 1, L'_2 = .47$

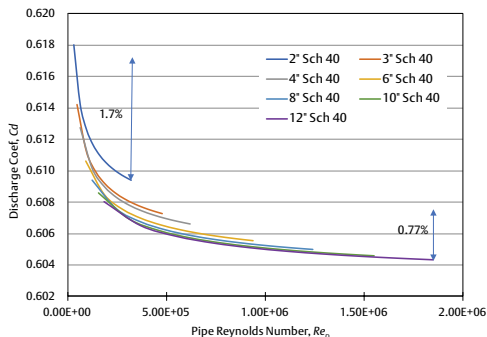
For flange taps:  $L_1 = L'_2 = \frac{1}{D}$

$$M'_{2} = \frac{2L'_2}{1 - \beta}, \text{ and } A = \left( \frac{19000\beta}{Re_D} \right)^{0.8}$$

The complexity of this equation allows a complete specification for the discharge coefficient for all tap types and  $\beta$ -ratios and has been programmed into flow computers that support orifice meters. The uncertainty of the calculated discharge coefficient is also given in the standards for an uncalibrated orifice plate.

Figure 7.10 shows the discharge coefficient,  $C$ , over Reynolds number for a  $\beta=0.60$  concentric orifice plate on water flow for 2-12 in. (50-300 mm) pipe sizes with flange taps. The changing value of  $C$  over the Reynolds number range is more pronounced for smaller pipe sizes.

**Figure 7.10:  $C$  vs.  $Re_p$  using the RHG equation for concentric flange tap orifice plates for a 0.60 beta water service. The percentages show the change in discharge coefficient for the 2-in. and 12-in. size.**

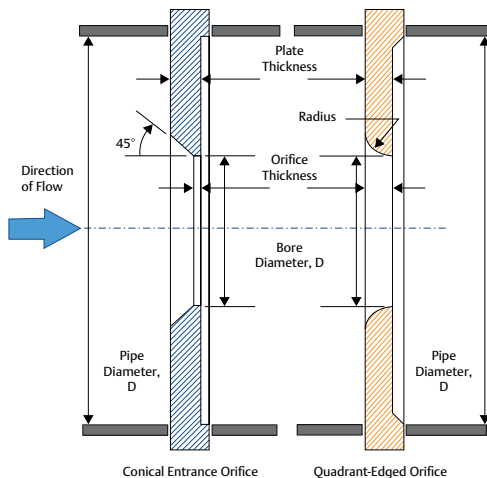


### 7.4.1.2 Special Orifice Plate Designs

To extend the application range of orifice plates, several alternative designs were developed. Four of the more common designs will be covered here:

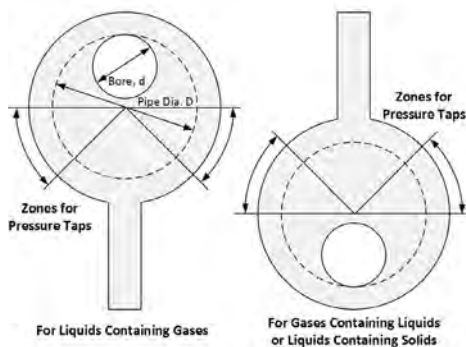
1. The conical orifice plate is essentially a square-edged orifice installed backwards, but it has a specific design that provides a linear discharge coefficient over a low Reynolds number range, so it is preferable for high-viscosity liquids. See Figure 7.11.
2. The quadrant-edged orifice plate is also used for high-viscosity liquids over a wider range of flow than the conical entrance plate, and the discharge coefficient is linear, but the differential pressure is lower. See Figure 7.11.

**Figure 7.11: Special-edged orifice plate designs.**



3. The eccentric orifice plate is used when there are liquids present in gases, or gases or solids present in liquids, to prevent buildup of these phases in front of the plate. Figure 7.12 shows the two mounting orientations and preferred tap locations for the eccentric orifice plate. The bore edge is made identically to the concentric orifice.

**Figure 7.12: The eccentric orifice plate.**

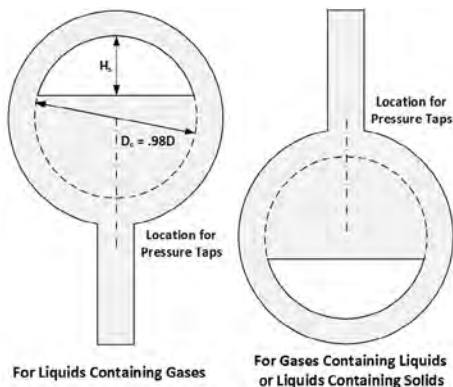


4. The segmental plate can also be used for the applications described for the eccentric plate. It is preferred for some liquid applications where solids may collect at the sides of a pipe using the eccentric plate and will also allow complete drainage of a horizontal pipe. Figure 7.13 shows the two methods for mounting

a segmental plate based on the fluid phase. The segment is defined by a semi-circle with a diameter slightly smaller than the pipe diameter,  $D_c$ , and the height of the segment,  $H_s$ . To calculate the equivalent beta for this type of plate, the following equation is used:

$$\beta_c = \frac{d}{D_c} = \left( \frac{1}{\pi} \left\{ \arccos \left( 1 - \frac{2H_s}{D_c} \right) - 2 \left( 1 - \frac{2H_s}{D_c} \right) \left[ \frac{H_s}{D_c} \left( \frac{H_s}{D_c} \right)^2 - \frac{1}{4} \right]^{\frac{1}{2}} \right\} \right)^{\frac{1}{2}}$$

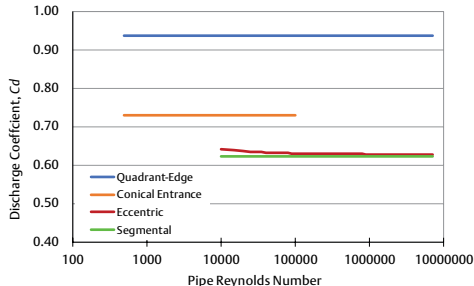
**Figure 7.13: The segmental orifice plate.**



If plate thickness requires, segmental plates will have a bevel on the downstream surface for the flat edge only.

Each special orifice plate design has a unique equation that is used to determine the discharge coefficient. [Figure 7.14](#) shows the discharge coefficient for each type with a 0.60 beta. As compared to the concentric sharp-edged orifice, the discharge coefficients are nearly constant for a large range of Reynolds number. However, due to the limited data, the uncertainty of the discharge coefficient for these designs is  $\pm 2\%$ .

**Figure 7.14:  $C$  vs.  $Re_d$  for special orifice plates for a 0.60 beta.**



### 7.4.1.3 Conditioning Orifice Plate

The use of orifice plates is widespread, and they have become one of the most commonly used DP flow meters. However, they have one drawback: the required straight run of pipe needed to obtain the rated performance is not always available. In many refining and chemical facilities, real estate is at a premium and so space is limited. Some areas of the plant are built on platforms or skids, and there are no sufficiently long lengths of straight pipe for a traditional orifice plate flow meter. For this reason, the Conditioning Orifice Plate was developed.

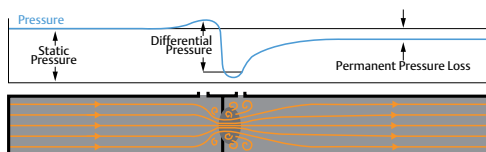
There are other manufacturers that produce what are generically called multi-hole orifice plates. The purpose is the same: to reduce the amount of straight pipe required and still provide good performance from an orifice plate. [Figure 7.15](#) shows some of the available multi-hole orifice designs. The 4-bore Conditioning Orifice Plate is shown in the lower right of the figure.

**Figure 7.15: A few examples of multi-hole orifice plates.**



The Conditioning Orifice Plate is a combination of a flow conditioner (i.e., flow straightener) and an orifice plate. From a fluid dynamics standpoint, the purpose of the hole pattern in the plate is to provide a consistent downstream flow field that is unaffected by the upstream fluid dynamics. When the flow through the plate is broken up into smaller flow streams, the resulting flow distribution is forced into a pattern that gives the least energy loss. *Figure 7.16* shows the pressure profile for a traditional orifice plate.

**Figure 7.16: Orifice plate pressure profile.**



Most of the differential pressure generated by an orifice is due to the downstream pressure. When fluid flow streams through the holes of a multi-hole plate in an undeveloped flow, they are forced into the same pattern as that for a developed flow, and the resulting flow field downstream provides the same pressure field. This gives a discharge coefficient that is nearly unaffected by the turbulence upstream. Nature takes the path of least resistance, which results in a consistent downstream pressure field for the multi-hole orifice plate.

*Table 7.8* shows the straight pipe requirements for a Conditioning Orifice Plate and a traditional orifice plate for several common upstream pipe fittings. The Conditioning Orifice Plate with a 0.50 beta for most disturbances requires a total of only four pipe diameters, as compared to an equivalent traditional orifice plate after a single elbow (without a flow straightener) at 28 pipe diameters. This development has revolutionized the use of orifice plates in flow meter applications where it was not possible before.

**Table 7.8: Conditioning and traditional orifice plate straight run pipe requirements.**

**Rosemount Conditioning Orifice Plate**

Upstream to Meter for Orifice Beta	0.20	0.40	0.50	0.65
Single 90° bend or tee	2	2	2	2
Two or more 90° bends in the same plane	2	2	2	2
Two or more 90° bends in different plane	2	2	2	2
Reducer (1 line size reduction)	2	2	2	2
Any fitting or combination generating up to 10° of swirl	2	2	2	2
Ball valve — 75 to 100% open	2	2	5	5
Downstream from meter	2	2	2	2

**Traditional Orifice Plate**

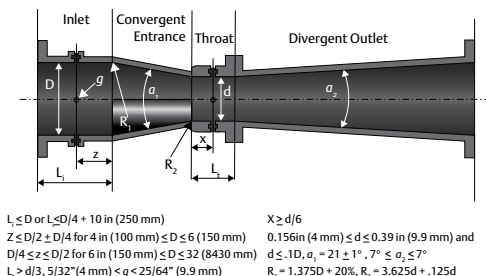
Upstream to Meter for Orifice Beta	0.20	0.40	0.50	0.65
Single 90° bend or tee	6	16	22	44
Two or more 90° bends in the same plane	10	10	22	44
Two or more 90° bends in different plane	19	44	44	44
Reducer (2 to 1D over 1.5 to 3D in length)	5	5	8	12
Expander (0.5D to D over D to 2D in length)	6	12	20	28
Ball/gate valve, fully open	12	12	12	18
Downstream from meter	4	6	6	7

## 7.4.2 Venturi Tube

The Venturi tube is named after Giovanni Battista Venturi, who was an Italian physicist in the 18<sup>th</sup> century. He discovered what would later be called the Venturi principle. This confirmed what Bernoulli's simple equation showed: the difference in pressure of a fluid as it flows through a restriction is related to the area difference, or the difference in the square of the velocity at each section.

Although the paper by Giovanni Venturi on this concept was published in 1797, a practical Venturi tube was not developed until 1888 by Clemens Herschel, an Austrian-born American hydraulics engineer who lived in New York and worked on many hydraulic projects in the area. Herschel developed and patented the Venturi tube to measure water for the mills in Holyoke, Massachusetts. This makes the Venturi tube the oldest patented DP flow meter. Now called the classic or Herschel Venturi tube, the first version of this flow meter used included angles of 21° for the entrance cone and 7° for the exit cone with a throat length equal to the throat diameter. *Figure 7.17* shows the dimensions of the Herschel Venturi tube. The taps use piezometers (i.e., pressure-equalizing rings) to average the inlet and throat pressures. The long exit cone allows most of the reduction in pressure to be recovered, so Venturi tubes have a very small PPL. The Venturi tube has no sharp edges to wear down, and the gradual profiles make it ideal for solid-laden liquids such as unfiltered water or sewage. It is still in wide use today, and there are many manufacturers.

**Figure 7.17: The classic or Herschel Venturi tube.**



Smaller Venturi tubes can be machined from a single piece of brass, steel, or stainless steel, or made from injection-molded plastic. Larger Venturis can be cast out of bronze, iron, or steel in separate sections and flanged together or fabricated using sheet stock and flanged or welded together. *Figure 7.18* shows Venturi tubes used for industrial flow metering. This type of Venturi tube is relatively long, and for a 0.50-, 0.60-, and 0.70-beta unit, will be 7, 6, and 5 pipe diameters long, respectively.

**Figure 7.18: Industrial-flanged Venturi tubes.**



Standards for the Venturi tube are:

1. ISO 5167-4:2003 Measurement of fluid flow by means of pressure differential devices inserted in circular cross section conduits running full – Part 4: Venturi tubes
2. ASME MFC-3: Measurement of Fluid Flow in Pipes Using Orifice, Nozzle, and Venturi

### 7.4.2.2 Short-Form Venturi Tube

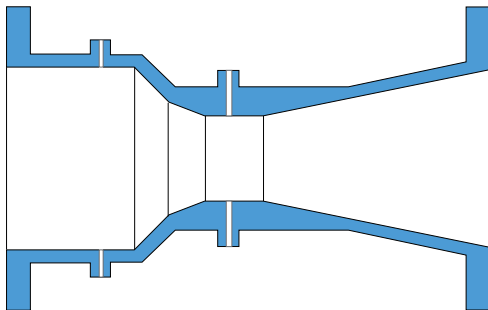
The long lengths of the Herschel Venturi tube prompted the short-form Venturi, which is made shorter by truncating the exit cone to about 70% of the original length. This increases the PPL somewhat, but it is small compared to other area DP meters.

### 7.4.2.3 Universal Venturi Tube

The Universal Venturi Tube is similar to the short-form Venturi, but there are two entrance cone sections to keep the flow attached to the wall and the section short. The throat section and diffusing or exit cone are also shortened. This eliminates the long length and retains the low PPL. The

Universal Venturi Tube was introduced in the early 1970s and is one of the preferred forms of the Venturi tube for larger pipe sizes. [Figure 7.19](#) shows a section view of a Universal Venturi Tube.

**Figure 7.19: The Universal Venturi tube.**



### 7.4.3 Flow Nozzle

A nozzle is used to create a high-velocity jet for propulsion or to direct a fluid stream. A flow nozzle is a type of area DP flow meter that is designated as a contoured meter. See [Figure 7.20](#).

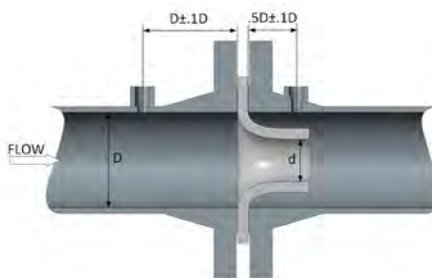
**Figure 7.20: A flow nozzle.**



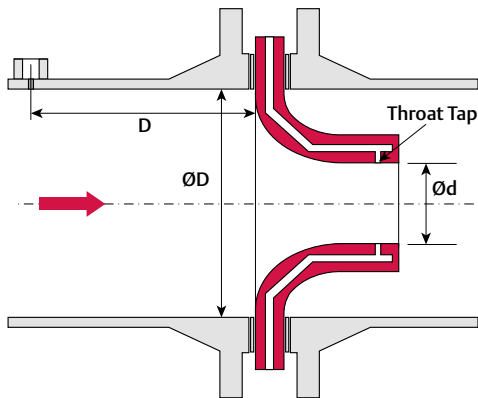
The first patent on the flow nozzle was assigned to Austin R. Dodge in 1919, who was working on steam turbine efficiency at the General Electric Company. He was looking to make a flow meter like the orifice plate but without the sharp edge. The nozzle functions similarly to a Venturi tube, but it typically doesn't have a divergent or exit cone. The contour directs the flow to the throat in a relatively short length, and the absence of a divergent cone allows the installation of the nozzle between flanges. The robust construction of the flow nozzle has made this type of primary the first choice for high temperature, high velocity

applications like the main steam line to a turbine. [Figure 7.21](#) shows the installation of a nozzle in a pipe using radius taps. A variation on this design is the throat-tap version, as specified in ASME Power Test Code (PTC) 6, as shown in [Figure 7.22](#). In this design, the low pressure is measured in the nozzle throat. This version is used in the power industry to measure steam flow.

**Figure 7.21: A flow nozzle in a pipe with radius taps.**



**Figure 7.22: ASME nozzle with throat taps.**

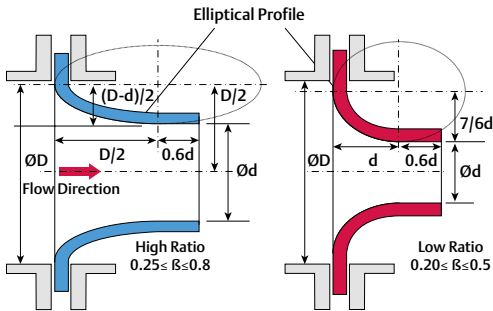


#### 7.4.3.1 Non-Proprietary Nozzle Designs

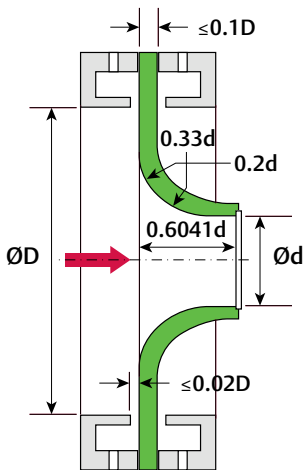
There are two non-proprietary designs of nozzles that are popular today: the ASME long-radius and the International Standards Association (ISA) 1932 nozzle. The ASME nozzle uses an elliptical inlet, and the ISA nozzle uses a radial inlet. [Figure 7.23](#) shows the two types of ASME long-radius nozzles. The nozzle contour is a quarter of an ellipse. The

two styles are needed to provide the usual range of beta in the space available. All the critical nozzle dimensions are multiples of the pipe or throat diameter.

**Figure 7.23: ASME long-radius nozzle types.**



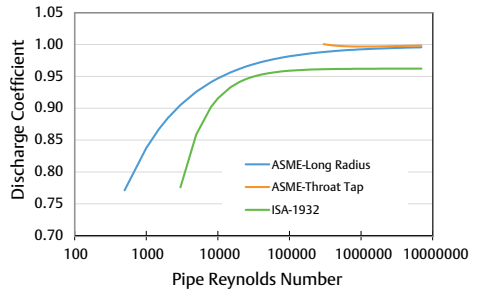
**Figure 7.24: ISA 1932 nozzle design.**



The ISA nozzle design is shown in [Figure 7.24](#). It uses corner taps with or without piezometer rings. The two radii are tangent to the bore and upstream surface. It is primarily used outside the U.S. As with the orifice plate, these DP meter primary devices are design types and the specification for their fabrication allowed

calibration data to be generated. The more data collected, the more confidence there is in the calculated discharge coefficient. [Figure 7.25](#) shows the discharge coefficient for these three non-proprietary flow nozzle designs.

**Figure 7.25: Discharge coefficient for the non-proprietary flow nozzles.**



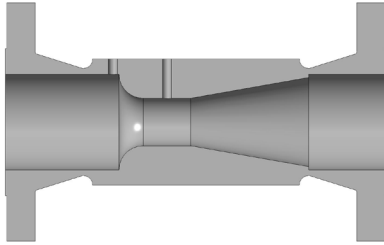
Standards for the flow nozzle are:

1. ISO 5167-3:2003 Measurement of fluid flow by means of pressure differential devices inserted in a circular-cross section conduits running full — Part 3: Nozzles and Venturi nozzles
2. ASME MFC-3M: Measurement of Fluid Flow in Pipes Using Orifice, Nozzle, and Venturi

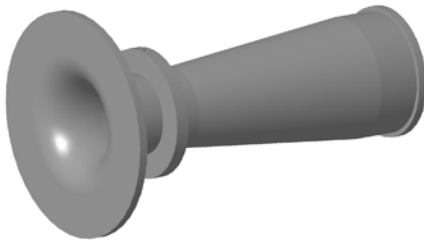
### 7.4.3.2 Venturi Nozzle

It was a matter of time before the two types of meters — Venturis and nozzles — would be combined to make a composite meter, resulting in the Venturi nozzle where an exit cone is attached to a flow nozzle. To retain the robustness of the nozzle, the Venturi nozzle is available in a version that can be inserted into the pipe and mounted between flanges. As a result, the PPL for this nozzle is greatly reduced. [Figure 7.26](#) shows a flanged version, and [Figure 7.27](#) shows the Venturi nozzle tube insertable configuration.

**Figure 7.26:** A flanged Venturi nozzle.

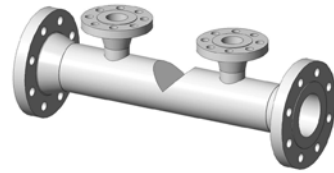
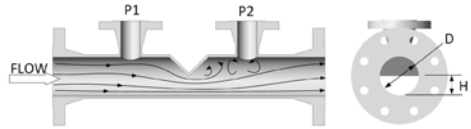


**Figure 7.27:** The insertable Venturi nozzle.



liquids can be measured by a special version of the wedge primary element.

**Figure 7.28:** Wedge primary element.



### 7.4.4 Wedge Primary Element

The open area of a wedge primary element is a circular segment, much like the segmental orifice plate. However, the wedge primary element has a sloping surface on both sides of the restriction, which is where the wedge primary element gets its name. This feature directs the flow under the restriction, which minimizes the collection of entrained solids. *Figure 7.28* shows the wedge primary element and the equation used to determine the equivalent circular bore beta ratio,  $\beta_{eq}$ , based on the height of the open segment,  $H$ , and the pipe diameter,  $D$ . The relationship between  $H/D$  and the equivalent beta is:

$$\beta_{eq} = \frac{d_{eq}}{D} = \left( \frac{1}{\pi} \left\{ \arcsin \left( 1 - \frac{2H}{D} \right) - 2 \left( 1 - \frac{2H}{D} \right) \left[ \frac{H}{D} \left( \frac{H}{D} \right)^2 \right]^{\frac{1}{2}} \right\} \right)^{\frac{1}{2}}$$

Despite this unimposing, simple concept, the wedge primary element handles flow meter applications that no other DP flow meter can. Slurries, high viscosity, and solid-contaminated

The wedge primary element was developed in the 1960s in the mining industry to measure difficult flow applications. It was first patented and sold by Taylor Meter in the mid-1970s. After the patent expired, other manufacturers duplicated and sold alternate versions of this concept. Tap location, tap diameter, wedge angle, and edge radius could all affect the discharge coefficient. Currently, each manufacturer has a set of equations for predicting the value of the discharge coefficient that are unique to their design.

Due to the methods of fabricating wedge primary elements and the fact that the pipe defines the segmental area, using a calculated discharge coefficient will give a value that is only within  $\pm 5$  to 8% of the true value. For this reason, the wedge primary element is typically calibrated. The wedge primary element is quite linear to the Reynolds number, and a calibrated meter can claim an uncertainty of  $\pm 0.5\%$ . Some wedge primary element designs use wedge components and pipe bores that are machined. This type of wedge primary element should provide a discharge coefficient with better confidence, but manufacturers typically don't share this information.

For the most difficult applications mentioned earlier, it is necessary to provide the wedge



primary element with large impulse pipe connections and use diaphragm seals with the DP transmitter. Diaphragm seals must be connected to the DP transmitter during fabrication and use oil-based fill-fluids to convey the DP signal without transmitter contact with the process fluid. To increase the sensitivity of this type of system, large diaphragms for 2- or 3-in. pipe sizes (50 or 80 mm) are used. The additional oil fill and diaphragm flex of the seals reduces the response time of the flow meter and requires a minimum DP to work, so it can not be used for some applications. [Figure 7.29](#) shows Emerson’s Rosemount™ DP transmitter with integral 3-in. (80 mm) flanged diaphragm seals installed using armored cable to protect the small seal tubing.

**Figure 7.29: Rosemount DP transmitter with integral 3-in. (80 mm) ANSI-flanged diaphragm seals.**

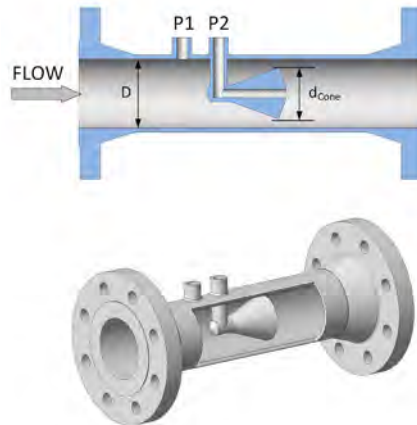


A standard for the wedge primary element is: ISO 5167-3:2003 Measurement of fluid by means of pressure differential devices inserted into a circular cross-section conduits running full — Part 4: Wedge meters.

### 7.4.5 Cone Meter

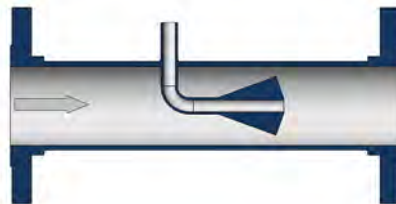
The cone meter is an area meter that uses a cone-shaped body in a pipe spool to create a restriction. See [Figure 7.30](#). The high-pressure tap reads the pipe static pressure upstream of the cone, and the low pressure is read at the rear of the cone, or for some versions, holes drilled around the cone perimeter.

**Figure 7.30: The cone meter.**



The original form of the cone meter came from a design for a steam desuperheater, shown in [Figure 7.31](#), where water was injected in a steam pipe to lower the energy of the steam and maintain saturated conditions after a pressure regulator. Once it was discovered that the device could be used as a DP flow meter, a new area DP meter was born.

**Figure 7.31: Steam desuperheater.**



As with the wedge primary element, the equivalent beta for the cone meter is calculated and used in the standard DP equation:

$$\beta_{eq} = \sqrt{1 - \frac{d_{cone}^2}{D_{pipe}^2}}, \text{ where:}$$

$d_{cone}$  Diameter of the cone base

$D_{pipe}$  Inside diameter of the pipe

The cone meter also uses the pipe to define the meter bore so the uncertainty of the discharge coefficient for a specific meter is  $\pm 5$  to  $8\%$  unless the meter is calibrated. A calibrated cone meter discharge coefficient is quite linear and can achieve an uncertainty of  $\pm 0.5\%$ .

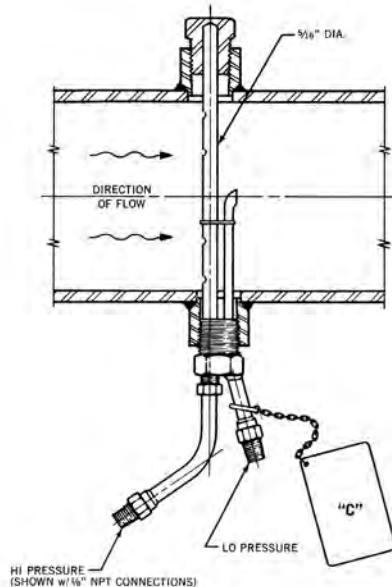
The patent for the original cone meter is now expired. A standard called ISO 5167-5:2016 — Part 5: Cone Meters is in place. This standard defines the cone meter design type. Cone meters are used in every type of fluid flow application and have been characterized for wet gas flows.

### 7.4.6 Averaging Pitot Tube

In 1967, Dietrich Standard Inc., which was later acquired by Emerson, introduced the Annubar primary element for the Heating Ventilation and Air Conditioning (HVAC) market. [Figure 7.32](#) shows the original drawing for the Annubar flow element. The name was derived from the term ANNular Averaging BAR. Interest from the industrial market ensued, and soon the Annubar Averaging Pitot Tube was selling worldwide for applications in most industries. Few technical documents were available that explained the operation of the device. The averaging pitot tube product documentation usually showed the area meter Bernoulli equation and mentioned the  $S$  value, used in the meter sizing equations, as the flow coefficient having a constant value for any application range.

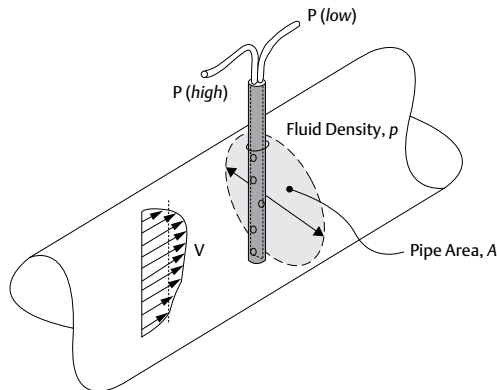
Other manufacturers of averaging pitot tube devices sprung up, and soon there was a plethora of devices all claiming the same performance and leveraging the acceptance of the original Annubar Averaging Pitot Tube. Without any standard or appropriate technical guidance, the claims and trust that the chosen averaging pitot tube would work in a given application had to be accepted.

**Figure 7.32: An original drawing of the first averaging pitot tube, called the Annubar.**



[Figure 7.33](#) shows a generic version of the contemporary averaging pitot tube. There are several variations of this design, primarily in the cylinder shape, the method of positioning the sampling holes or ports, and the arrangement of pressure tubes that pick up the high- and low-pressure readings inside the cylinder. However, all averaging pitot tube designs function in the same basic manner.

**Figure 7.33: A generic averaging pitot tube in a pipe.**



The averaging pitot tube is a sampling, or insertion, meter. This means that it is seeing only a portion of the flow field. For a developed flow, this is not an issue, as a sample of any diameter represents the whole. For undeveloped flow, it matters where the averaging pitot tube is inserted into the pipe. This is known as the orientation.

Figure 7.34 shows the conventional averaging pitot tube geometry as mounted in a circular pipe with a velocity gradient or profile upstream. The first question is whether the average velocity across the measured diameter,  $V_D$ , is equal to the bulk average velocity, or,  $V_B$ , where:

$$V_B = \frac{Q_v}{A}$$

A factor that relates these two velocities is:

$$F_{PD} = \frac{V_B}{V_D}$$

For a developed flow,  $F_{PD} = 1$ , and for any other type of flow,  $F_{PD} \neq 1$ , and may affect the calculated flow rate. The incompressible volumetric flow equation for the averaging pitot tube is:

$$Q_v = KA \sqrt{\frac{2g_c(P_H - P_L)}{\rho}}$$

and for mass flow:

$$Q_m = KA \sqrt{2g_c(P_H - P_L)} \rho$$

Where:

$Q_v$  Volumetric flow rate,  $ft^3/sec$  ( $m^3/sec$ )

$Q_m$  Mass flow rate,  $lb_m/sec$  ( $kg/sec$ )

$K$  Flow coefficient, dimensionless

$A$  Pipe area at the averaging pitot tube,  $ft^2$  ( $m^2$ )

$P_H - P_L$  Differential pressure,  $lb_f/ft^2$  ( $N/m^2$ )

$g_c$  Initial force conversion constant,  $32.174 lb_m \cdot ft / lb_f \cdot sec^2$  ( $1 kg \cdot m / N \cdot sec^2$ )

$\rho$  Fluid density,  $lb_m/ft^3$  ( $kg/m^3$ )

These equations are identical to that of any other DP flow meter. The flow coefficient is given by:

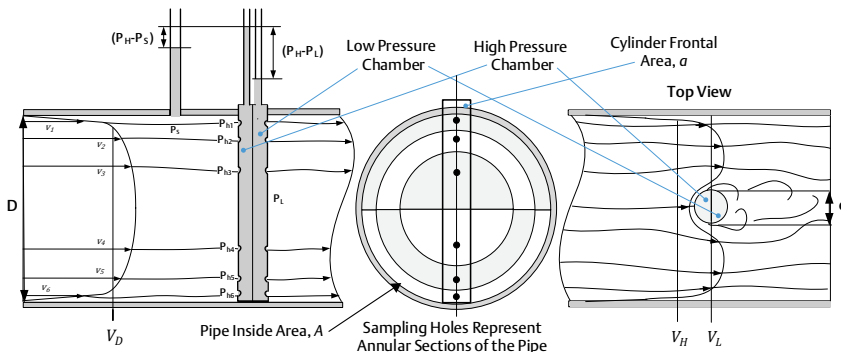
$$K = \frac{\text{True or Real Flow Rate, } Q_R}{\text{Theoretical Flow Rate, } Q_T}$$

Where the true flow rate is determined in the flow laboratory, and the theoretical flow rate is the value calculated in the equations with  $K=1$ . See Chapter 3 for more information on the averaging pitot tube flow equation.

### 7.4.6.1 Sampling the Velocity Profile

The next function to address is the velocity sampling being done by the upstream averaging pitot tube chamber or plenum. Figure 7.34 shows the basic geometry of an averaging pitot tube in a pipe. The averaging of the velocity for the averaging pitot tube shown is sampled with six

Figure 7.34: Geometry for an averaging pitot tube.



holes located on the front of the cylinder. Each hole represents an annular section of the circular pipe. The pressure generated by the impact of the fluid at the outside of each hole is caused by the velocity at that location and contributes to the high-pressure reading of the averaging pitot tube. Most averaging pitot tube designs use discrete holes that are positioned using one of two sampling methods:

1. The Centroid of Equal Areas
2. The Chebyshev Method

These methods use equal weighting (i.e., where the sampled average is merely the sum over the number of samples). Equal weighting is necessary for an averaging pitot tube as there is no way to weight one sample over another. For the turbulent flow region (i.e., flows above a pipe Reynolds number of 4000), both methods give a good approximation to the average velocity.

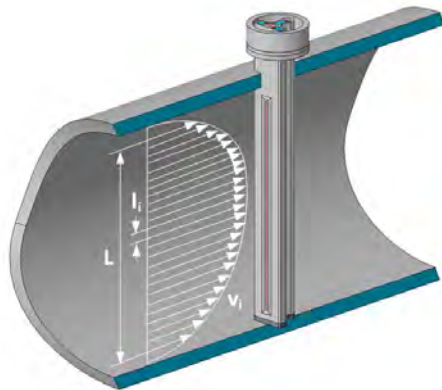
**Table 7.9** shows the location of sample points by percentage pipe radius. An averaging pitot tube would place twice the sampling holes using these locations on either side of the pipe centerline.

**Table 7.9: Sample point locations,  $r_i/R$ , centroid of equal areas.**

Pt No.	2-Pts/Rad	3-Pts/Rad	4-Pts/Rad	5-Pts/Rad	6-Pts/Rad
1	0.5000	0.4082	0.3536	0.3162	0.2887
2	0.8660	0.7071	0.6124	0.5477	0.5000
3		0.9129	0.7906	0.7071	0.6544
4			0.9354	0.8367	0.7638
5				0.9487	0.8660
6					0.9574

**Figure 7.35** shows the Rosemount 485 Annubar™ Primary Element, which uses slots instead of holes to read the average velocity. Slots also do a good job at sampling the upstream velocity, but analyzing the pressure averaging requires a different method than for discrete holes. The slot does not use a sampling method like the sample holes, as the slot is continuous.

**Figure 7.35: The Rosemount 485 Annubar Primary Element with a slot to measure the high pressure.**



The equation that relates the slot length to the average velocity is:

$$\bar{v} = \sum_{i=1}^N v_i l_i / LN$$

Where:

- $\bar{v}$       Averaged upstream velocity
- $v_i$       Velocity at the  $i$ th location
- $l_i$       Incremental distance between points
- $L$         Length of the slot
- $N$         Number of increments measured

Refer to **Chapter 9** for more information on the Annubar primary element.

### 7.4.6.2 Averaging Pitot Tube Low or Reference Pressure

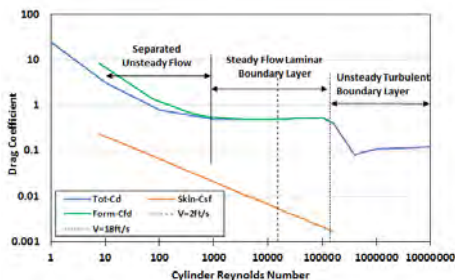
All differential pressure flow primary devices need a low-pressure component. An averaging pitot tube could use the pipe static pressure as the low side, as shown in **Figure 7.34**. However, most averaging pitot tube designs do not use the static pressure. Instead, they use low, or reference, pressure measured on the averaging pitot tube cylinder. This is because:

1. Only one pipe penetration for measurement is required, which allows for a simpler installation and hot tapping the averaging pitot tube.
2. The DP is much higher if the low pressure is read at the rear of the cylinder.

The first Annubar Averaging Pitot Tube used a rear-facing port to read the reference pressure. Later versions were built into a single circular tube with the pressure sensed at the rear, or base, of the cylinder. It turned out that the circular cylinder, while easy to fabricate, was not a good choice. A circular cylinder in cross flow goes through several regimes where the fluid dynamics at the cylinder surface are changing. These changes cause a change in the local pressure on the surface relative to the fluid stagnation pressure. This causes a change in the flow coefficient over the operating range, which is not desirable for a flow meter.

Figure 7.36 shows a graph of the circular cylinder drag coefficient for these regimes. The range for typical industrial flow meter applications starts at the dashed line, and for gas and steam flows, goes to the limit of the graph, making the transition to a turbulent boundary layer right in the middle. The drag coefficient matters due to the need to estimate the drag on an aircraft. There is significant data on drag for various cylinder shapes.

**Figure 7.36: Circular cylinder drag coefficient vs. Reynolds number for a 1-in. (25 mm) diameter cylinder.**



The drag coefficient is very close to the inverse square of the averaging pitot tube flow coefficient, or:

$$C_D \cong \frac{1}{K^2}$$

This means that drag coefficient data for a cylinder in cross flow can give a prediction of the behavior of an averaging pitot tube flow coefficient when made from a similar shape, if the low pressure is measured at the cylinder base. Due to the similarity with the drag coefficient, this type of low-pressure sensing hole arrangement is called a drag port.

Figures 7.37 and 7.38 show the drag coefficient for two shapes of cylinders: a square with the vertex facing the flow (i.e., diamond shape) and a 2 x 1 rectangle with the largest side facing the flow.

Notice that as the edges are rounded in both cases, the data shows the same change in drag coefficient as seen for the circular cylinder. This shows that the edges of the cylinder create a constant relationship between the dynamic pressure and the pressure at the rear of the cylinder for a wide Reynolds number range. This is necessary if an averaging pitot tube is to provide the linearity needed for an industrial flow meter.

The diamond shape was used for all Annubar Averaging Pitot Tube models from 1978 to 2000 and is still used today for the Rosemount 585 Severe Service Annubar Primary Element. The rectangular shape represents what is currently used for the Rosemount 485 Annubar.

Figure 7.37: Drag coefficient of a diamond cylinder.<sup>1</sup>

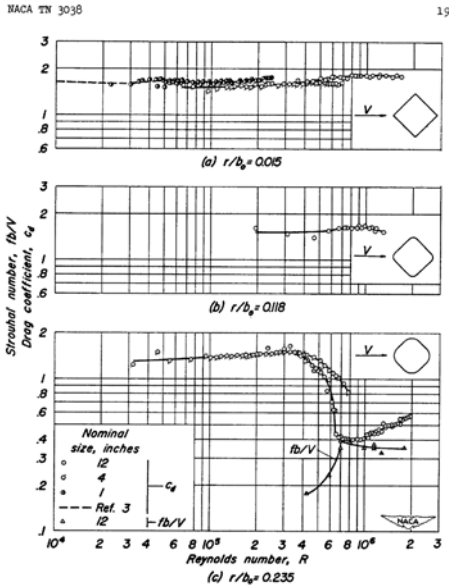
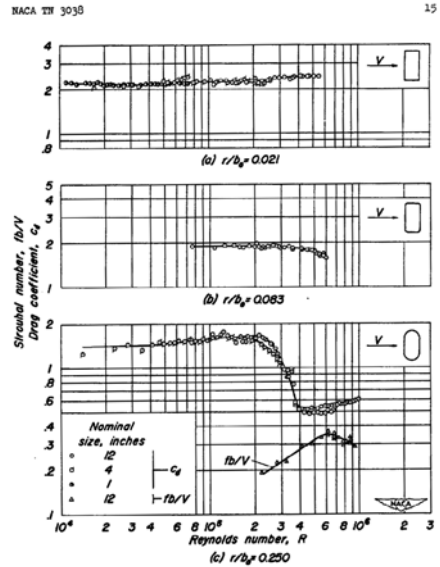


Figure 7.38: Drag coefficient for a rectangular cylinder.<sup>1</sup>



### 7.4.6.3 Averaging Pitot Tube Pressure Coefficients and the Flow Coefficient

From a fluid dynamics view, the drag port averaging pitot tube can be separated into a front and rear section. The high pressure generated by the front section is due to fluid stagnation and behaves according to the Bernoulli principle. The low pressure is generated after fluid separation and is due to viscous losses as well as the change in area due to the presence of the cylinder in an enclosed pipe.

<sup>1</sup>Noel K. Delany and Norman E. Sorenson, "Low-Speed Drag of Cylinders of Various Shapes," NACA Technical Note No: 3038, November, 1953.

From [Chapter 3](#), the practical averaging pitot tube volumetric flow equation is:

$$Q_v = NKD^2 \sqrt{\frac{(P_H - P_L)}{\rho}}$$

For a drag port averaging pitot tube, the flow coefficient is:

$$K = \frac{F_{PD}}{\sqrt{C_{pH} + |C_{pL}|}}$$

Where:

$C_{pH}$  High-pressure coefficient

$C_{pL}$  Low-pressure coefficient

The value and linearity of  $C_{pH}$  is affected by the sampling method used and represents the average stagnation pressure in the pipe. It would normally have a value of 1, but it is slightly larger than 1 due to the presence of the averaging pitot tube cylinder. The equation for  $C_{pH}$  is:

$$C_{pH} = \frac{(P_H - P_S)}{(\alpha \rho \bar{V}_D^2 / 2g_c)}$$

Where, in U.S. Customary (USC) units (SI units):

$P_H$  High-pressure read at the averaging pitot tube tap,  $lb_f/ft^2$  ( $N/m^2$ )

$P_S$  Pipe static pressure,  $lb_f/ft^2$  ( $N/m^2$ )

$\alpha$  Kinetic energy coefficient, dimensionless (see [Chapter 3](#))

$\rho$  Fluid density,  $lb_m/ft^3$  ( $kg/m^3$ )

$\bar{V}_D$  Average fluid velocity at the pipe diameter spanned by the averaging pitot tube cylinder,  $ft/s$  ( $m/s$ )

$g_c$  Inertial-force conversion constant,  $32.174 \frac{lb_m \cdot ft}{lb_f \cdot sec^2}$  ( $1 \frac{kg \cdot m}{N \cdot sec^2}$ )

The value and linearity of  $C_{pL}$  is affected by the cylinder shape and the ratio of cylinder to pipe size (i.e., blockage). The equation for  $C_{pL}$  is:

$$C_{pL} = \frac{(P_L - P_S)}{(\alpha \rho \bar{V}_L^2 / 2g_c)}$$

Where:

$P_L$  Low-pressure read at the averaging pitot tube tap,  $lb_f/ft^2$  ( $N/m^2$ )

$\bar{V}_L$  Average fluid velocity at the widest portion of the averaging pitot tube cylinder, which is slightly larger than the upstream velocity due to cylinder blockage (see [Figure 8.38](#)),  $ft/s$  ( $m/s$ )

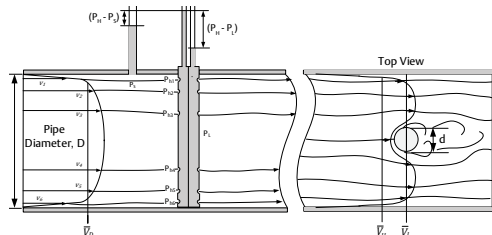
Because of vortex shedding, the averaging of the low pressure at the rear of the cylinder has a small influence on the low-pressure measurement.

While the pressure coefficients give an insight to the averaging pitot tube operation, empirical data is required to determine the true flow coefficient value based on the true pipe flow rate and fluid conditions. This is typically done for developed flows where  $F_{PD} = 1$ .

#### 7.4.6.4 Blockage vs. the Averaging Pitot Tube Flow Coefficient

As with the other DP meters, the averaging pitot tube needs a flow coefficient that can be predicted for any appropriate application. For a successful averaging pitot tube design, the flow coefficient will be relatively linear over the range of flow rate or Reynolds number for a given application. The value of the flow coefficient will depend on the cylinder shape, sensing hole system, and the area change. For an area DP meter, the area change is determined by the value of beta. For an averaging pitot tube, it is determined by what is called the sensor blockage. [Figure 7.39](#) shows the generic averaging pitot tube from the top and the fluid profile as it flows around the averaging pitot tube cylinder.

**Figure 7.39: Averaging pitot tube blockage.**



Starting with the continuity equation for incompressible flow:

$$\bar{V}_D A = \bar{V}_L (A - a), \text{ where:}$$

$\bar{V}_L$  Average fluid velocity at the widest section of the averaging pitot tube cylinder, which is generating the low pressure

$A$  Area of the pipe at the averaging pitot tube

$a$  Projected area of the sensor cylinder,  $d \times D$ , where  $d$  is the width of the cylinder

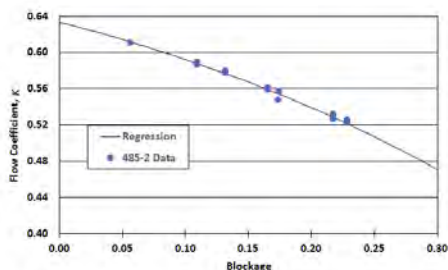
Solving for  $\bar{V}_D$ :

$$\bar{V}_D = \bar{V}_L (1 - a/A) = \bar{V}_L (1 - 4d/\pi D) \text{ for round pipes}$$

Define the blockage ratio:  $B = a / A = 4d / \pi D$ , and add a multiplier to apportion the effects of blockage:

$\bar{V}_D = \bar{V}_L (1 - C_b B)$ , where  $C_b$  is determined empirically. This parameter will affect the value of the low-pressure coefficient,  $C_{pL}$ .

**Figure 7.40: Flow coefficient vs. blockage data.**



The averaging pitot tube now has an equivalent beta, which can be used to predict the flow coefficient when plotted against the value of  $B$  for each cylinder size. If the viscous losses and the pressure sampling are consistent for a given averaging pitot tube cylinder size, the plot of flow coefficient data should show a continuous function from the highest blockage to the lowest.

Figure 7.40 shows this plot for a Rosemount 485 Annubar Primary Element with a regression curve-fit done using calibration data.

The equation for this curve-fit has the form:

$$K = \frac{(1 - C_2 B)}{\sqrt{1 + C_1 (1 - C_2 B)^2}}$$

Where:

$C_1$  A constant proportional to the cylinder low-pressure coefficient

$C_2$  A constant due to the effects of blockage and is equivalent to the value for  $C_b$  shown earlier

The benefit of this plot is that the value of the flow coefficient can now be calculated for any pipe size by knowing only the pipe inside diameter and the width of the sensor.

### 7.4.6.5 Sizing the Averaging Pitot Tube

When an averaging pitot tube cylinder is installed in a pipe, it is exposed to fluid loading in the form of the drag force in the direction of flow and an oscillating side load due to vortex shedding. These loads need to be predicted and checked against the chosen averaging pitot tube model during product configuration to ensure that the selected averaging pitot tube will not structurally fail due to fluid loading.

There are two engineering disciplines that must come together to size an averaging pitot tube:

1. Fluid dynamics for flow around a cylinder
2. Beam mechanics to determine the effects of the load on the cylinder

When the forces due to fluid flow on the averaging pitot tube are equated to the maximum load available (with a safety factor) for the cylinder, a limit of flow rate or differential pressure is established for the averaging pitot tube. If it is determined that the maximum load is exceeded for a given averaging pitot tube model, there are some options:

1. A larger averaging pitot tube cylinder can be selected.
2. The cylinder can be supported at both ends.



The fluid loading is calculated by using the formula presented earlier for the cylinder drag:

$$W_D = C_D \frac{\rho V^2}{2g_c} A_D, W_L = C_L \frac{\rho V^2}{2g_c} A_L, \text{ where:}$$

$W_D$  Drag load in the direction of flow,  $lb_f (N)$

$C_D$  Drag coefficient, dimensionless

$A_D$  Projected area of the cylinder in the flow direction,  $ft^2 (m^2)$

$W_L$  Lift load perpendicular to the direction of flow,  $lb_f (N)$

$C_L$  Lift coefficient, dimensionless

$A_L$  Projected area of the cylinder perpendicular to the flow direction,  $ft^2 (m^2)$

$V$  Average fluid velocity for the averaging pitot tube,  $ft/sec (m/sec)$

The values of the fluid-load coefficients,  $C_D$  and  $C_L$ , must be determined empirically by observing the deflection of the sensor cylinders under fluid load.

Due to the oscillating nature of the vortex shedding from a bluff body, the alternating side or lifting load can become larger and more damaging than the drag load.

Figure 7.41 shows the vortex generation from a cylinder and the string of eddies, or street, left in the wake.

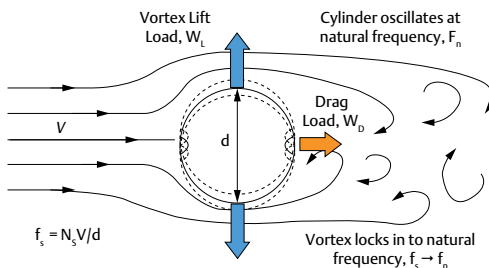
**Figure 7.41: A vortex street for a cylinder in cross flow.**



The study of vortex shedding frequency for rigid structures shows that when the structure begins to move, it will vibrate at the resonant or natural frequency,  $f_n$ . Once a cylinder vibrates with an amplitude of about  $0.1 \times d$  or greater, however, the vortex becomes organized (i.e., sheds in unison over the cylinder length), the drag load increases, and the vortex shedding frequency ( $f_s$ ) will synchronize with the movement, or  $f_s \rightarrow f_n$ . This synchronization of vortex shedding frequency

( $f_s$ ) to cylinder natural frequency, called lock in, can cause an averaging pitot tube to fail very quickly. Figure 7.42 shows this graphically.

**Figure 7.42: Averaging pitot tube cylinder fluid loading and lock-in.**



The vortex shedding frequency,  $f_s$ , is related to the fluid velocity and cylinder width by:

$$f_s = \frac{N_s \times V}{d}, \text{ where:}$$

$N_s$  Strouhal number for the cylinder, dimensionless

The Strouhal number relates the fluid velocity and cylinder size to the frequency of the vortex. It must be determined for the specific averaging pitot tube cylinder, unless it is a common shape, such as a circle, diamond, etc. Cylinders with sharp edges tend to have a constant value of  $N_s$  over a wide range of flow (see data for  $fb/V$  in Figures 7.37 and 7.38), whereas a circular or non-sharp-edged cylinder show a changing value.

There are two calculations that should be done to ensure that the averaging pitot tube will not fail:

1. The maximum allowed loading of the averaging pitot tube in both directions (for the drag and the lift loads) must be checked for the given model, material, and mounting type.
2. The vortex shedding frequency range for the application and the averaging pitot tube cylinder resonant frequency for the given model, material, and mounting type must be calculated to ensure that they will not synchronize and that lock in will not occur.

### 7.5 Applicable Flow Meter Standards

There are some published standards for flow meters:

1. ISO 5167: Measurement of fluid flow by means of pressure differential devices inserted in a circular-cross section conduits running full – Part 2: Orifice plates, Part 3: Nozzles and Venturi nozzles, Part 4: Venturi tubes, and Part 6: Wedge meters
2. ASME MFC-3M: Measurement of Fluid Flow in Pipes Using Orifice, Nozzle, and Venturi
3. ASME MFC-14M: Measurement of Fluid Flow Using Small Bore Precision Orifice Meters
4. AGA Report No. 3: Orifice Metering of Natural Gas and Other Related Hydrocarbon Fluids, Parts 1, 2 and 3, 2013
5. ISO/TR 15377:2018 Measurement of fluid flow by means of pressure-differential devices – Guidelines for the specification of orifice plates, nozzles and Venturi tubes beyond the scope of ISO 5167
6. GOST 8.586.1-2005: Measurement of Flowrate and Volume of Liquid and Gas by Means of Standard Pressure Differential Devices—Part 1. Principle of Method of Measurement and General Requirements

### 7.6 Additional Information

For more information, refer to the following sources:

1. Miller, Richard W. *Flow Measurement Engineering Handbook* (3rd ed.). McGraw-Hill, 1996.
2. Blevins, R.D. *Flow-Induced Vibration*. United States, 1977.



# 8

## Transmitter Technology

	<b>Topic</b>	<b>Page</b>
8.1	Introduction	148
8.2	Main Components	148
8.3	Principles of Capacitive and Piezoresistive Pressure Measurement	149
8.4	Transmitter Types	151
8.5	Process Connections	155
8.6	DP Transmitter Ranges	158
8.7	Transmitter Specifications	160
8.8	Communication	163
8.9	Safety	165
8.10	Installation Considerations	166
8.11	Configuration	168
8.12	Calibration	170
8.13	Applicable Flow Meter Standards	171
8.14	Additional Information	171

## 8.1 Introduction

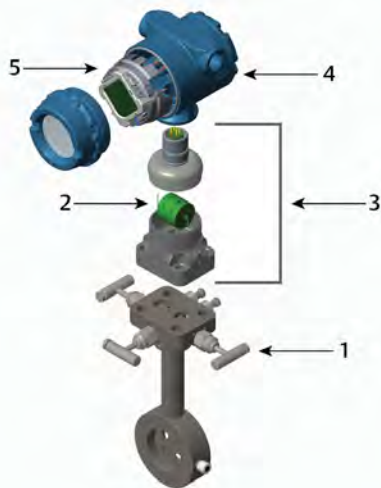
Differential pressure (DP) flow measurement requires two main components: the primary element that is installed in the pipe and the secondary element, or transmitter, that reads the DP signal. The transmitter serves as the intermediary between the differential pressure induced across the primary element by fluid flow and the signal that is sent to the plant's control system. Without a transmitter, there would be a substantial roadblock between creating the pressure difference and converting it into a useful value. Transmitter technology has improved noticeably over the years, and some transmitters are now able to measure process variables other than DP. Additionally, some transmitters can now directly calculate a compensated flow rate. These advancements have led to improved operation reliability and plant safety.

This chapter will cover the physical components of a transmitter, the sensors encased internally, and the electronics that transmit a signal to a control system. Installation considerations and basic configuration will also be highlighted. For more information about the primary element, see [Chapter 7](#).

## 8.2 Main Components

There are many components that make up a transmitter, all of which are critical to the design and functionality of the device. While all transmitters have some commonalities, there are certain components that are specific to a device depending on the measured variable. In general, pressure transmitters provide scalable solutions so that each transmitter can be optimized for its intended application, whether it is static pressure, differential pressure, or a flow measurement derived from multiple variables. [Figure 8.1](#) shows the major components of an integrated DP flow meter.

*Figure 8.1: An exploded view of an integrated flow meter.*



1. Process Connection – Integrated Compact Conditioning Orifice Plate and Manifold
2. Sensor
3. Module
4. Housing
5. Electronics

### 8.2.1 Process Connection

The process connection (shown as 1 in [Figure 8.1](#)) is used to connect the transmitter to the process. Common process connections include manifolds, impulse piping, and primary elements. A common example of a process connection used in DP flow is a manifold connected to a DP-producing primary element, which is directly inserted into the pipe and intrusive to the process.

### 8.2.2 Sensor

The sensor (shown as 2 in [Figure 8.1](#)) reacts to changes in the process by creating a signal, which is read by the electronics. Depending on the type of pressure measurement, the sensor will be capacitive or piezoresistive. These sensor types are discussed in detail in [Section 8.3](#).

It is important to note that some transmitters will also include static pressure and temperature sensors for multivariable measurement. The temperature value is used in conjunction with pressure measurement to provide a compensated flow value.

### 8.2.3 Module

The module (shown as 3 in [Figure 8.1](#)) houses the sensor. In some designs, the sensor includes a dedicated circuit board where the unique characteristics of the sensor, which are established during manufacturing, are stored. The modules can be hermetically sealed to ensure reliability, high accuracy, and stability. If the isolating diaphragms fail, the module has a secondary hermetic glass seal to prevent the process fluid from entering the transmitter housing or plant environment.

### 8.2.4 Housing

The housing (shown as 4 in [Figure 8.1](#)) is what protects the electronics of a pressure transmitter. Housings can come in various materials depending on the application. The transmitter housing can be intrinsically safe and explosion proof to protect the electronics from hazardous environments. It also provides terminations for communication wiring in the field.

### 8.2.5 Electronics

The transmitter electronics (shown as 5 in [Figure 8.1](#)) take the output of the sensor and turn it into a standard electronic signal. The most common transmitter output signal is 4-20 mA. This signal is used by the transmitter to communicate with the control system and is commonly paired with an overlaid HART® digital signal. The electronics of the transmitter can also output several different analog and digital protocols depending on the application requirement. Such signals and protocols include 1-5 V analog signal, FOUNDATION™ Fieldbus, PROFIBUS®, Modbus®, and WirelessHART®. In addition

to communicating with the control system, transmitter electronics can enable the use of a local display integral to the transmitter. For more information on communication protocols, see [Section 8.8](#).

## 8.3 Principles of Capacitive and Piezoresistive Pressure Measurement

Pressure is the amount of force applied over a defined area. In process industries, electronic pressure transmitters are used to convert process pressure into a digital or electrical signal, which can be sent back to a control room and/or displayed locally.

There are three types of pressure measurements: gage, absolute, and differential. The measurement type depends on how the low side of the transmitter is referenced. Every pressure sensor has a high side and a low side. Pressure on the high side minus pressure on the low side is equal to the output. In a gage pressure measurement, the low side is referenced to atmosphere. In an absolute pressure measurement, the low side is referenced to full vacuum (0 psia). In a differential pressure measurement, the low side is referenced to the high side.

Once a transmitter is installed, the pressure measurement starts at the transmitter's isolating diaphragm, which is a thin, flexible disc that is usually made of a metallic or ceramic material. This is the part of the transmitter that comes into direct contact with the process medium. The isolating diaphragm contains the process medium within the piping or tank and prevents fugitive emissions and leaks. As process pressure increases, the isolating diaphragm begins to flex. The change in pressure is then transferred from the isolating diaphragm to the transmitter sensor. It is common to have oil behind the isolating diaphragm, which is pushed to the sensor by the flexing isolating diagram. Not all transmitters have oil. In some cases, the transmitter sensor is either directly mounted

or mechanically connected to the isolating diaphragm.

The sensor of an electronic pressure transmitter physically responds to changes in input pressure and converts the physical movement into an electrical property, such as capacitance, voltage, inductance, or reluctance. Several types of sensors can be used with electronic pressure transmitters:

- Variable capacitance
- Piezoresistive
- Piezoelectric
- Variable inductance
- Variable reluctance
- Vibrating wire
- Strain gauge

For the purposes of this engineering guide, only the variable capacitance and piezoresistive sensors will be discussed in detail.

Once the sensor converts the pressure signal to an electrical property, the transmitter electronics convert it into a standard electronic signal as shown in [Figure 8.2](#). The pressure value can be communicated back to the control room using analog or digital signals or wireless technology.

Though electronic pressure transmitters are most common today, pneumatic pressure transmitters are still being used in facilities around the world. A pneumatic transmitter responds to an input pressure and transmits a proportionate, standardized pneumatic signal, which is typically 3–15 psig.

**Figure 8.2:** The pathway of a physical pressure measurement is converted into an electrical signal.

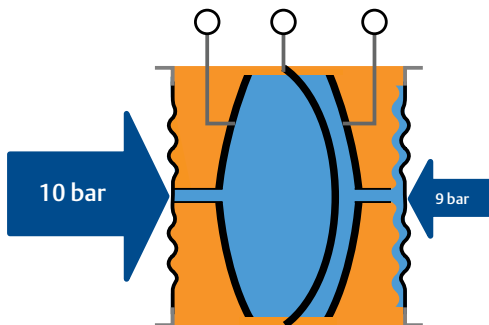


1. Transmitter Electronics
2. Transmitter Sensor
3. Isolating Diaphragm

### 8.3.1 Capacitive Sensor

The capacitive sensor was originally engineered by Rosemount Engineering Co., which was later acquired by Emerson, for aircraft applications. It was then introduced to the pressure market in 1969. Capacitive sensors are most often used to measure differential pressure. They consist of two plates and a central, flexible diaphragm. Two pressure chambers filled with oil are located between the plates and the diaphragm. As pressure increases and decreases, the flexible diaphragm moves between the two plates, which changes the capacitance across the oil-filled chamber. See [Figure 8.3](#).

**Figure 8.3:** The capacitive sensor diaphragm is deflected from its center resting position based on the applied pressure.



The capacitance in the sensor is represented by the following equation:

$$C = \frac{\epsilon A}{d}$$

Where:

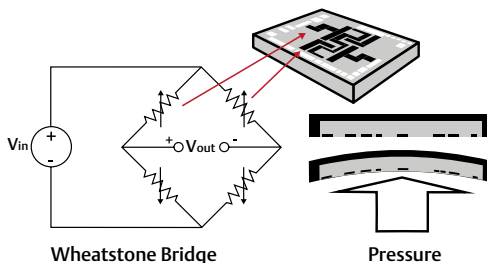
- $C$  Capacitance
- $\epsilon$  Dielectric constant of the oil
- $A$  Area of the plates
- $d$  Distance between the plates

As the distance between one plate and the diaphragm increases, the capacitance decreases. As the distance between the plate and diaphragm decreases, the capacitance increases. The capacitances from both sides of the sensor are then used to calculate a differential pressure through a proportional relation between DP and frequency generated by an inductive, resistive, capacitive (LRC) circuit. The capacitive sensor is widely accepted because of its inherent overpressure protection, which ensures that the sensor will not fail when exposed to extreme process pressures. For a closer look at how Emerson has used this technology to produce sensitive and accurate transmitters, see [Chapter 9](#).

### 8.3.2 Piezoresistive Strain Gauge Sensor

The piezoresistive sensor is silicon-based and consists of an array of resistors, called a Wheatstone bridge, which is etched on a silicon substrate. As pressure is applied to the sensor, the silicon flexes, which changes the resistance values as shown in [Figure 8.4](#). The change in voltage drop across the resistors of the Wheatstone bridge is used to calculate pressure.

**Figure 8.4:** The piezoresistive sensor, located on the top right, consists of an array of sensors called a Wheatstone bridge circuit. The bottom right image shows side views of a chip with and without pressure applied.



As with the capacitive sensor, the piezoresistive sensor must be separated from the process using an isolating diaphragm and oil-filled system. This type of sensor is most often used to measure static line pressure. Gage pressure transmitters are referenced against atmospheric pressure, and absolute transmitters are referenced against a full vacuum. The difference is that absolute pressure is equal to the gage pressure plus atmospheric pressure. Piezoresistive sensors are very popular in the marketplace due to their cost, size, and sensitivity for a wide range of pressure measurements.

## 8.4 Transmitter Types

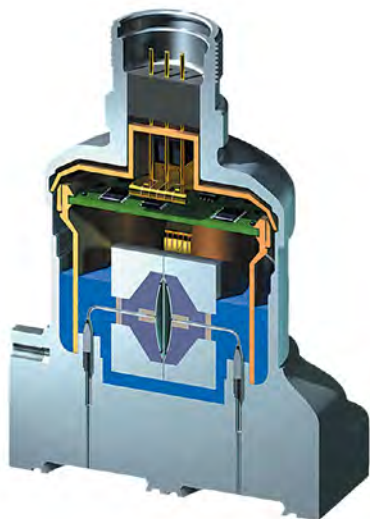
Although the root of pressure-based flow measurement lies within differential pressure measurement, several factors can play into the accuracy of the calculated flow value. Some applications require independent measurement of the fluid pressure and/or temperature to provide accurate flow rate measurement. This

can be done by using a single multivariable transmitter or a discrete pressure and temperature transmitter.

### 8.4.1 Single Variable DP Transmitters

A single variable DP transmitter measures DP only. A cross-sectional view of the measuring portion of a single variable transmitter is shown in [Figure 8.5](#). DP is created when a constriction, or primary element, is introduced into a fluid flow. A single variable transmitter has the capability to measure the created DP, turn it into an electrical signal, and then pass it through the transmitter's internal electronics, resulting in a meaningful and useful value for flow calculation. Many standards, such as ISO 5167 and ASME MFC-3M, dictate the notation and equation structure for DP flow.

**Figure 8.5: The inside view of a single variable DP transmitter, which uses a capacitive sensor as described in [Section 8.3.1](#).**



The equations<sup>1</sup> for calculating the volumetric and mass flow rate for an area meter are:

$$Q_v = NCY_1 d^2 E \sqrt{\Delta P / \rho}$$

$$Q_m = NCY_1 d^2 E \sqrt{\Delta P \rho}$$

Where:

$Q_v$	Volumetric flow rate
$N$	Conversion factor
$C$	Discharge coefficient
$Y_1$	Gas expansion factor
$d$	Diameter of the meter bore
$E$	Velocity of approach factor
$\Delta P$	Differential pressure
$\rho$	Fluid density
$Q_m$	Mass flow rate

However, since single variable transmitters are only able to measure differential pressure, they must use a simplified version of the flow equation. All variables other than DP are grouped together into a single constant,  $K$ , to create the equations:

$$Q_v = K_v \sqrt{\Delta P} \text{ and } Q_m = K_m \sqrt{\Delta P}$$

Where:

$$K_v = \frac{NCY_1 d^2 E}{\sqrt{\rho}}$$

$$K_m = \text{Value of } NCY_1 d^2 E \sqrt{\rho}$$

These simplified flow calculations can be used for applications where process conditions are nearly constant or vary only slightly. They can also be used for applications where the process fluid properties are not significantly impacted by a change in a specific parameter, as is the case with nearly incompressible liquids and minimal static pressure variations. In these situations,  $K$  will change by an inconsequential amount, and the calculated flow rate will be unaffected. A benefit of using a single variable transmitter for flow measurements is that it can provide a

<sup>1</sup>Miller, Richard W. *Flow Measurement Engineering Handbook* (3rd ed.). McGraw-Hill, 1996.



cost-effective solution with a simplified flow calculation.

However, in applications where the process conditions are changing, the dynamic variables represented by  $K$  will also change and potentially generate a significant error in the calculated flow rate. In this case, the fully compensated equation is needed. For example, as pressure and temperature change in a gas or steam application, variables such as density and gas expansion factor will also change, making the constant value for  $K$  inaccurate. An additional concern is the flow-dependent value of the discharge coefficient. Depending on the type of DP primary device and the range of flow, the discharge coefficient can change as much as 3%. To compensate for these dynamic changes, multivariable transmitters should be used.

### 8.4.2 Multivariable Transmitters

Multivariable (MV) transmitters are used to measure more than one variable within a single device. The most common configuration of these devices includes differential pressure, static pressure, and process temperature. The differential pressure and static pressure sensors are integrated into the same module. The temperature sensor can either be mounted in a separate location or integrated into the primary element. In both cases, the temperature sensor is wired into the transmitter housing. See [Figure 8.6](#) for an example of a sensor module that measures both differential and static pressure.

**Figure 8.6:** Multivariable transmitters house both the DP sensor and static pressure sensor in one device.



1. Differential Pressure Sensor
2. Static Pressure Sensor

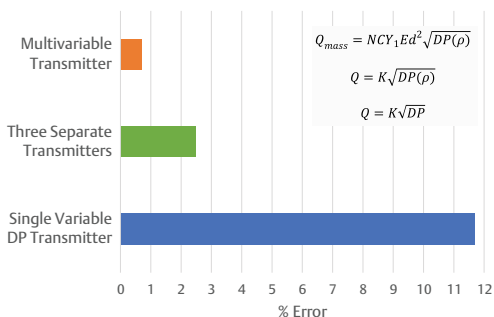
Multivariable transmitters may also include a built-in flow computer, which allows the calculation and output of a compensated flow rate. Since the flow computer is contained within the device, the transmitter can dynamically compensate for changing process conditions. As shown in [Section 8.4.1](#), the flow equation includes calculated variables such as discharge coefficient, gas expansion factor, bore size, velocity of approach, and density. Here are the effects that some of these can have on the flow calculation. Note that each of these effects is cumulative.

- The discharge coefficient,  $C$ , is the ratio of theoretical to actual flow rate for an area flow meter, and it accounts for viscous losses over the range of measurement. This value varies with the Reynolds number. For lower Reynolds numbers, a fixed  $C$  value can cause errors as high as 3%.
- The gas expansion factor,  $Y_1$ , corrects for the change in density of a gas as it accelerates to flow through or around the primary element. Using a constant value can lead to errors up to 2.5% for lower pressure, high-velocity gas flows.

- The bore diameter,  $d$ , of a differential-producing element can vary with changes in temperature by as much as 0.07% for a 100 °F (37.78 °C) uncompensated change in temperature. The effect on the flow rate due to the bore is 0.14%.
- For area meters, the velocity of approach factor,  $E$ , is a geometric parameter that accounts for the restriction presented to a flow by a primary element. It is directly dependent on the pipe diameter and meter bore, which expands and contracts with changes in temperature, creating errors up to 0.5% in addition to the 0.14% error mentioned previously.

By compensating for these variables, MV transmitters can accurately measure the flow rate. See [Figure 8.7](#) for an accuracy comparison between different ways of measuring flow using DP.

**Figure 8.7: Potential accuracy difference between three methods of measuring flow with DP. Superheated steam: normal flow at 13.4 lbs (6.1 kg/s) with a 16% pressure change and a 10% temperature change.**



Multivariable transmitters can improve the calculated flow rate accuracy for many types of applications, and they also simplify the installation and commissioning of the flow point since only one transmitter is needed to measure several variables. Rather than using three separate transmitters, three sets of wires/conduit, and multiple pipe penetrations, the MV transmitter combines all of this into one device. Since MV transmitters calculate flow, a separate flow computer is not needed. MV transmitters allow those calculations to happen in real time and directly output compensated flow rates.

As mentioned in [Section 8.4.2](#), the most common type of MV transmitter measures differential pressure, static pressure, and temperature. A transmitter can be selected based on the measurement types that are needed for the application. For example, maximum accuracy is achieved for gaseous processes and superheated steam measurements by incorporating differential pressure, static pressure, and temperature values into the compensated flow calculation. For fluids with consistent densities, which are typically liquids, only differential pressure compensation is needed. [Table 8.1](#) shows what measurements are recommended for certain applications.

**Table 8.1: Examples of recommended process measurements for flow calculation in common applications.**

Fluid Type	Measurement Type		
	Differential Pressure	Pressure (P)	Temperature (T)
Liquids with Little Change in Pressure and Temperature	X		
Liquids with Changing Temperature	X		X
Saturated Steam	X	P or T	P or T
Gas, Natural Gas, and Superheated Steam	X	X	X

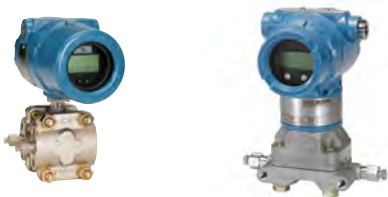
## 8.5 Process Connections

A process connection is the physical link between the transmitter's pressure sensor and the process fluid itself. Process connections include flanges, manifolds, DP flow primary elements, and seals. Careful selection of process connections is critical to the safety, accuracy, and reliability of the measurement. Factors such as fluid type, pressure, temperature, vibration, and ambient conditions need to be taken into consideration. For some types of transmitters, the process connection is bolted to the module at the factory, so it must be selected before ordering. The process connection type will also determine the installation orientation, ease of service, and maintenance required.

### 8.5.1 Instrument Flanges

A simple way to connect a transmitter to the process is with an instrument flange. A flange has a connection to the transmitter on one side and standard process taps on the other. Process flanges used on DP transmitters are available in two different styles: biplanar, also known as traditional, and Coplanar, as shown in [Figure 8.8](#). Transmitters with biplanar flanges have two flanges bolted together on either side of the sensing element. Since they have been around for a long time, the method of connecting to a biplanar flange and the spacing between the taps of 2.125-in. (54 mm) have become a standard. Many of the accessories, like manifolds, are made for this style of flange. The disadvantages with this style are the additional leak points and increased weight compared to Coplanar flanges.

**Figure 8.8:** Biplanar (left) and Coplanar (right) process flanges for connecting a transmitter to the process.



Emerson's Rosemount™ Coplanar™ flanges are a proprietary design that use a single instrument flange to connect the transmitter directly to the process. Due to this design, Coplanar flanges eliminate the additional leak points and weight of a biplanar flange. Coplanar flanges use a straight-through connection, which allows the transmitter housing to be mounted directly above the taps. For additional benefits of Emerson's Rosemount Coplanar platform, refer to [Chapter 9](#).

Specially designed flanges are needed to adapt to the DP flow meter primary element due to the unique Coplanar design. Traditional flanges allow Coplanar transmitters to connect to the same type of taps as a biplanar transmitter. This is beneficial for existing installations or to keep process connections consistent.

### 8.5.2 DP Manifolds





To make calibrations and maintenance easier, manifolds are used in place of, or in addition to, an instrument flange. A representation of common manifolds and flanges is shown in [Table 8.2](#).

An instrument manifold is a single block with several valves built into it that is designed to fit between the process pipework and an instrument. Additional examples of Coplanar manifolds are shown in [Figure 8.9](#).

**Figure 8.9:** Two different Coplanar manifolds.



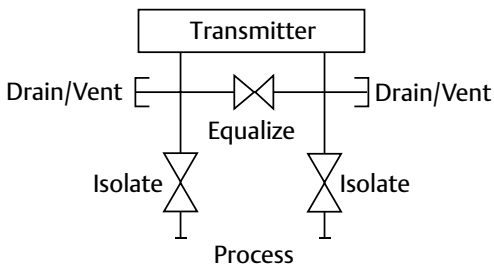
**Table 8.2: Common transmitter connection platforms.**

				
Process Connection Type	Traditional Flange	Conventional Manifold	Coplanar Flange	Coplanar Manifold
Valving Configurations	Drain vents	3-valve, 5-valve	Drain vents	3-valve, 5-valve
Benefits	Standard industry connection	Ability to connect to process by flange or threads	Reduced weight and size for flexible installation	Many valve options; can be used without a flange
Challenges	Large and heavy	Requires a traditional flange	Threaded-only process connection	Threaded-only process connection

Manifolds enable isolation of the instrument from the process and equalization of the pressure on both sides of the sensor, enabling a zero trim to be performed. Some designs allow venting of the pressure trapped inside, which brings the static pressure to atmospheric pressure at the instrument.

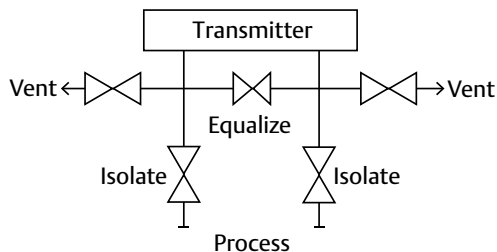
Manifolds can also contain valves used for calibration or blow down of the instrument lines. The most common valving configuration used with flow measurement is the 3-valve model with a valve diagram as seen in [Figure 8.10](#). The three valves allow for process isolation and equalization between the high- and low-pressure ports, ensuring that zero DP can be obtained for calibration and maintenance purposes. They also have drain and vent ports on both the low and high sides.

**Figure 8.10: A 3-valve manifold schematic.**



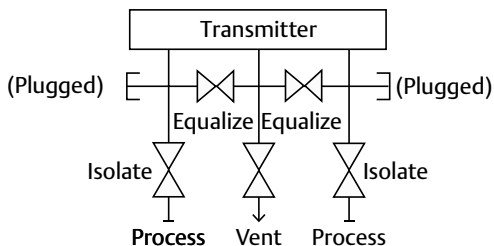
An alternative manifold configuration is the 5-valve. This manifold is commonly available in two different valve patterns: one that replaces the drain and vent ports with valves and one that introduces an additional equalize valve used specifically in natural gas applications. The standard 5-valve captures 100% of the vented and drained process. See [Figure 8.11](#) for the valving pattern.

**Figure 8.11: A 5-valve manifold schematic.**



The 5-valve natural gas manifold has an additional equalize valve between the high and low ports, and the two equalize valves are separated by a common vent valve. This configuration ensures that there will be no leakage through the equalization valve and is used when costly process gases need extra levels of measurement reliability. While this specific valving configuration is referenced as a natural gas manifold, it can be used in other applications. The 5-valve natural gas pattern is shown in [Figure 8.12](#).

**Figure 8.12:** A 5-valve natural gas manifold schematic.



2-valve manifolds exist for static pressure measurement purposes, but these are not used in flow measurement and will not be discussed.

### 8.5.3 Primary Elements and Integrated DP Flow Meters

Recent technology advancements in DP flow primary element design eliminate the need for fittings, tubing, valves, adapters, and manifolds through the use of integrated flow meters. Integrated flow meters reduce the complexity of connecting to the process by incorporating all of this equipment into one system as shown in [Figure 8.13](#). Some of the benefits of integrated flow meters are reduction of leak points and ease of installation and maintenance. Also, because an integrated flow meter is configured for the application, no additional steps, except for a zero trim, are required to commission the flow point.

**Figure 8.13:** Flow meter assemblies using the same transmitter. Many flow meter configurations are possible due to the wide range of available primary elements. Clockwise from top left: Rosemount 3051SFA Annubar, Rosemount 3051SFC Compact Conditioning Orifice, and Rosemount 3051SFP Integral Orifice Flow Meter.



### 8.5.4 Seals

In applications with extreme process conditions such as high temperatures, corrosive materials, and dirty process fluids, seals can help isolate and protect the transmitter. A seal is a secondary fluid-filled diaphragm system between the transmitter-sensing diaphragms and the process. Seals can either be directly mounted to the transmitter or use a length of capillary to physically mount the transmitter at a remote location. An example of a balanced seal system is shown in [Figure 8.14](#). Seals can also be used as another way to eliminate impulse piping and reduce leak points. Seals must be specified for the process temperature and selected for the range of differential pressure. In general, it is beneficial to use a larger diaphragm as they are more flexible, resulting in a more sensitive system. Seals increase the response time for a DP flow meter system, so they should not be used for control applications where fast response to flow rate changes are needed.

**Figure 8.14:** Seals can be used as a way to isolate and protect a transmitter in extreme conditions.



### 8.6 DP Transmitter Ranges

Selecting the correct differential pressure range is a key part of choosing the optimal transmitter for DP flow applications. Every differential pressure transmitter has an upper range limit (URL) and lower range limit (LRL). For most DP flow applications, the LRL is typically set to zero. Accurate flow measurements occur only within these limits. While it may be concerning when process conditions exceed the measuring limit of a transmitter, the device itself can often withstand differential pressures many times higher than the URL without damage. The static pressure limit that a transmitter can withstand without damage is known as the overpressure limit and is often thousands of psi higher than the working pressure limit. For example, a Rosemount 3051S MultiVariable™ transmitter with a 0 to 1000 inH<sub>2</sub>O (0 to 249 kPa) range has an overpressure limit of 3626 psi (250 bar). Check the product data sheet to determine the specific upper and lower range capabilities for the transmitter, as well as if there is an additional DP overpressure limit.

#### 8.6.1 DP Transmitter Rangedown

The rangedown of a DP transmitter defines how the span (i.e., the configured full scale of the transmitter output) can be changed. The

rangedown of an instrument is expressed as the upper range limit divided by the minimum span. The minimum span is the smallest range that the transmitter can be set to.

#### Example:

A DP transmitter that has an upper range limit of 1000 inH<sub>2</sub>O (0 to 248.8 kPa) and a rangedown of 100:1 can be set up to accurately measure DP with a span from 0 to 10 inH<sub>2</sub>O (0 to 2.49 kPa) up to a span of 0 to 1000 inH<sub>2</sub>O (0 to 248.8 kPa).

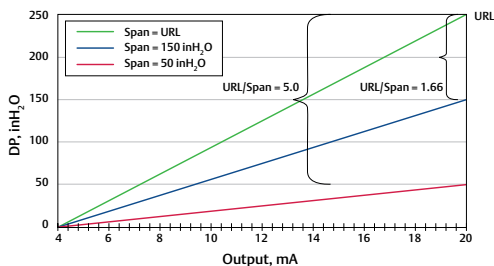
See [Table 8.3](#) for a sample of DP transmitter range limits and minimum spans.

**Table 8.3:** A sampling of DP pressure ranges for the Rosemount 3051S MultiVariable transmitter.

DP Pressure Range	DP Upper and Lower Range Limit	Minimum Span
1	-25 to 25 inH <sub>2</sub> O (-6.2 to 6.2 kPa)	0.5 inH <sub>2</sub> O (0.1 kPa)
2	-250 to 250 inH <sub>2</sub> O (-62.2 to 62.2 kPa)	1.3 inH <sub>2</sub> O (0.3 kPa)
3	-1000 to 1000 inH <sub>2</sub> O (-248.8 to 248.8 kPa)	5.0 inH <sub>2</sub> O (1.3 kPa)
4	-150 to 150 psi (-10.3 to 10.3 bar)	1.5 psi (0.10 bar)
5	-2000 to 2000 psi (-137.9 to 137.9 bar)	20.0 psi (1.38 bar)

The re-spanning of a DP transmitter can be done using a handheld communicator or configuration software. It allows the ability to stock a single DP transmitter range and then configure units for specific applications when they are needed. Since accuracy is often a function of calibrated span, the transmitter will need to be re-calibrated at the new upper range value to achieve the instrument's reference accuracy. [Figure 8.15](#) shows how this looks graphically for a DP transmitter with a 250 inH<sub>2</sub>O (0 to 62.2 kPa) and a URL spanned down to 150 and 50 inH<sub>2</sub>O (37.3 and 12.4 kPa). It is best to have the transmitter calibrated at the factory to the intended operating range in order to achieve maximum accuracy for an application. More information on calibration can be found in [Chapter 11](#).

**Figure 8.15:** A changing DP transmitter span with a URL of 250 inH<sub>2</sub>O (62.2 kPa) and a span of 150 and 50 inH<sub>2</sub>O (37.3 and 12.4 kPa).



When selecting a DP transmitter for a flow application, rangedown is typically not a factor. It is more important to select a range where the URL is equal to or greater than the differential pressure reading at the maximum flow rate.

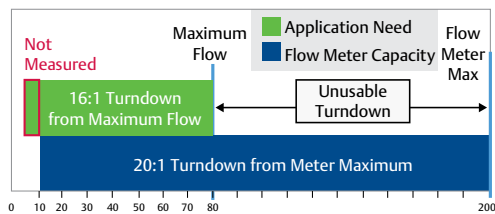
### 8.6.2 Flow and DP Turndown

Flow turndown is defined as the ratio of the maximum flow rate in an application divided by the minimum flow rate. This term is useful in describing the required measurement range for a flow application. For example, if it is required to measure from 352 gal/min (80 m<sup>3</sup>/hr) to 22 gal/min (5 m<sup>3</sup>/hr), the required turndown would be 352/22 or 16:1.

Flow meter manufacturers also use flow turndown to describe the measurement capability of their devices and the range over which flow meter performance specifications apply. In this case, the maximum flow rate is typically the highest flow rate that the flow meter can measure. Because of this, there can be a big difference in what the flow meter manufacturer specifies as the turndown of their device and what is required by the application. For example, a flow meter manufacturer may promote a turndown of 20:1 for their flow meter using a meter maximum of 881 gal/min (200 m<sup>3</sup>/hr). This flow meter would not be able to measure the application described in the previous paragraph because a 20:1 turndown from an 881 gal/min (200 m<sup>3</sup>/hr) meter maximum is only 44 gal/min (10 m<sup>3</sup>/hr). Even though the published flow meter turndown is greater than the application

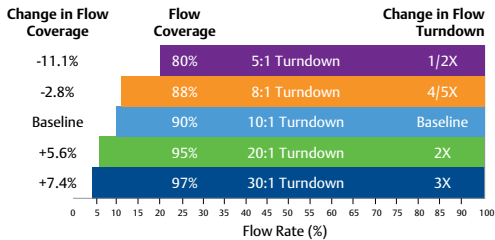
turndown requirement, the flow meter might not operate down to the minimum flow rate of 22 gal/min (5 m<sup>3</sup>/hr). Also, a portion of the flow meter capability, namely measuring flows from 352 gal/min (80 m<sup>3</sup>/hr) to 881 gal/min (200 m<sup>3</sup>/hr), is not required by the application. This is described as unusable turndown. These relationships are illustrated in [Figure 8.16](#). Note that orifice plates are typically sized for the maximum flow rate required by the application, so that the limitations of the primary element and maximum flow rate align.

**Figure 8.16:** Example of a meter with higher turndown than is required by the application, but the meter is not a feasible selection due to unusable turndown.



Flow coverage is an important consideration when comparing different flow meters. Flow coverage gives an indication of the measurable flow range of the device over the maximum flow range when the minimum flow is considered to be zero. Flow coverage also includes the impact of low flow cut-off inherent in some technologies, where a certain minimum flow rate is required before any measurement will be provided. DP flow technology will typically provide an indication of flow even at very low rates, although the measurement will not be accurate to within specification until the flow rate is above the flow meter minimum specified flow rate. The relationship between flow coverage and turndown is illustrated in [Figure 8.17](#). As shown in the figure, a flow meter with 30:1 turndown provides 3X the turndown over a flow meter with 10:1 turndown but only a 7.4% increase in flow coverage.

**Figure 8.17: A graphical representation of attainable flow coverage with increasing turndown values.**



Since a differential pressure transmitter is required for DP flow, flow turndown is often confused with DP turndown and DP rangedown. DP turndown is defined as the differential pressure reading at maximum flow rate divided by the differential pressure reading at minimum flow rate. Due to the square-root relationship between differential pressure and flow, an application requiring 10:1 flow turndown will require 100:1 DP turndown. The relationship across some flow turndowns is shown in [Table 8.4](#).

**Table 8.4: Relationship between flow turndown and DP turndown. Note that the DP turndown is equivalent to the square of the flow turndown.**

Flow Turndown	DP Turndown
1:1	1:1
2:1	4:1
8:1	64:1
10:1	100:1
20:1	400:1

DP rangedown is defined as the URL of the DP transmitter divided by the minimum span allowed by the device. For flow applications, differential pressure transmitters are typically calibrated from zero to the differential pressure reading associated with maximum flow. The DP rangedown is typically not a factor in selecting a DP transmitter for flow applications. It is most important to select a range where the URL is equal to or greater than the differential pressure reading at maximum flow.

When an application flow rate varies widely and is measured with a transmitter that is incapable of a high turndown, primary elements must be changed or multiple transmitters must be used for a single line. Using a transmitter capable of high turndowns allows for measurement of periodically changing flow rates. These are generally more drastic than regular variation in a process flow and are often tied to differing maximum and minimum rates associated with seasonality. An example that requires high turndown capabilities is in district heating where steam is more heavily consumed in the winter than the summer months.

## 8.7 Transmitter Specifications

Transmitters must meet the minimum specifications required by the target application. The interpretation of transmitter specifications is important because they determine whether the specific device is going to perform well in a given application. Every transmitter will have a specifications document that is supplied by the manufacturer. Specifications include performance, physical, and functional details, and they tie into the overall cost.

### 8.7.1 Performance Specifications

Due to the need for measuring a wide range of DP at potentially high static pressures and varying ambient conditions, DP transmitter specifications must include how these conditions impact the performance of the transmitter. Additionally, the specification will generally indicate the maximum time the unit will maintain its stability before it requires service. If the performance does not meet the minimum requirements, the transmitter might not be a good fit for the application. Overall performance is defined by the Total Probable Error (TPE). TPE is the accuracy of the instrument in installed conditions. TPE is made up of three things:

1. Reference accuracy
2. Ambient temperature effects
3. Line pressure effects



These three components are then calculated using the root sum squares formula shown in [Figure 8.18](#).

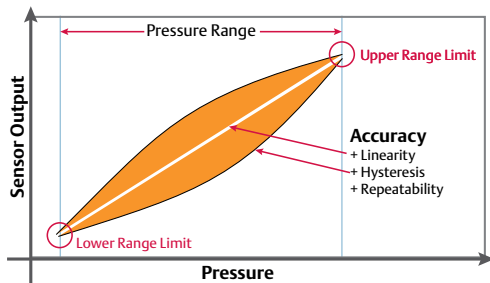
**Figure 8.18: Total probable error accounts for reference accuracy, ambient temperature effects, and line pressure effects.**

$$\text{Total Probable Error} = \sqrt{\underbrace{(\mathbf{X}_r)^2}_{\substack{\text{Reference Accuracy} \\ \text{Accuracy at Calibrated Range}}} + \underbrace{(\mathbf{X}_t)^2 + (\mathbf{X}_p)^2}_{\substack{\text{Ambient Temperature Effect} \\ \text{Line Pressure Effect} \\ \text{Installation Effects on Accuracy}}}}$$

### 8.7.1.1 Reference Accuracy

The first component in TPE is reference accuracy. Along with the basic function and features of transmitters, accuracy is the most common specification. For DP transmitters, accuracy is defined as the probable limit of an instrument error to a known and traceable reference. Reference accuracy is the transmitter performance that would be achieved on a bench check in a laboratory. This performance specification defines the limits that errors will not exceed when tested under reference operating conditions. Accuracy is typically expressed as a percentage of calibrated span, but it can also be expressed as a percentage of the upper range limit or a percentage of the displayed measurement or reading. This specification includes errors due to linearity, hysteresis, and repeatability as shown in [Figure 8.19](#).

**Figure 8.19: The reference accuracy specification incorporates linearity, the effects of hysteresis, and repeatability.**



Linearity is calculated as the maximum deviation between the average error curve and the designated straight line. Hysteresis is a dependence of the state of the system upon its history. Hysteresis is calculated as the difference in readings at a set point when the set point is approached from different directions in the test cycle. Repeatability is the ability of a transmitter to output the same values when operating under the same process and environmental conditions. Refer to [Chapter 7](#) for more information on flow meter performance.

### 8.7.1.2 Ambient Temperature Effects

Temperature error can result from changes in either process or ambient temperatures. In general, process temperatures are more stable while ambient temperatures tend to fluctuate. Transmitters are factory calibrated at room temperature. If a transmitter operates at a different ambient temperature, the electronics perform differently, and a measurement error may result. This error is called ambient temperature effect. Temperature effect, unless otherwise stated, is assumed to include both zero error and span error. Generally, transmitters are tested for ambient temperature changes and are compensated to reduce these effects using an on-board temperature sensor in the electronics enclosure.

### 8.7.1.3 Line Pressure Effects

Line pressure effect errors occur when the characteristics of the sensor are altered under static pressure. This effect, which only applies to DP pressure measurement, is an error that results due to the forces of static pressure applied to the sensor. Generally, there are two performance calculations: the effect at zero and the effect at span. The line pressure effect at zero can be eliminated by completing a zero trim at line pressure whereas the span effect is always present.

### 8.7.1.4 Stability

Stability is a transmitter's change in output given a fixed input as a function of time. Limited

variability in the stability of the transmitter allows for less frequent calibrations. Better long-term stability results in reduction of periodic maintenance and repairs, which leads to reduced total cost of ownership.

### 8.7.2 Physical Specifications

Physical specifications include the mechanical attributes of an instrument, such as the sensor, flange, and housing material. They can help determine which instrument will meet the operation and process environment requirements. Many transmitter vendors offer multiple materials for isolation diaphragms, electronics enclosures, fill fluids, and other accessories. Isolating diaphragms are usually made of 316 stainless steel (316SS), which is appropriate for most applications. However, other materials are available for special applications that use harsh process fluids. Nickel-based alloys such as Alloy C-276 and Alloy 400 are typically used in high-salinity applications, like sea water, or when the process contains alkalides or high-chloride content. Additionally, tantalum can be used with strong acids. Gold-plated isolating diaphragms may also be used when hydrogen permeation is possible.

Electronics enclosures are most commonly made from painted aluminum, which provides good corrosion resistance. However, the amount of corrosion resistance depends on trace element contents, such as copper in the aluminum and the quality of the paint used. Copper-free or ultra-low copper grades improve the corrosion resistance of aluminum by removing most of the copper from the alloy. Stainless steel remains the best electronics enclosure for corrosion resistance. Some transmitters use polymer housings when wireless communication protocols are used to allow the antenna to be internally installed, which eliminates the need for external antennas. These housings are the lightest weight but are not suitable for explosion-proof hazardous locations.

Pressure transmitters typically contain a fill fluid to hydraulically transfer the pressure reading from the isolating diaphragms to the pressure sensor. This fill fluid must be compatible with the process media in the event that the diaphragm is compromised, causing interaction between the fill fluid and the process media. The different categories of fill fluids are characterized as:

- Standard fill fluids are typically light silicone oils.
- Inert fill fluids are also available for services like oxygen or applications where silicone fluids are banned due to product contamination.
- Hygienic fill fluids or fluids rated for food contact are also available.

The final physical specification is weight. The weight of the transmitter and flow meter must be determined so that the assembly can be installed properly and safely be supported by the pipe or platform where it will be installed.

### 8.7.3 Functional Specifications

Functional specifications define the exposure limits and conditions that a transmitter can withstand while continuing to perform within required setpoints. The most basic functional requirements include adequate power available and a method of device communication. Additionally, the device should be able to withstand all pressure and temperature constraints and limitations. Pressure limits are usually specified as the maximum working pressure and burst pressure. The maximum working pressure is the greatest long-term safe process pressure that the transmitter can endure. Burst pressure is the pressure at which failure or destructive distortion occurs. Temperature limits are usually specified for both ambient and process temperatures. Functional specifications must be within these functional limits to ensure no damage occurs to the sensors, fittings, seals, and electronics.

All possible specifications should be considered when selecting a transmitter to ensure that

safety and performance goals are met. Once specification requirements have been met, consider transmitter diagnostics that assist with safe and reliable operation. See [Chapter 9](#) for more information on advanced transmitter and process diagnostics.

### 8.7.4 Transmitter Costs

Total cost for owning a transmitter includes purchase costs, as well as installation, operation, and maintenance. In general, optional features, materials, approvals, and performance affect the cost of a transmitter. The transmitter type will also affect the total ownership costs. For example, multivariable transmitters are going to have a higher purchase cost than single variable transmitters. However, when compared to using three separate transmitters, a multivariable transmitter is going to have lower maintenance, installation, and operating costs. When measuring DP flow, the transmitter is only one component, and the other flow meter components should also be considered. See [Chapter 7](#) for more details about flow meter costs.

## 8.8 Communication

Communication is the transmission of information between two or more points (e.g., transmitter and controller) without alteration of sequence or structure of the information. There are two main communication protocols: analog and digital. These communication technologies tie process control instruments together with host systems, network masters, and other devices. The field of communication technology is constantly evolving, and the accuracy and utility of device communication continues to improve dramatically.

Sensor equipment does not generally produce usable signals on its own. Typically, a sensor will emit or regulate a small voltage or current. The fundamental job of communication technology is to transform the raw signals from transducers into intelligible values that can be transmitted

to other locations such as a control room or maintenance shop.

Advancements in communication have provided access to and use of information that was previously not available, resulting in new opportunities for efficiency. Some of these advancements include:

1. Remote device maintenance — Technicians can interact with, test, and configure field devices from remote locations using two-way digital communications.
2. Transmitter and process diagnostics — Diagnostics can be monitored, and problems can be reported back to a control room or maintenance shop.
3. Control in the field — Network traffic can be handled by transmitters in the absence of a control host. Furthermore, transmitters and other devices can be linked together in complex, decision-making networks.

For more information about process and transmitter diagnostics, see [Chapter 9](#).

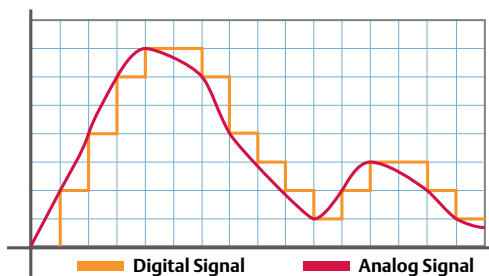
### 8.8.1 Analog Signals

Analog signals represent the value of a parameter by the magnitude of the signal. Analog signals change in non-discrete steps—any value within the minimum to maximum range of the device is possible. The 4-20 mA signal is the most prevalent analog signal in the process control industry. This signal varies the current of an electrical signal to convey information. The 4-20 mA range represents the normal 0–100% range of the value being transmitted. Failure/alarm conditions are transmitted using mA values outside this normal range (i.e., signals below 0-4 mA or above 20 mA). Using 4 mA as the lowest value in the range is primarily beneficial for diagnostic purposes. Transmitters generally are ranged to output 4 mA when the process condition is in a zero state (i.e., no flow).

### 8.8.2 Digital Signals

Digital signals are signals that represent the value of a parameter by coding a number using the binary system in a series of on/off pulses. A digital signal does not continuously change like an analog signal; digital signals jump directly from the on state (1) to the off state (0). For example, consider an FM radio. The increments on an FM radio can be tuned to discrete intervals, but the tuning cannot fall in between these set steps. If the radio was set to 99.5, the next possible channel would be 99.6 as the radio is unable to settle on a value between the two. While an FM radio uses step sizes less than one, it is an appropriate example when considering the concept of discrete interval changes. Since process values are inherently analog, transmitters must obtain a digital process value by sampling the analog process value many times per second, which causes the value to step to discrete values. *Figure 8.20* illustrates the concept of digital process values.

*Figure 8.20: The visual difference between analog process value and the created digital signal from sampling the analog signal.*



#### 8.8.2.1 Advantages of Digital Communication

Digital communication technology offers significant advantages over simple analog technology. Some of the most important advantages of digital communication include:

- Decreased wiring costs
- Remote device communication
- Improved accuracy in data transmission
- More available information from a single device

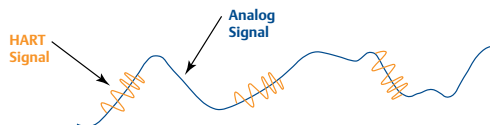
The process control industry uses a wide variety of digital protocols for device communication. Five of the most common protocols are:

1. HART
2. FOUNDATION Fieldbus
3. PROFIBUS
4. Modbus
5. *WirelessHART*

#### 8.8.2.2 HART

The digital Highway Addressable Remote Transducer (HART) protocol can communicate across legacy 4-20 mA instrumentation wiring by treating the 4-20 mA signal as a carrier and overlaying smart protocol communications on the carrier signal. This is shown in *Figure 8.21*. It is widely used in legacy systems, since it uses existing instrumentation wiring and a standard 4-20 mA signal for the primary variable.

*Figure 8.21: The HART signal is overlaid on the analog signal.*



#### 8.8.2.3 FOUNDATION Fieldbus

FOUNDATION Fieldbus is a two-way, all digital, multi-drop serial communications protocol designed as a base level network for factory automation. It performs complete loop functions of sensing, control, and actuation, all on the communications bus. This protocol uses input/output (I/O) function blocks to interface with and represent both the physical world and the information world. Resource blocks define the physical device, such as transmitter, valve, or similar device. Transducer blocks deal with sensors and actuators, which bridge the physical world and the information world. I/O blocks make transducer block information, which is available on the bus, usable by other blocks for monitoring or control. Function (i.e., application) blocks

accept one or more inputs, perform calculations, and produce an output. Blocks can be combined to provide a broad spectrum of functionality.

### 8.8.2.4 PROFIBUS

PROFIBUS, like FOUNDATION Fieldbus, is a fieldbus—a two-way, digital-only communication protocol. The main differences between PROFIBUS and fieldbus are the protocol design, network structure, and network management. PROFIBUS is fundamentally designed to meet high-speed factory automation needs. There are several different forms of PROFIBUS, but PROFIBUS-PA (Process Automation) is the only one designed for process control.

### 8.8.2.5 Modbus

Modbus is a digital master slave device communications protocol. Modbus is primarily used to communicate control and monitor data. Each device on the Modbus network has an address, and its data is mapped to specific registers within the device. A Modbus master, such as a Remote Terminal Unit (RTU), polls each device querying for its measured data located and stored in the device registry. These master programs are highly sophisticated and can manage data and traffic along the Modbus network to ensure a continuous flow of pertinent data.

### 8.8.2.6 WirelessHART

WirelessHART leads as the primary wireless protocol in terms of number of devices and overall adoption rate for industrial process control. Wireless industrial communications are ideally suited for applications that involve instrumentation in hard-to-reach or unsafe areas. The standard that wireless protocols follow is IEEE 805.15.4, which defines low power, low data rate, and short-range networking that provides physical and medium access control layers. Wireless protocols offer many advantages over traditional wired systems including:

- Eliminate wiring/conduit costs
- Reduced I/O costs
- Decreased installation time and costs
- Gather data from hard-to-reach areas

## 8.9 Safety

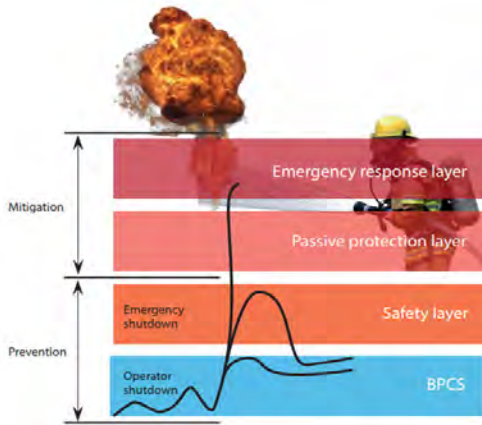
The potential for catastrophic failure is part of nearly every industrial process. Toxic substances must be contained, heat and reactions must be controlled, and flammable substances protected from ignition. Failures can cause personnel fatalities or injuries, environmental damage, and/or financial losses. Therefore, safety instruments and safety layers are critical.

### 8.9.1 Safety Instrumented Systems

There are two different types of systems in a plant environment. The first is the control system, whose main purpose is to keep the plant running and optimize profits. The other system is the Safety Instrumented System (SIS). See [Figure 8.22](#). If needed, the safety system is designed to override the control system and shut down the plant to prevent accidents. Safe plant operation requires proper hazard prevention and mitigation.

Consider an example of a highly reactive fluid flowing through a pipe. Without proper prevention and mitigation, the fluid pressure could reach a dangerous level, causing the pipe to burst. See [Figure 8.22](#).

Figure 8.22: An example of a safety system.



In this example, a Basic Process Control System (BPCS) keeps the flow at normal conditions by controlling temperature and pressure. If the flow deviates from predetermined safe operating conditions, then the first prevention layer, which is operator intervention, will be triggered. This may be an audible alarm that sounds to tell the operator to manually shut a valve to stop the flow. If this does not work, the SIS layer would reduce the pressure before the pipe bursts.

If these prevention steps fail, then mitigation begins. The first mitigation layer could be to open a pressure relief valve before the pipe ruptures. The next layer might be some type of bypass where the fluid can be diverted from the main process. If this fails or if process fluid is somehow released, there is the final mitigation layer, which is plant and emergency response. This layer ensures that vapor released by the pressure relief valve does not cause further damage and minimizes contamination to the environment.

An SIS-certified transmitter will properly measure and trigger any alarms based on the process conditions that it measures. Should the process conditions fall outside the safe parameters measured by the transmitter, the transmitter will signal an alarm to change the process before any danger could occur. In an SIS application, certified instrumentation is required to meet the necessary Safety Integrity Level (SIL).

### 8.9.2 Safety Integrity Level

In setting up safety layers, organizations analyze the likelihood of the occurrence of specific events, which is called a hazard and operability analysis (HAZOP). This analysis sets risk reduction factors that quantify how much effort must be applied to keep a given event from occurring. The risk reduction factor determines the SIL required. [Table 8.5](#) shows the four SIL levels.

Table 8.5: The probability of failure for different safety integrity levels.

Safety Integrity Level	Probability of Failure on Demand	Risk Reduction Factor
SIL 1	$\geq 10^{-2}$ to $< 10^{-1}$	100 to 10
SIL 2	$\geq 10^{-3}$ to $< 10^{-2}$	1,000 to 100
SIL 3	$\geq 10^{-4}$ to $< 10^{-3}$	10,000 to 1,000
SIL 4	$\geq 10^{-5}$ to $< 10^{-4}$	100,000 to 10,000

The IEC 61511 standard is used in the process industry to define the requirements for design, implementation, and operation of SIS.

### 8.10 Installation Considerations

Measurement accuracy depends on proper installation of the transmitter, flow meter, and/or impulse piping. Proper installation location is dictated by several factors, including industry regulations, national restrictions, ambient conditions, and local codes. Understanding the different technologies and techniques available to meet these codes and regulations is a requirement. Correct installation is possible only by examining the site, both physically and through drawings and specifications. Only then can the most effective configuration be defined, one that combines piping, connections, instruments, materials of construction, and electrical constraints. It is also important to keep in mind the need for easy access, personnel safety, and practical field calibration.

Process conditions such as process fluid temperature, static line pressure, and physical properties of the working process fluid can affect the method and location of the transmitter installation. Ambient temperatures are also important to consider, as varying temperatures may impact the quality of measurement. For more information on flow meter installation, see [Chapter 10](#).

### 8.10.1 Process Temperature

If the process temperature exceeds the limits of the transmitter, other mounting practices should be used, such as impulse piping or remote diaphragm seals. Without proper installation, high temperatures can affect the transmitter electronics, thereby causing reduced performance or unit failure.

### 8.10.2 Ambient Temperature

Ensuring that measurement instruments operate within their temperature limits under all ambient weather conditions requires considering three important and related variables: mounting location, protective measures, and cost. The location of the instrument with respect to the process and the environment is often the easiest way to control instrument temperature. If mounting location alone is not adequate to control the temperature, protective measures can be used. Some of these protective measures include using auxiliary sun shades, enclosures, and heat tracing. However, protective measures result in higher instrument and/or installation costs.

The mounting location of an instrument is the most cost-effective way to protect against high temperatures. Consider the location of the instrument in regard to the direction of the sun. Always avoid direct sun if possible. If instruments must be mounted in direct sun, enclosures or auxiliary sun shades should be installed.

In extremely cold environments where the mounting location alone is not enough to provide freeze protection, four options are available:

1. Instrument enclosure — A simple insulated box placed around the transmitter.
2. Heat tracing — Electrical conductors or steam pipes are used to heat pipes and enclosures.
3. Close coupling — This configuration utilizes heat from the process to keep components at operating temperature. In applications where close coupling is not possible, an enclosure and a heat trace may be necessary.
4. A combination of the three.

### 8.10.3 Process Pressure

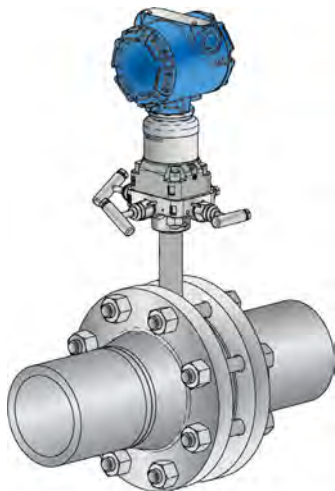
The pressure class of the system is another installation consideration. Make sure that the instrument being installed has the appropriate pressure rating. The pressure rating indicates the maximum allowable pressure the instruments can withstand under normal operating conditions. Standard flange ratings include Class 150, 300, 600, 900, 1500, 2500, and 4500. To determine the appropriate pressure class for an application, look at the design pressure and temperature, and materials of construction.

### 8.10.4 Direct Mount and Remote Mount Configurations

Ensuring that a transmitter is mounted in the correct manner is crucial to obtaining a quality measurement. Even the most accurate and reliable transmitter will read poorly if it is installed incorrectly in the process. For both direct mount and remote mount installations, it is necessary to consider the orientation of the transmitter as well as the process fluid characteristics. For more details on specific installation configurations, see [Chapter 10](#).

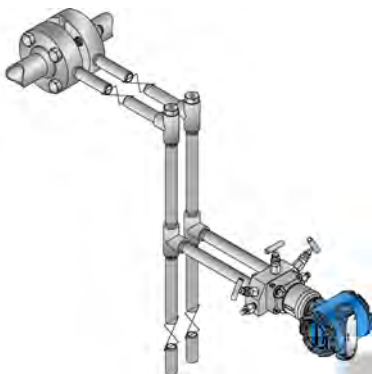
DP flow measurements can be obtained using direct or remote mounting configurations. In a direct mount configuration, the transmitter is mounted directly to the primary element as shown in [Figure 8.23](#).

**Figure 8.23:** A direct mount transmitter for gas flow measurement.



In a remote mount configuration, the transmitter is mounted separately from the primary element and connected using impulse tubing or piping as shown in [Figure 8.24](#). It is important to keep in mind space and complexity limitations when selecting the installation type.

**Figure 8.24:** A remote mount transmitter for steam measurement.



In general, impulse piping takes up much more space than direct mount transmitters, making direct mount transmitters a better choice in tight spaces. Impulse piping also requires a more extensive installation.

There are benefits to remote installations. When process temperatures exceed the limits of the transmitter, impulse piping can be used to dissipate heat. For example, in high temperature applications, a common rule of thumb is that one foot of uninsulated impulse piping will typically cool down the process fluid by 100 °F (37.7 °C). Additionally, remote mounting allows for ease of transmitter maintenance and local indication at grade. See [Chapter 10](#) for more information.

### 8.10.5 Additional Considerations

There are many additional factors to consider when installing transmitters, including mounting orientation, wiring best practices, and commissioning. Transmitters may be mounted in a variety of orientations depending on whether the process fluid type is liquid, gas, or steam. These guidelines apply to both remote mount and direct mount installations. Additionally, it is important to understand the wiring practices that are common in process control applications. This includes a 2-wire or a 4-wire installation, the different types of wires used, conduits and cable trays, transient surge protection, and grounding. See [Chapter 10](#) for a more in-depth look at these additional flow meter installation considerations.

## 8.11 Configuration

In DP flow, configuration includes both the device configuration and the flow computer configuration. Transmitters are often configured with default settings during manufacturing, and subsequent configuration of a transmitter allows the unit to be tailored to an individual application. Transmitters can be custom configured by the manufacturer or by the end user once a unit is purchased and received. Every transmitter is unique, so always reference the transmitter manual before configuring the transmitter.

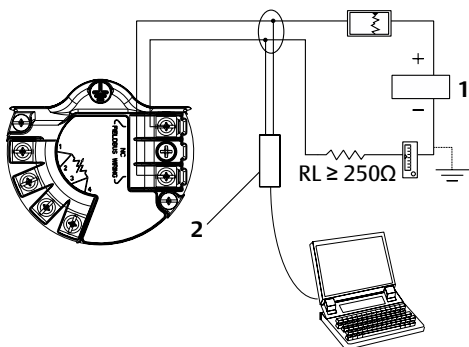
In general, there are two main methods of configuring instruments: a bench configuration prior to installation and commissioning after



installation. Transmitters can also be configured directly from the manufacturer's factory, which eliminates the need for a full configuration on-site. Configuration can be done through portable handheld devices, personal computers, or control systems. These tools provide flexibility in choosing what the best configuration tool is for a given application or process environment.

Figure 8.25 shows an example of a computer connected to a transmitter with a HART protocol for configuration.

**Figure 8.25: An example of a computer connected to a transmitter for configuration.**



1. Power Supply
2. HART Modem

When configuring the transmitter, take these safety considerations into account:

- Covers often need to be removed to configure the transmitter, which should only be done in non-hazardous and approved locations.
- Verify that the transmitter is set up correctly so that accurate and reliable measurements can be sent to the control system. If the transmitter is configured incorrectly, it could cause false readings resulting in poor control or decision making.
- Always take proper precautions and consult the reference manual when configuring transmitters.

### 8.11.2 Device Configuration

Device configuration sets up the transmitter's software parameters for the specific application and control system logic. There are many parameters within the device that can be configured, but some of the more critical elements are units of measure, range points, zero trim, damping, and low flow cutoff.

#### 8.11.2.1 Units of Measure

It is important to set up the correct units of measure for each given measurement point so that the data can be easily used and understood. It is also essential to align the units used at the transmitter with the units used at the control system.

#### 8.11.2.2 Range Points

Range points allow the limits of the transmitter measurement to be set (e.g., the 4-20 mA points). It is necessary to set the range points to cover the entire operating range of the process and match the range points of the control system input.

#### 8.11.2.3 Zero Trim

Zero trim is a single-point offset adjustment to the transmitter output. A zero trim should be performed after every installation once the transmitter is in its final mounting position. This will compensate for the effects of the mounting position.

#### 8.11.2.4 Damping

The damping setting changes the response time of the transmitter; higher values can smooth out variations in output readings caused by noise in the process measurement. Determine the appropriate damping setting based on the necessary response time and acceptable level of process noise.

### 8.11.2.5 Low Flow Cutoff

Sometimes it can be difficult to differentiate low flow measurements from the process noise. Low flow cutoff allows a low flow point to be set so that the transmitter will output “0” below a designated measurement threshold. Setting a low flow point ensures that the transmitter outputs a true “0” reading when there is no flow, which is critical for applications where a totalizer is used since this will help ensure that process noise is not leading to an accumulation of false positive flow.

### 8.11.3 Flow Configuration

The flow computer can be integral to the transmitter electronics, in a separate local device or as part of the control system. Flow can be calculated as the square root of the differential pressure multiplied by a constant,  $K$ . In single variable transmitters, this is typically how the flow equation is handled. The square root of the DP can be calculated in the transmitter via the scaled variable output or in the control system. It is important not to define the square-root function in both the transmitter and the control system, as this will cause a large measurement error.

For a more accurate flow measurement, multivariable transmitters can calculate fully compensated mass or energy flow and output those measurements directly from the device. To accurately calculate fully compensated mass flow, the fluid type, process conditions, primary element, and line size must be configured. Each of these components feeds into the calculation of flow and has a large impact on performance if configured incorrectly. For more information, see [Chapters 9](#) and [10](#).

## 8.12 Calibration

Every transmitter manufacturer has different manufacturing processes and calibration procedures. The accuracy and performance of pressure transmitters are the result of the manufacturing process and the factory calibration procedure.

Emerson’s Rosemount sensors are manufactured using a characterization and verification process to determine each sensor’s unique characteristics over a range of multiple static pressure and ambient temperature points. This data is used in a polynomial curve fit algorithm to create a set of coefficients. These coefficients are used by the internal transmitter software to linearize the output of the sensor over the transmitter’s entire pressure and temperature operating range. Due to the linearity achieved during the characterization and verification process, only an offset and slope trim are required during the factory calibration procedure.

A calibration process using an offset and slope adjustment can also be done in the field. An example of an offset trim is shown in [Figure 8.26](#). However, most applications only require a specific type of offset trim, which is called a zero trim, to correct for mounting position and line pressure effects. Note how the specific offset trim shifts the device output to zero at a zero-reference pressure.

A slope trim is an adjustment that changes the slope of the sensor characterization curve, as shown in [Figure 8.27](#). When a calibration is performed, an offset trim should be done first. Immediately after, a slope trim should be performed to provide a slope adjustment to the characterization curve based on the offset trim value.

Figure 8.26: The sensor characterization curve during an offset trim.

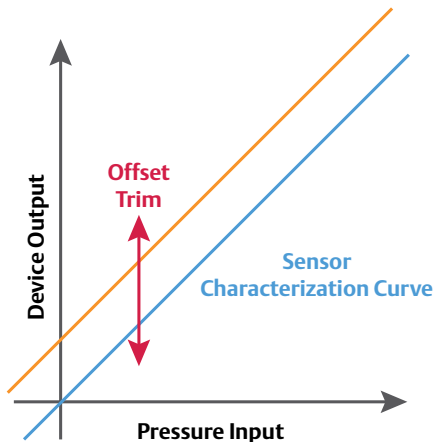
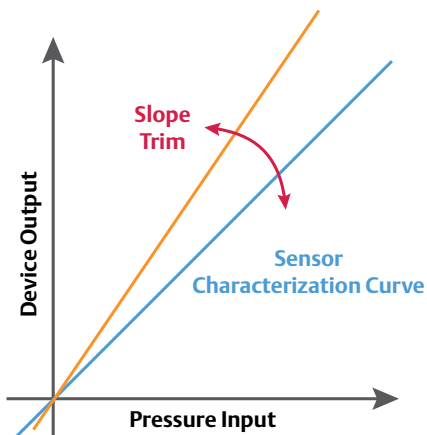


Figure 8.27: The sensor characterization curve during a slope trim.



The purpose of both trims is to align the device output with the sensor characterization curve. These procedures are performed on units during manufacturing. Emerson recommends that only an offset, or zero, trim be performed after installation. A full calibration comprising of both an offset and slope trim should only be completed if the transmitter is performing out of specification. For more information on calibration, see [Chapter 11](#).

## 8.13 Applicable Flow Meter Standards

There are some published standards for flow meters:

1. ISO 5167: Measurement of fluid flow by means of pressure differential devices inserted in a circular-cross section conduits running full
2. ASME MFC-3M: Measurement of Fluid Flow in Pipes Using Orifice, Nozzle, and Venturi
3. IEC 61511: Functional safety — Safety instrumented systems for the process industry sector
4. IEE 805.15.4: Standard for wireless protocols, which defines low power and low data rate networking

## 8.14 Additional Information

For more information, refer to the following source:

Miller, Richard W. *Flow Measurement Engineering Handbook*. 3rd ed., McGraw-Hill, 1996.





# 9

## Rosemount Primary Elements And Flow Meters

	<b>Topic</b>	<b>Page</b>
9.1	Introduction	174
9.2	Rosemount Integrated Flow Meter Portfolio	174
9.3	Rosemount Annubar Flow Meter	178
9.4	Conditioning Orifice Plate	187
9.5	Rosemount 1195 Integrated Orifice Primary Element	195
9.6	Traditional Orifice Plate Products	197
9.7	Rosemount Transmitters	198
9.8	Additional Information	208

### 9.1 Introduction

Emerson has been designing, fabricating, and selling components for differential pressure (DP) flow meters for over 50 years. With continuous improvement and innovation, today's DP flow meter products are the best in the industry. They continue to provide the highest performance in the most challenging industrial flow meter applications.

### 9.2 Rosemount Integrated Flow Meter Portfolio

The DP flow meter is made up of two discrete components: the DP flow primary element and the DP secondary device, or transmitter. Emerson offers a wide range of primary elements and transmitters to meet diverse applications and requirements. These components can be ordered and procured individually, or together to create one integrated flow meter solution. As shown in [Table 9.1](#), there are five different primary elements that can be assembled with four different transmitter styles, resulting in the industry's most comprehensive DP flow meter portfolio. It is important to note that this list does not encompass Emerson's complete Rosemount™ transmitter or primary element portfolio; rather, it shows the most common products that can be combined into a Rosemount integrated flow meter.

#### 9.2.1 DP Flow Meter System

Compared to other types of flow meter systems, the DP flow meter is unique in that its two components can be manufactured independently since differential pressure is a defined, measured, and traceable quantity. The primary element can be calibrated in a flow laboratory with a standardized meter and an output in differential pressure. The transmitter is calibrated to a defined differential pressure range using a precision calibration instrument. After assembly, the resulting flow meter is considered calibrated. This allows simultaneous fabrication and calibration of the DP flow primary element and secondary transmitter.

#### 9.2.2 Rosemount Integrated Flow Meter Versatility

Emerson's Rosemount DP flow product line provides the flexibility to meet measurement needs for a variety of applications in many industries. Process conditions and fluid type are the main drivers when specifying a flow meter. [Table 9.2](#) shows a simplified representation of the available primary elements and transmitter selections based on fluid characteristics. Applications for fluid metering can be very specific and may require a custom solution. A custom solution for a fully integrated and properly configured flow meter is available due to the breadth of the Rosemount DP flow meter offering.

## 9 – Rosemount Primary Elements and Flow Meters

Table 9.1: The most common combinations of Rosemount integrated flow meters. Note: not all combinations are shown.






























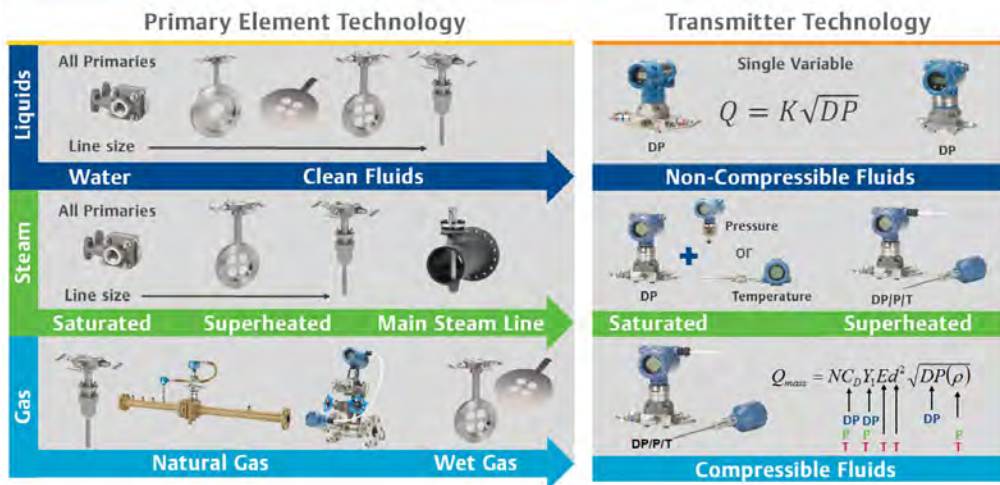
Primary element + Transmitter = Flow Meter  485 + 3051S = 3051SFA		Step 2: Pick transmitter based on desired performance.			
		 2051C	 3051C	 3051S	 3051SMV
Step 1: Pick primary element based on process requirements.	 485	 2051CFA	 3051CFA	 3051SFA	 3051SFA
	 405A	 2051CFC_A	 3051CFC_A	 3051SFC_A	 3051SFC_A
	 405C	 2051CFC_C	 3051CFC_C	 3051SFC_C	 3051SFC_C
	 405P	 2051CFC_P	 3051CFC_P	 3051SFC_P	 3051SFC_P
	 1195	 2051CFP	 3051CFP	 3051SFP	 3051SFP

Table 9.2: Rosemount DP flow meter systems by fluid type and application.

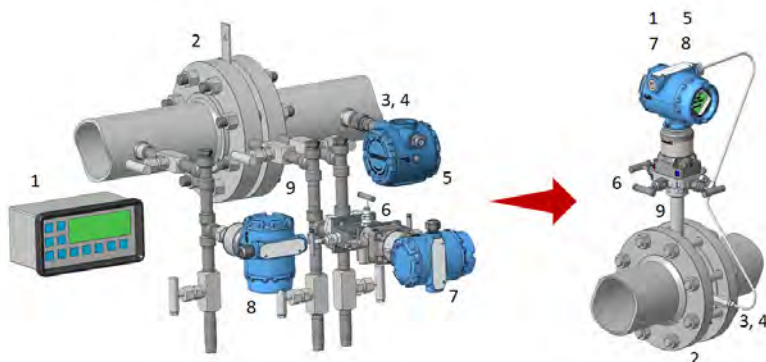


### 9.2.3 Benefits of the Rosemount Integrated Flow Meter

Emerson’s Rosemount integrated flow meter offering has the flexibility to be used in a wide variety of applications due to the different transmitter and primary element combinations available. Traditionally, a DP flow installation has required several different components, often sourced from multiple vendors, with each part

requiring its own installation and operation procedure. However, all of the Rosemount integrated flow meters combine these components into one model number sourced from a single vendor, drastically reducing overall complexity and engineering time. *Figure 9.1* shows a comparison between a traditional installation and the Rosemount integrated flow meter.

Figure 9.1: A comparison between a traditional DP flow installation and a Rosemount integrated flow meter.



- |                            |                         |
|----------------------------|-------------------------|
| 1. Flow Computer           | 6. DP Manifold          |
| 2. Primary Element         | 7. DP Transmitter       |
| 3. Thermowell              | 8. Pressure Transmitter |
| 4. Temperature Sensor      | 9. Connection Hardware  |
| 5. Temperature Transmitter |                         |



There are many additional benefits of Rosemount integrated flow meters:

- Every Rosemount integrated flow meter comes fully calibrated, leak checked, and configured for the specific application.
- There are fewer leak points compared to traditional DP flow installations.
- There are reduced installation and maintenance costs due to having fewer individual components, such as not having impulse lines.
- Multivariable flow meters reduce the number of pipe penetrations by integrating static pressure and temperature measurement into one assembly.
- Remote mounting the transmitter head can distance the electronics from harsh environments and make local viewing and maintenance more accessible.

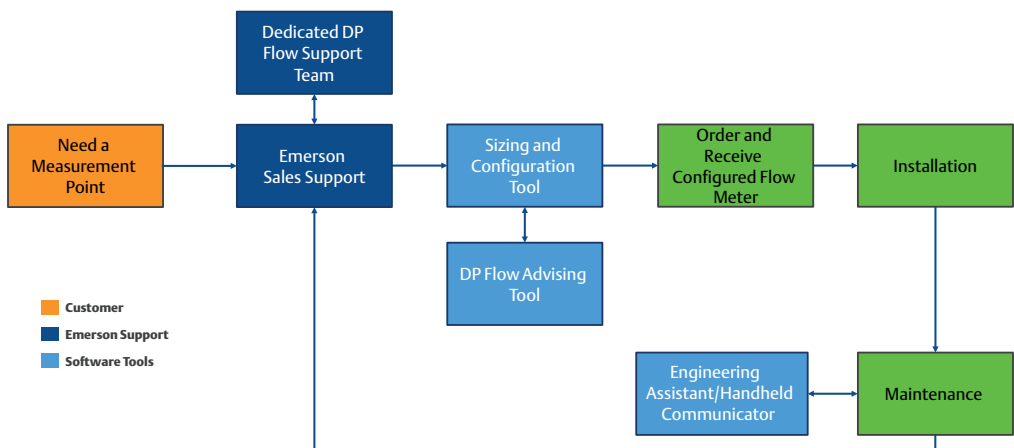
### 9.2.4 Flow Meter Sizing and Configuration

Sizing is the process of selecting the most appropriate primary element and transmitter for the application. Since flow meters are application-specific, they need to be sized properly to ensure safe and accurate operation. Fluid properties, pipe information, and special process characteristics are the most common pieces of information needed for proper sizing. Emerson offers software tools and resources to assist in the sizing of a DP flow meter in the following ways:

- Review compatibility of primary element and process information
- Perform necessary calculations including:
  - Total system performance
  - Permanent pressure loss
  - Differential pressure at given flow rates
  - Flow rate limits for safe operation
- Compare different flow meter technologies
- Determine energy costs and installed costs based on user-defined parameters
- Build a valid model number step-by-step

*Figure 9.2* is a visual representation of the DP flow sizing and ordering process.

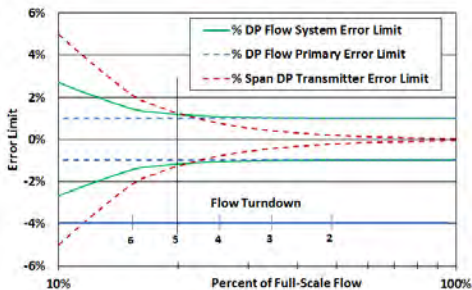
**Figure 9.2: The process for sizing and configuring Rosemount DP flow meters.**



### 9.2.5 DP Flow Meter System Performance

The DP flow meter is made up of two distinct elements: the DP flow primary device and the secondary DP or flow transmitter. The final system performance requires combining the performance of these two elements. This must be done using the standard uncertainty performance specifications for the two components. Most DP primary devices are considered to have a percent of reading performance, which means that the performance stays constant over the operating range. However, typical DP or flow transmitters are percent of span performance devices, which means that the possible error in reading increases as the flow rate decreases. Emerson's Rosemount DP and flow transmitter products are available with a percent of reading performance, which greatly enhances the DP flow meter performance. *Figure 9.3* shows the separate and combined performance of a typical DP flow meter. Note that in a simplified analysis for a 5:1 flow turndown, the system error limit is nearly the same as the meter primary element error limit, but for higher turndowns, the DP transmitter adds more error to the system. A more complete analysis would account for changes in unmeasured variables such as fluid density.

**Figure 9.3:** DP flow meter system error for a 0.05% of span DP transmitter and 1% of reading flow meter primary element.

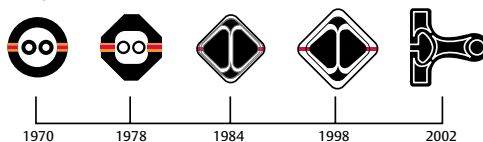


### 9.3 Rosemount Annubar Flow Meter

The Rosemount 485 Annubar™ Primary Element, which was introduced to the market in 2002, has innovative features that provided higher differential pressures and a new cylinder shape to enhance performance and integrate more easily with the Rosemount DP transmitter and flow meters. *Figure 9.4* shows the evolution of the Annubar Primary Element design. The Rosemount 485 design builds on the legacy of several generations of the Annubar Primary Element concept going back to 1966. Years of experience with averaging pitot tube applications contributed to the development of the Rosemount 485 Annubar Primary Element.

The Rosemount 585 diamond-shaped, severe-service Annubar Primary Element was continued from earlier designs with enhancements to provide application-specific models for main steam line, high temperature, and corrosive flows.

**Figure 9.4:** The evolution of the Annubar Primary Element design.



#### 9.3.1 Advantages of the Annubar Primary Element

The Annubar primary element provides the latest in averaging pitot tube technology with two of the best performing sensor designs built into the most versatile and popular installation platforms. With Emerson's family of Rosemount DP transmitters and flow meters, the Annubar DP flow meter:

1. Can be easily installed in most any piping branch with minimal welding and permanent pressure loss.
2. Is available using a simple packing gland, flanged, or wafer mounting.


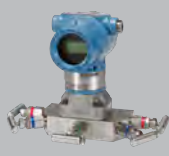

















3. Can be hot tapped and/or removed while the piping is under pressure using the Flo-Tap model.
4. Is available in a wide variety of metal alloys for high temperature and/or corrosive fluid applications.
5. Provides the best selection of customizable solutions for difficult or unusual flow meter applications.

with several of the available Rosemount DP and flow transmitters. Not all Annubar flow meters can be factory-assembled as an integrated flow meter, but they can all be ordered with the same transmitter models and integrated on-site. [Table 9.3](#) shows the Rosemount Annubar flow meter product offering with the available associated flow meter models or the transmitters. Rosemount flow meter configuration software provides all the available component options and checks the compatibility between the different components.

### 9.3.2 Annubar Flow Meters

As shown earlier in [Table 9.1](#), the Annubar flow meter is available as an integrated flow meter

**Table 9.3: The most common Rosemount Annubar flow meter systems. Note: not all Annubar flow meter installation combinations are shown.**

Primary Element + Transmitter = Flow Meter		Step 2: Pick transmitter based on desired performance.			
485 + 2051C = 2051CFA		 2051C	 3051C	 3051S	 3051SMV
Step 1: Pick primary element based on requirements.	 485	 2051CFA	 3051CFA	 3051SFA	 3051SFA
	 585	 585 + 2051C	 585 + 3051C	 585 + 3051S	 585 + 3051SMV
	 405A	 2051CFC_A	 3051CFC_A	 3051SFC_A	 3051SFC_A

### 9.3.3 Annubar Primary Element: Performance by Design

Averaging pitot tube technology was discussed in [Chapter 7](#). The primary performance parameters for an averaging pitot tube are:

1. Proper averaging of the impact or fluid stagnation pressure
2. A low or reference pressure that is a consistent percentage of the stagnation pressure over the industrial flow meter operating range

The first parameter is achieved by the design and location of the sampling ports system on the front surface of the averaging pitot tube. The second parameter is achieved by the design of the cylinder shape and location of the low-pressure sensing ports on the cylinder of the averaging pitot tube. The effects of a proper design will provide the following performance characteristics:

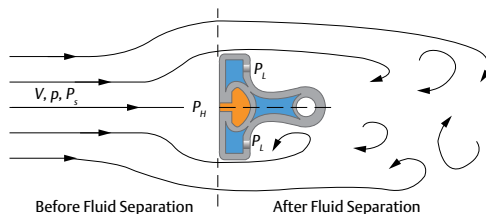
1. A linear flow coefficient for a given application over the range of flow rate measured. While this seems to be a given quality, it is only possible if the averaging pitot tube has the proper design.
2. A predictable flow coefficient given the geometry of the sensor and pipe size it is installed in. This is only possible if the design has been characterized over the range of pipe sizes for each averaging pitot tube model and a sufficient number of calibrations have been done. Also, using this information only makes sense if the manufacturing process produces a consistent, quality product.

### 9.3.4 Rosemount 485 Annubar Primary Element

The Rosemount 485 Annubar Primary Element uses the T-shaped cylinder as the differential pressure sensor. As with most of the prior Annubar primary element designs, the T-shape is a drag port averaging pitot tube, which means that the low pressure is measured on the downstream-facing side of the cylinder after the fluid has separated. While this location is

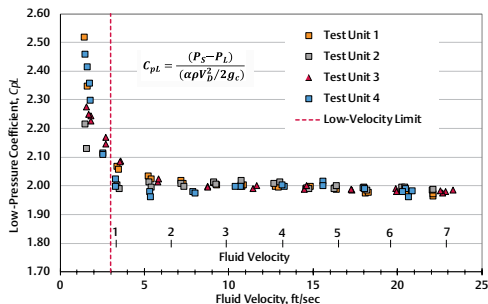
in a turbulent area, the effects of separation create a consistent and repeatable low-pressure measurement zone over a wide range of fluid velocities. This is necessary to achieve the two performance requirements listed in [Section 9.3.3](#). To help reduce the noise created by the vortex shedding, two sets of low-pressure ports are used that are on opposite sides of the Rosemount 485 cylinder. [Figure 9.5](#) shows the T-shaped cylinder in a flow stream. The high-pressure chamber is shown in the orange cross-section and the low-pressure chamber in blue.

**Figure 9.5: The T-shaped averaging pitot tube cylinder and pressure chambers.**



The performance of this cylinder shape is best demonstrated by showing the value of the low-pressure coefficient at a wide Reynolds number range. [Figure 9.6](#) shows the low-pressure coefficient reading for the Rosemount 485 Annubar Primary Element in water service. The results for four different test units are quite linear for velocities from 23 down to 3 ft/sec (7 down to 0.9 m/sec). The lowest velocity is determined at the point where the fluid separation dynamic changes, and there is a change in the value of the coefficient. This limit is used in the configuration programs. For a water flow, this is 2 to 3 ft/sec (0.6 to 0.9 m/sec) below most liquid operating flow ranges.

Figure 9.6: T-shaped averaging pitot tube low-pressure coefficient,  $C_{pL}$ , for water flow.



The high-pressure measurement for an averaging pitot tube does not rely on the cylinder shape; it only matters that the fluid comes to rest, or stagnates, at the front surface. For this reason, most averaging pitot tube designs will give comparable results for measuring the average stagnation pressure. The Rosemount 485 Annubar Primary Element uses one or more slots to sense and measure the fluid dynamic pressure. This is different from the traditional averaging pitot tube, which uses individual holes or ports to sample the velocity. Slots are less likely to become completely obscured due to particulates and span the complete pipe diameter, which can provide a better average pressure in asymmetric velocity fields. Figure 9.7 shows the Rosemount 485 in a pipe as well as the method of averaging the velocities.

Figure 9.7: Rosemount 485 Annubar Primary Element velocity sampling.

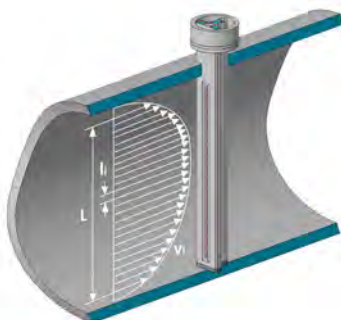
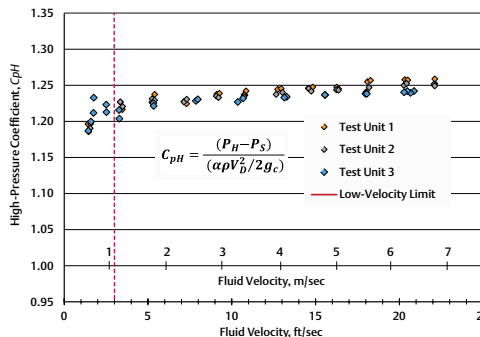


Figure 9.8 shows the high-pressure coefficient for the same Rosemount 485 Annubar primary element test units over the same range of water flows. Perfect fluid stagnation would give a coefficient of 1.000. The value of an averaging pitot tube high-pressure coefficient is greater than 1.000 due to the blockage effect of the cylinder in an enclosed pipe. As the pipe size increases for the same size sensor size, this effect goes down. See Chapter 7 for derivations of the averaging pitot tube pressure coefficients.

Figure 9.8: T-shaped averaging pitot tube high-pressure coefficient,  $C_{pH}$ , for water flow.

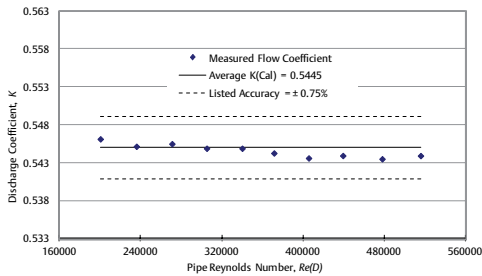


The performance of the flow coefficient for the Rosemount 485 Annubar primary element depends on the high- and low-pressure coefficients. The value of the flow coefficient,  $K$ , is given by:

$$K = \frac{F_{PD}}{\sqrt{C_{pH} + |C_{pL}|}}$$

An example of a flow calibration is shown in Figure 9.9. The advantage of a differential pressure flow meter is that the primary element can be calibrated independent of the secondary meter or transmitter. This allows pairing the primary element to any of the many possible DP or flow meter systems available. A calibration determines the value of the flow coefficient over the range of calibration. For an area meter, it is the discharge coefficient. To make the results universal for any type of fluid, the Reynolds number is used.

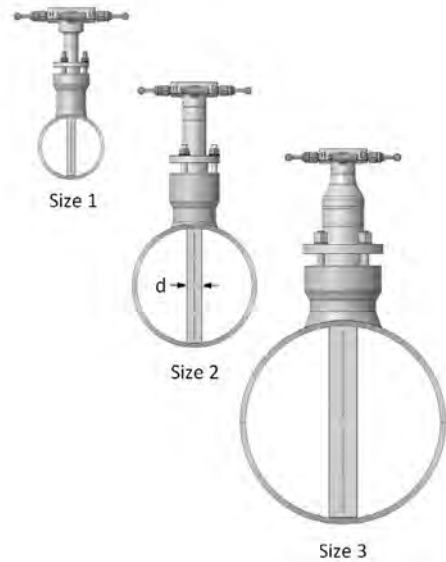
**Figure 9.9: Flow coefficient vs. pipe Reynolds number for a Rosemount 485 Annubar Primary Element, size 1, 4-in. (100 mm) pipe size.**



For a Rosemount 485 Annubar Primary Element, the value of a flow coefficient of 0.5445 gives a measured differential pressure of over 70 inH<sub>2</sub>O (17.4 kPa) at a 10 ft/sec (3.3 m/sec) water velocity. Compare this with a leading averaging pitot tube manufacturer where the flow coefficient is 0.72, and the DP for the same application would be 40 inH<sub>2</sub>O (9.9 kPa). High DPs are easier to measure, can be turned down (to lower flow rates), and provide a better performance from a DP transmitter.

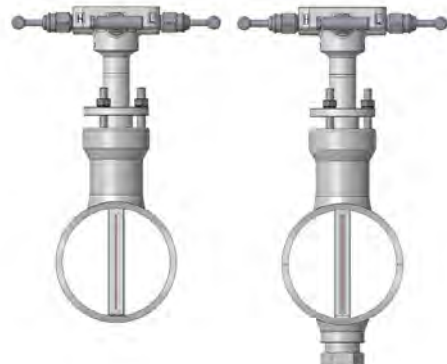
The cylinder, or sensor, sizes for the Rosemount 485 Annubar primary element span the range of pipe sizes from 2 to 96 in. (50 to 2400 mm). Other sizes can be ordered as an engineered-to-order solution (i.e., a special). *Figure 9.10* shows the three sizes of the T-shaped sensor and the typical range of pipe sizes that they are suitable for. The need for larger size sensors is due to the mechanical strength required when mounting in larger pipes. When an Annubar sensor is sized for an application, the results ensure that the selected sensor size passes the structural requirements. In addition to sensor size, the support of the sensor in the mounting hardware can also improve the strength of the sensor. If a sensor is supported at both ends, structural strength is increased without using a larger sensor. *Figure 9.11* shows single- and double-supported mounting for the size 1 sensor. The Rosemount 485 Annubar sensor is available in 316 stainless steel and Alloy C-276.

**Figure 9.10: Three sensor sizes for the Rosemount 485 Annubar Primary Element.**



Sensor Size	Sensor Width, d-in. (mm)	Pipe Size Range, in. (mm)	Mount Hardware Size, in. (mm)
1	0.59 (15)	2-8 (50-200)	1-1/2 (38)
2	1.06 (27)	6-96 (150-2400)	2 (50)
3	1.93 (49)	≥ 12 (300)	3 (80)

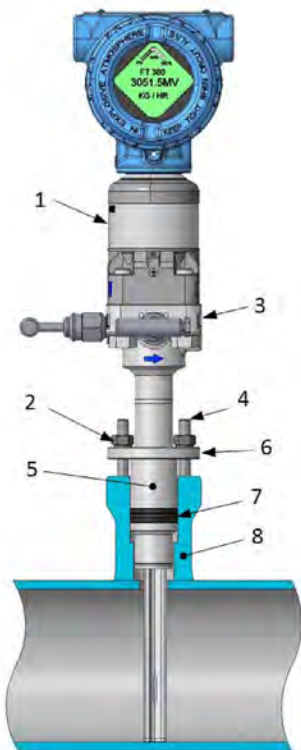
**Figure 9.11: Rosemount 485 Annubar single- and double-supported sensors.**



The Rosemount 485 Annubar primary element mounting style is determined by the type of installation that is required. The available mounting options are:

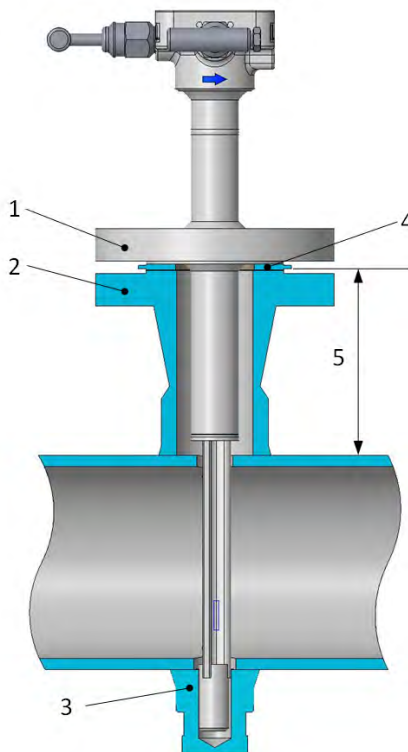
1. Pak-Lok — A simple, soft-packing mounting that can be used for most applications. See [Figure 9.12](#). As the packing gland is tightened, the sensor is pressed against the pipe wall, and the seal is compressed to ensure a leak-tight, supported sensor.

**Figure 9.12: Rosemount 485 Pak-Lok mounting shown with a Rosemount 3051S MultiVariable transmitter.**



- |                   |                      |
|-------------------|----------------------|
| 1. DP Transmitter | 5. Packing Follower  |
| 2. Packing Nut    | 6. Packing Cover     |
| 3. Integral Head  | 7. Packing Rings (3) |
| 4. Packing Stud   | 8. Pak-Lok Body      |

**Figure 9.13: Rosemount 485 with flanged mounting style.**

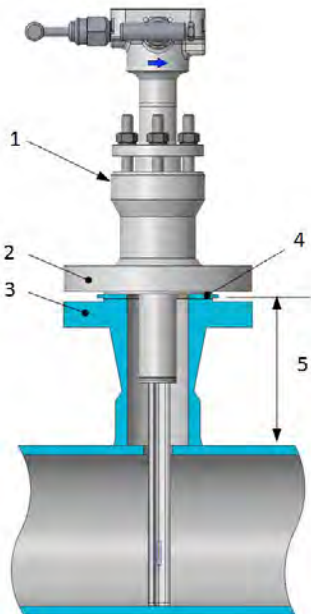


- |                     |
|---------------------|
| 1. Sensor Flange    |
| 2. Mounting Flange  |
| 3. Support Coupling |
| 4. Gasket           |
| 5. ODF Dimension    |

2. Flanged — A fully welded Annubar Primary Element mounting using a customer-specified flange type (e.g., DIN or JIS). See [Figure 9.13](#). A mounting flange hub and hardware for double-supporting the sensor is provided. Double support is needed, as a single support system would require a clearance gap between the pipe inside wall and the sensor tip. This changes the low pressure due to flow under the sensor tip. If the flange mounting is customer-supplied, it is important to determine the height of the flange face above the pipe wall, or ODF (pipe OD to flange face), before the Annubar Primary Element is ordered.

3. Flange-Lok — A combination of the previous mounting styles when a flange mounting connection is desired, but a soft packing is allowed. [Figure 9.14](#) shows how this mounting eliminates the need for an exact ODF value and can be provided as a single-support system.

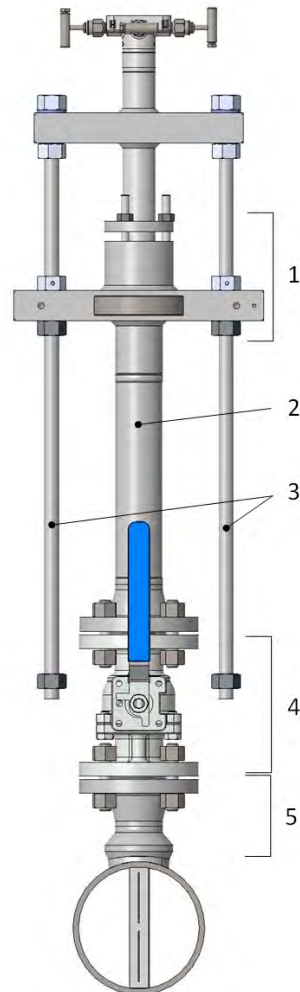
**Figure 9.14: Rosemount 485 Flanged Pak-Lok mounting style.**



1. Sensor Flange
2. Pak-Lok Flange
3. Mounting Flange
4. Gasket
5. ODF Dimension

4. Flo-Tap — A system that allows insertion or retraction of the sensor under pressure. Flo-Tap systems include a packing gland and an isolation valve, and a mechanism to move the sensor. [Figure 9.15](#) shows a flanged Flo-Tap where the mounting hardware and valve are flanged. Threaded versions and gear-drive options are also available. See [Chapter 10](#) for more information about hot tapping an averaging pitot tube.

**Figure 9.15: Rosemount 485 Flo-Tap mounting style.**



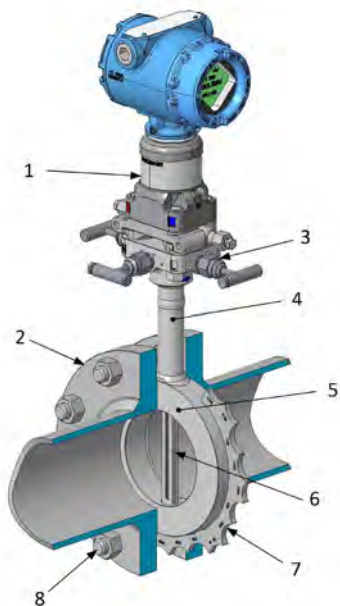
1. Packing Gland
2. Cage Nipple
3. Drive Rods
4. Isolation Valve
5. Mounting Flange



### 9.3.5 Rosemount 405A Annubar Primary Element

The Rosemount 405A Annubar Primary Element is a member of the Rosemount 405 family of products with an Annubar sensor as the measuring element. The basis of the Rosemount 405 platform is the use of a thick disk, or wafer, that is designed to fit between standard ANSI or other common flanges. The instrument connections are provided in the transmitter-mountable integral head that is welded to the top of a post or neck, which extends beyond the flanges for access. *Figure 9.16* shows the Rosemount 405A Compact Annubar Primary Element, which utilizes the Rosemount 485 sensor size 1 averaging pitot tube primary element with a direct-mount style head installed as a double-supported sensor in the wafer.

**Figure 9.16: Rosemount 405A Compact Annubar Primary Element.**



- |                           |                            |
|---------------------------|----------------------------|
| 1. DP or Flow Transmitter | 5. Meter Wafer             |
| 2. Pipe Flange            | 6. Annubar Primary Element |
| 3. Direct-Mount Head      | 7. Alignment Ring          |
| 4. Meter Neck             | 8. Flange Stud             |

The Rosemount 405 platform is offered for two other primary elements: the Rosemount 405C Compact Conditioning Orifice Plate and the Rosemount 405P Compact Orifice Plate. The compact series of meters allows for the direct mounting of a Rosemount DP or flow transmitter to the primary element. This greatly simplifies flow meter integration and installation. The Rosemount 405A is provided for pipe sizes from 2 to 8 in. (50 to 200 mm).

Each Rosemount 405 meter is supplied with an alignment ring that is made from 0.25-in. (6 mm) thick aluminum. It fits between the outside of the wafer and the flange studs. Alignment rings center the meter wafer in the pipe during installation and are made for each nominal pipe size. Each ring includes labeled features for three or more flange pressure ratings. *Figure 9.17* shows the alignment ring positioned on the flange studs to center the Rosemount 405 meter wafer. The locations of the features for ANSI Class 150, 300, and 600 flanges are stenciled on the alignment ring. Similar alignment rings are available for DIN and JIS flanges.

**Figure 9.17: Rosemount 405 platform alignment ring.**

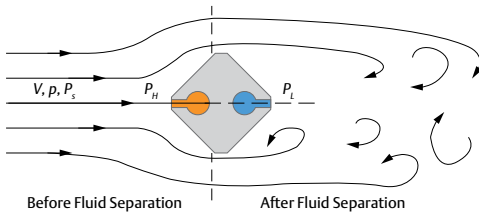


### 9.3.6 Rosemount 585 Annubar Primary Element

Some designs of the Annubar Primary Element use a diamond-shaped cylinder. A version of this type of Annubar Primary Element is made from a single piece of metal alloy by gun-drilling the two pressure chambers. The advantage of this type of construction is the absence of welds in the exposed and loaded portion of the averaging pitot tube. This allows applications for high load, high temperature, and potentially corrosive environments where welds can create stress-related corrosion.

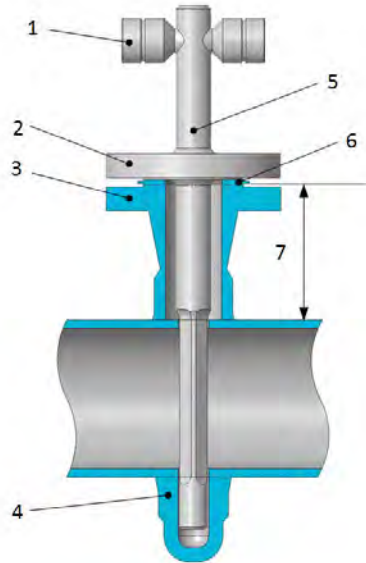
*Figure 9.18* shows the Rosemount 585 cylinder in a flow stream with the high-pressure chamber shown in the orange cross section and the low pressure in blue. The diamond shape provides a stable low-pressure coefficient. The Rosemount 585 cylinder uses sampling holes or ports instead of slots. These holes are positioned so that they are oriented around the pipe center using the Chebyshev sampling method. The Rosemount 585 is available in Flanged and Flo-Tap styles only. Since this sensor design is symmetrical, it can measure flow in both directions and is used for applications that require bi-directional flow.

**Figure 9.18: Rosemount 585 diamond-shaped Annubar Primary Element and pressure chambers.**



*Figure 9.19* shows the Rosemount 585 Flanged model. The single solid sensor construction allows fabrication from any metal alloy that can be provided in a machinable bar stock.

**Figure 9.19: Rosemount 585 Annubar Primary Element flanged mounting style.**



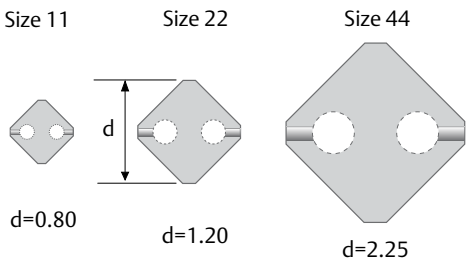
- |                      |                       |
|----------------------|-----------------------|
| 1. Pressure Taps     | 5. Gun-Drilled Sensor |
| 2. Sensor Flange     | 6. Gasket             |
| 3. Direct-Mount Head | 7. ODF Dimension      |
| 4. Support Coupling  |                       |

Many different metal alloys have been used to fabricate special Rosemount 585 Annubar Primary Elements for high temperature and corrosive fluid flow applications. Some of the alloys that have been used for the Rosemount 585 are:

1. Austenitic stainless steels — 304, 304L, 316, 316L, 310, and 321
2. Duplex stainless steel — 2205 (UNS S31803)
3. Nickel alloys — Alloy C-276, Alloy 330, Alloy 400, and Alloy 800H
4. Titanium — Grades 2 and 3

The Rosemount 585 also comes in the three sensor sizes shown in *Figure 9.20*.

Figure 9.20: The Rosemount 585 Annubar sensor sizes.



### 9.3.7 Performance

The performance for an Annubar Primary Element is determined at reference conditions using a proper installation and for a pipe that has been measured for the correct inside diameter (ID). The actual installed performance will be affected by flow turbulence and the uncertainty of the measuring instruments, including the uncertainty of the true pipe ID if it is not measured. Maximum flow rates for Annubar Primary Elements are limited by the structural strength of the size and type of sensor. See [Chapter 7](#). The minimum flow rate is limited by the minimum rod Reynolds number. See [Chapter 3](#). [Table 9.4](#) shows the reference uncertainty for the different Annubar Primary Element models.

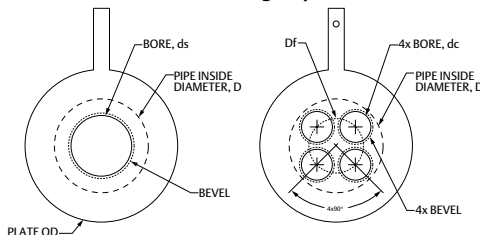
Table 9.4: Rosemount Annubar Primary Element uncertainty by model number.

Model	Sensor Size	Flow Coefficient Uncertainty	Minimum Rod Reynolds Number
485	1	±0.75%	6500
	2	±0.75%	12500
	3	±0.75%	25000
585	11	±1.50%	6500
	22	±1.50%	10000
	44	±1.50%	25000
405A	1	±1.00%	6500

## 9.4 Conditioning Orifice Plate

Emerson developed the Rosemount Conditioning Orifice Plate technology, which specifically refers to the 4-bore orifice design. [Figure 9.21](#) shows the geometry of the traditional and Conditioning Orifice Plate.

Figure 9.21: Dimensions for traditional single-bore and Rosemount 4-bore Conditioning Orifice Plates.



Note that for a single-bore plate, the calculation of the beta is:

$$\beta = \frac{d_s}{D}, \text{ and, } \beta^2 = \left(\frac{d_s}{D}\right)^2 = \frac{a_s}{A_{Pipe}}$$

And for the 4-bore Conditioning Orifice Plate is:

$$\beta^2 = \frac{4a_c}{A_{Pipe}} = 4\left(\frac{d_c}{D}\right)^2, \text{ or, } \beta = \frac{2d_c}{D}$$

Where:

- $\beta$  Orifice beta used in the calculation
- $d_s$  Diameter of the single-bore orifice plate
- $D$  Pipe diameter
- $a_s$  Area of the single-bore orifice
- $A_{Pipe}$  Area of the pipe
- $a_c$  Area of one of the four bores for the Conditioning Orifice Plate
- $d_c$  Diameter of the Conditioning Orifice Plate bore

From this result, the equivalent single-bore diameter for a 4-bore Conditioning Orifice Plate is:

$$d_s(\text{Equivalent}) = 2 \times d_c$$

### 9.4.1 Advantages of the Rosemount Conditioning Orifice Plate

The orifice plate has remained the most recognizable and used type of primary element. The sizing, configuration, and installation of the orifice plate has become well known and documented, and it is taught in engineering schools. The advent of the modern DP transmitter, led by Emerson, and the digital-based flow meter has breathed new life into the DP flow meter and greatly enhanced the accuracy and utility of the sharp-edged orifice plate. However, it is the Conditioning Orifice Plate suite of products that has taken this technology to the next level and now provides a flow meter that has several significant advantages:

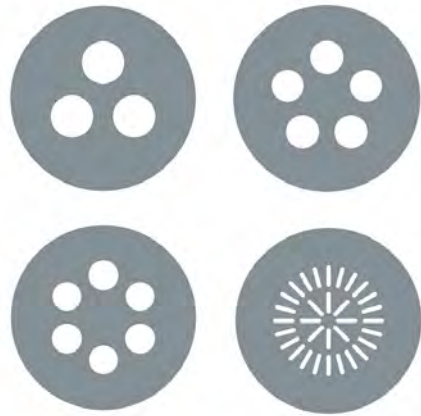
1. Can be installed with only two pipe diameters of straight pipe upstream and downstream between many types of fittings and provide calibrated uncertainties of 0.50 to 1.50%
2. Can be ordered as a complete, self-contained, and configured flow meter for most applications for liquid, gas, or steam flow
3. Covers pipe sizes from 2 to 24 in. (50 to 600 mm). Larger pipe sizes can be ordered as an engineered-to-order solution (i.e., a special)
4. Is available in most pipe sizes uncalibrated with only a modest increase in uncertainty

The acceptance of the orifice plate as the go-to primary element and the superior performance and utility of the Rosemount Conditioning Orifice Plate makes it the ideal flow meter for almost any industrial flow measurement application.

### 9.4.2 Rosemount Conditioning Orifice Plate vs. the Multi-Hole Orifice Plate

There are other similar orifice plate designs, which are generically called multi-hole orifice plates. See [Figure 9.22](#).

*Figure 9.22: Several bore arrangements of multi-hole orifice plates.*

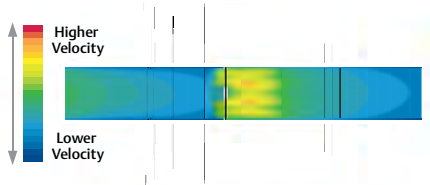


They all do a good job of providing predictable results after many types of pipe flow disturbances. However, the 4-bore system is superior due to the following facts:

1. Fewer bores (2 or 3) are not symmetrical over the plate area in all planes, so the orientation of the plate to upstream fittings becomes more of an issue.
2. More bores (5, 6, and up) force the bore centers toward the pipe wall, and higher beta values (i.e., larger bores) are limited due to the area available unless a center bore is used.
3. A bore in the center will cause more turbulence to enter the downstream field, which may reduce the conditioning effect.
4. Many very small or odd-shaped holes for a conditioning orifice are difficult to measure precisely if the meter is uncalibrated, so each plate requires calibration if an accurate flow meter is required.
5. The 4-bore Conditioning Orifice Plate uses the same circular bore and edge design as the traditional orifice plate. This makes reproducing and measuring the bores possible and allows offering uncalibrated plates at a reasonable cost and delivery.

As stated in [Chapter 7](#), the science behind the multi-hole orifice plate is in the conservation of energy in moving the fluid through multiple bores. The least energy lost is when the flow through each bore is balanced. [Figure 9.23](#) shows the quick recovery of pressure as flow travels through a multi-hole orifice plate. This arrangement is nearly unaffected by the upstream velocity field. It is important to note, however, that the conditioning effect begins to wane as the value of beta ( $B$ ) increases.

**Figure 9.23: Energy conservation for a multi-hole orifice plate.**



The 4-bore Conditioning Orifice Plate is constructed in a similar fashion to the traditional single-bore orifice plate. The requirements for surface finish, flatness, bore tolerance, and edge sharpness are the same for the Conditioning Orifice Plate as they are for the traditional plate. There are three basic Conditioning Orifice Plate models:

1. Rosemount 1595 — A paddle-type plate (also available as a universal plate) that uses flange taps
2. Rosemount 405C — Installed in the Rosemount compact platform and uses corner taps
3. Rosemount 9295 Process Meter — Incorporated into a spool as a single machined piece with no welds in the flow stream. It is ideal for difficult and critical applications

All of these models can be installed with little or no straight pipe requirements. For the Rosemount 405C and 1595 products, a minimum of two pipe diameters downstream and two pipe diameters upstream from many types of pipe fittings are needed. For the Rosemount 9295, no additional straight pipe is required. See [Chapter 10](#)

for a table of straight pipe requirements for the Rosemount Conditioning Orifice Plate models.

### 9.4.3 Conditioning Orifice Plate Flow Meter Products
















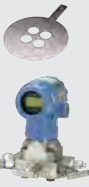



[Table 9.5](#) shows the types of flow meters that are available for the Conditioning Orifice Plate products. The Rosemount 405C can be integrated fully with the DP or flow transmitter. The Rosemount 1595 must be integrated at the installation site, and the Rosemount 9295 can be supplied as an integrated meter that is pressure tested, flow calibrated, and fully configured for the application.

### 9.4.4 Rosemount 405C Compact Conditioning Orifice Plate Flow Meter

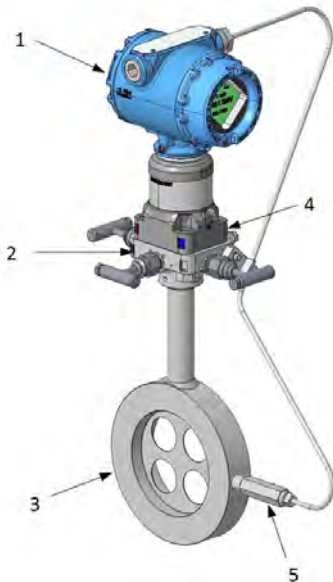
The Conditioning Orifice Plate can be installed in existing piping systems without the need for long lengths of straight piping, or meter runs. This capability is greatly enhanced by offering the product in the Rosemount 405 platform, which provides a system that can be installed between existing, standard pipe flanges. Thus, the Rosemount 405C product was born: an integral DP flow meter for 2-, 3-, 4-, 6-, 8-, 10-, and 12-in. (50, 80, 100, 150, 200, and 250 mm) pipe sizes that is fully configured and does not require special flow meter mounting, additional valves, impulse piping, or instrumentation for temperature or pressure measurement. [Figure 9.24](#) shows the fully configured Rosemount 405C as a pressure and temperature-compensated flow meter designated as Rosemount 3051SFC\_C.

## 9 – Rosemount Primary Elements and Flow Meters

Table 9.5: Flow meters available for the Rosemount Conditioning Orifice Plate products.

Primary Element + Transmitter = Conditioning Orifice Plate  405C + 3051C = 3051CFC_C		Step 2: Pick transmitter based on desired performance.			
		 2051C	 3051C	 3051S	 3051SMV
Step 1: Pick primary element based on requirements.	 405C	 2051CFC_C	 3051CFC_C	 3051SFC_C	 3051SFC_C
	 9295	 9295 + 2051C	 9295 + 3051C	 9295 + 3051S	 9295 + 3051SMV
	 1595	 2051C + 1595	 3051C + 1595	 3051S + 1595	 3051SMV + 1595

**Figure 9.24: The Rosemount 405C Conditioning Orifice Plate flow meter.**



1. Rosemount 3051S Flow Transmitter
2. Integral Head with Valves
3. Rosemount 405 Wafer with Conditioning Orifice Plate
4. Bleed/Drain Valves
5. Integral RTD

The Rosemount 405C product can be paired with many different types and performance classes of Rosemount DP and flow transmitters. The Rosemount 405 wafer system, which includes the alignment ring mentioned in [Section 9.3.5](#) (see [Figure 9.25](#)), can be installed between:

- ANSI Class 150, 300, and 600 rating flanges
- DIN PN 16, PN40, and PN100 rating flanges
- JIS 10K, 20K, and 40K rating flanges

**Figure 9.25: Alignment ring for the Rosemount 405C.**



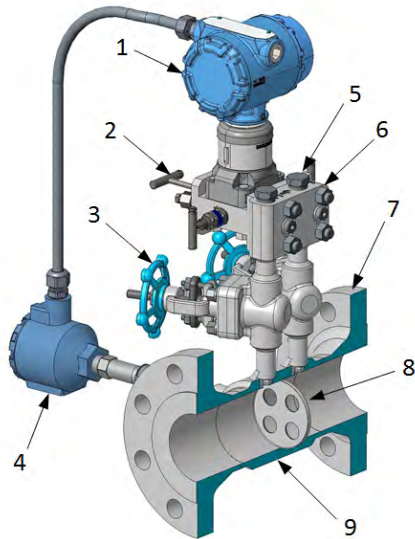
This latitude for configuration provides a flow meter for nearly every potential application for liquids, gases, and steam found in most industrial production and process plants. The Rosemount 405C is designed for schedule 40 class piping but can be configured for schedule 10 or schedule 80 classes (and other schedules by special order). The flow computer on-board the transmitter allows for on-site configuration of many types of fluids using a laptop computer, which allows stocking a minimum number of flow meter types.

### 9.4.5 Rosemount 9295 Process Flow Meter

Although the Rosemount 405C flow meter handles many types of fluid flow applications, it is not designed for the process refinery or plant where safety requirements preclude the use of wafer mounting. For this type of application, the Rosemount 9295 Process Meter was developed. At the heart of the Process Meter is a Conditioning Orifice Plate that is machined into a thick-walled, one-piece spool. There can be up to three sets of impulse piping welded to the spool, and there are weld-neck flanges on both ends. Custom bore sizes are offered so the meter can be sized for the application. Socket-welded gate valves are offered as primary isolation, or root, valves. The entire assembly can be hydro-tested to ensure system pressure integrity. [Figure 9.26](#) shows a cutaway of the Rosemount 9295, and [Figure 9.27](#) shows the redundant-tap version. Pipe sizes of 2-, 3-, 4-, and 6-in. (50, 80, 100, and 150

mm) are available with flange ratings for Class 150, 300, 600, and 900. Pipe schedules of 40, 80, 120, and 160 are available. Schedule 120 is only available in 4-in. (100 mm) and larger. In addition, full penetration weld construction and fully redundant instrumentation systems are provided as an option.

**Figure 9.26: Rosemount 9295 Process Meter.**



- |                       |                               |
|-----------------------|-------------------------------|
| 1. Flow Transmitter   | 6. Meter Head                 |
| 2. DP Manifold        | 7. Piping Flange              |
| 3. Welded Gate Valves | 8. Conditioning Orifice Plate |
| 4. RTD Housing        | 9. One-Piece Spool            |
| 5. Rod-Out Port Plug  |                               |

**Figure 9.27: Rosemount 9295 Process Meter with redundant flow transmitters and RTD.**



The Rosemount 9295 was extensively tested in the flow laboratory with many different types of piping fittings to meet the required performance specifications. Because the Rosemount 9295 is supplied in a spool, no straight run is required. This allows direct coupling of the meter to a single or multiple set of piping elbows in a variety of arrangements.

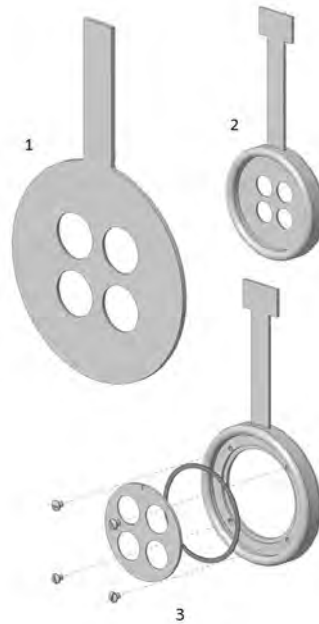


### 9.4.6 Rosemount 1595 Conditioning Orifice Plate

The simplest form of the orifice flow meter is the orifice plate, and the Rosemount 1595 is the conditioning version. The Rosemount 1595 is available for pipe sizes from 2 to 24 in. (50 to 600 mm) with standard beta values of 0.20, 0.40, 0.50 and 0.65 (0.60 for the 2-in. pipe size). Other beta values can be ordered as an engineered-to-order solution (i.e., a special). The benefits of short-run installations are more pronounced in large pipe sizes. For example, a 36-in. (900 mm) pipe size with a straight pipe requirement of 40 diameters would require 120 ft. (36 m) of straight pipe. For this reason, the Rosemount 1595 is available as a special order for pipe sizes greater than 24 in. and up to 48 in. (600 to 1200 mm).

To satisfy special installations, universal orifice plates are offered. A universal plate is typically a plate without a handle that is designed to be inserted in a holder. Most plate-holder configurations are made for ring-joint style flanges. Emerson provides a one-piece plate for the 2- and 3-in. (50 and 80 mm) pipe sizes, and for larger pipe sizes, a separate plate and plate holder. *Figure 9.28* shows the various types of Rosemount 1595 models. While the standard tap arrangement is flange taps, corner and radius ( $D$ ,  $D/2$ ) taps are supported. The standard material for the Rosemount 1595 is 316 stainless steel. Optional materials are Alloy 400 and Alloy C-276.

*Figure 9.28: Rosemount 1595 Conditioning Orifice Plate models for paddle and universal for ring-joint flanges.*



1. Rosemount 1595 Paddle-Style Plate
2. Rosemount 1595 Universal Style for 2- and 3-in. (50 and 80 mm) Ring-Joint, Flanged Pipe Sizes
3. Rosemount 1595 Universal Style for 4- to 24-in. (100 to 600 mm) Pipe Sizes with Holder and Gasket

### 9.4.7 Conditioning Orifice Plate Performance

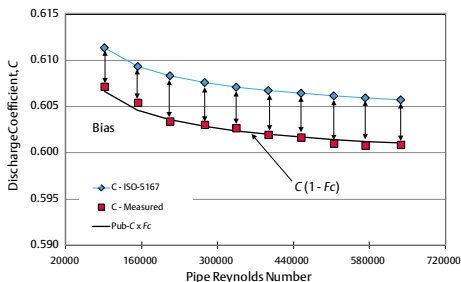
The multi-hole orifice plate concept could not have been pursued unless calibration results for these devices showed a comparable uncertainty to the traditional single-bore orifice, but in a short-run piping configuration. Early test results verified the effectiveness of the 4-bore Rosemount Conditioning Orifice Plate with the performance correlated to the value of beta ( $d/D$ ), and for some fittings, the orientation of the plane of the taps to the plane of the disturbance. See Chapter 10 for more information.

Like the Annubar, Primary Element, the performance of an orifice plate is primarily determined by the repeatability and predictability of the discharge coefficient. The

discharge coefficient,  $C$ , for the Conditioning Orifice Plate uses the same Reader-Harris Gallagher equation (see [Chapter 7](#)) as the traditional concentric sharp-edged plate with a slight modification. Although the change in  $C$  with Reynolds number is nearly identical, there is a shift in value called a bias for the 4-bore plate, which is due to the smaller orifice bores creating a low pressure that is closer to the plate surface. This shift is measured using a parameter called the calibration factor, or  $F_c$ .

[Figure 9.29](#) shows the relationship between the value of the Reader-Harris Gallagher orifice plate discharge coefficient, which is shown as  $C_d$ , and  $F_c$  for a Rosemount 405C, 8-in. (200 mm) pipe size for a 0.65 beta.

**Figure 9.29: Discharge coefficient and the calibration factor,  $F_c$ , for a Rosemount 405C, 8-in. (200 mm) pipe size for a 0.65 beta Conditioning Orifice Plate.**

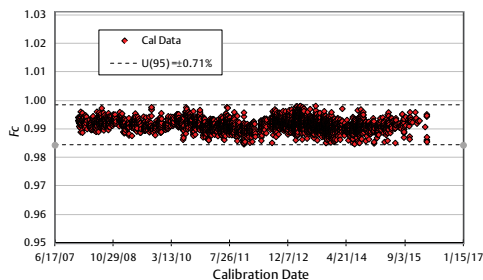


The Rosemount Conditioning Orifice Plate was tested in a variety of piping styles using different fittings upstream to test the effectiveness of the design. When it was released in 2002, a decision was made to calibrate every meter at reference conditions. This resulted in a large data sample for both products: Rosemount 1595 for pipe sizes from 2 to 24 in. (50 to 600 mm) and Rosemount 405C for pipe sizes from 2 to 12 in. (50 to 300 mm). In 2014, a program was initiated to offer an uncalibrated Conditioning Orifice Plate. This was possible because of the large data sample and the very repeatable calibration results. An analysis was done on the large data samples for three beta values: 0.40, 0.50, and 0.65, which provided a statistical average value and uncertainty for  $F_c$ .

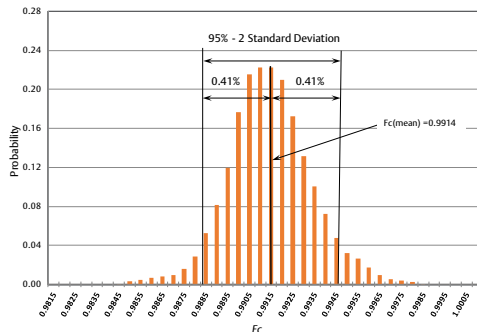
[Figure 9.30](#) shows an example of the data of the average  $F_c$  value by date, and [Figure 9.31](#) shows the statistical histogram of that data for a 4-in. (100 mm) pipe size Rosemount 405C with a 0.65 beta. There are two primary reasons for this convincing result:

1. It shows the quality control of the production process.
2. It shows consistent calibration practices for the flow laboratory and production product calibrations.

**Figure 9.30: Calibration data showing the calibration factor,  $F_c$ , for a Rosemount 405C, 4-in. (100 mm) pipe size, 0.65 beta plate from 2008 to 2014.**



**Figure 9.31: Probability histogram of the  $F_c$  data for a Rosemount 405C, 4-in. (100 mm) for a 0.65 beta.**



The listed uncertainty of the Rosemount Conditioning Orifice Plate is shown in [Table 9.6](#). These values are for field installations as specified in the reference manual.

**Table 9.6: Uncertainties for the Rosemount Conditioning Orifice Plate products.**

Beta, $\beta$	Discharge Coefficient Uncertainty with Calibration	Discharge Coefficient Uncertainty without Calibration
<b>1595, 405C</b>		
$0.20 \leq \beta \leq 0.40$	$\pm 0.50\%$	$\pm 1.00\%$
$0.41 \leq \beta \leq 0.5$	$\pm 1.00\%$	$\pm 1.00\%$
$\beta > 0.50^1$	$\pm 1.00\%$	$\pm 1.00\%$
<b>9295<sup>2</sup></b>		
$0.20 \leq \beta \leq 0.40$	$\pm 0.50\%$	$\pm 1.00\%^3$
$0.41 \leq \beta \leq 0.5$	$\pm 0.90\%$	$\pm 1.00\%$
$\beta > 0.50$	$\pm 1.40\%$	$\pm 1.50\%$

<sup>1</sup> For Reynolds numbers < 10000, add an additional 0.50%.

<sup>2</sup> For  $\beta < 0.50$  and  $Re_D < 8000$ , add 0.50%.

For  $\beta > 0.50$  and < 16000, add 1.50%.

<sup>3</sup> For a 2-in. (50 mm) pipe size, add 0.50%.

### 9.5 Rosemount 1195 Integral Orifice Primary Element

Flow meter applications in pipe sizes that are smaller than 2 in. (50 mm) create design challenges. The small size requires a tighter tolerance for critical dimensions of components. Since the Annubar Primary Element and Conditioning Orifice Plate products are not available below a 2-in. (50 mm) nominal pipe size, Emerson offers the Rosemount 1195 Integral Orifice Primary Element. The Rosemount 1195 is pre-installed in a pipe or meter tube for nominal pipe sizes of 0.5, 1, and 1.5 in. (12, 25, and 38 mm) with the single-bore orifice plate positioned and aligned between custom cast housings. To accommodate most applications, either honed pipes with flanges are available or the meter body can be ordered with NPT-tapped openings for threaded pipe.

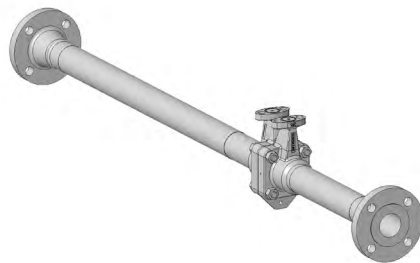
#### 9.5.1 Advantages of the Rosemount Integral Orifice Plate

The Rosemount 1195 Integral Orifice Primary Element provides a simple and accurate solution to measuring a wide variety of fluids in small pipes using a reliable, traditional orifice plate.

Despite the advantages stated previously, small orifice-bore meters are more of a challenge due to the tight tolerances required to fabricate and install the orifice plate. The Rosemount 1195 is designed to minimize the uncertainty of flow measurement by the precise machining of critical features and locating the orifice plate in a meter run or set of pipe spools.

Figure 9.32 shows the Rosemount 1195. The construction is all stainless steel with four bolts to fasten the two castings together at the plate.

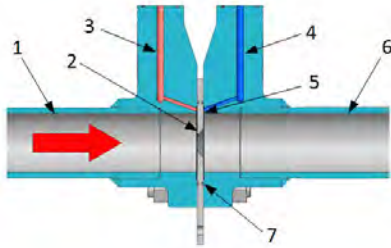
**Figure 9.32: Rosemount 1195 Integral Orifice Primary Element.**



The body casting design provides crucial features for a small-bore orifice meter (see Figure 9.33) such as:

1. The meter tubes are bored after the pipes, and castings are welded for a distance of four pipe diameters from the plate to ensure a consistent and precise inside diameter.
2. A machined feature at the plate provides a slot to read the average pressure around the circumference (piezometer).
3. The gaskets between the plate and castings are O-rings that provide a flush seal to eliminate voids.
4. Holes are drilled to bring the corner tap pressure to the mounting flanges where a transmitter manifold can be mounted directly.

**Figure 9.33: Rosemount 1195 Integral Orifice Primary Element components.**

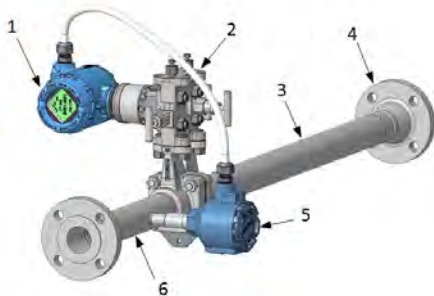


- |                           |                    |
|---------------------------|--------------------|
| 1. Upstream Tube          | 5. Piezometer Slot |
| 2. Orifice Plate and Bore | 6. Downstream Tube |
| 3. High-Pressure Passage  | 7. O-Ring Seal     |
| 4. Low-Pressure Passage   |                    |

### 9.5.2 Integrated DP Flow Measurement for Small Pipes

To complete the small-bore orifice flow meter, Emerson's same Rosemount DP and flow meter product line of transmitters is also available. The model shown in [Figure 9.34](#) is a Rosemount 3051SFP, which is a flow meter that can be fully compensated for pressure and temperature. For temperature compensation, an integral RTD is installed in the downstream spool section.

**Figure 9.34: The integral orifice flow meter.**



- |                                       |                     |
|---------------------------------------|---------------------|
| 1. Rosemount 3051SMV Flow Transmitter | 4. Piping Flange    |
| 2. DP Manifold                        | 5. RTD Housing      |
| 3. Upstream Spool                     | 6. Downstream Spool |

### 9.5.3 A Range of Orifice Bores for Every Application

Since flow rates in smaller pipe sizes can vary greatly, multiple bores for the Rosemount 1195 are offered. [Table 9.7](#) shows the bores by pipe size for the Rosemount 1195. Additional bore sizes are available but may have a longer delivery. Also shown is the actual pipe inside diameter at the bored sections.

**Table 9.7: Rosemount 1195 pipe and available bore sizes.**

Nominal Pipe Size	Actual Pipe ID, in. (mm)	Bore Size Code	Orifice Bore Diameter, in. (mm)
1/2-in. (DN15)	0.664 (16.9)	0066	0.066 (1.68)
		0109	0.109 (2.77)
		0160	0.160 (4.06)
		0196	0.196 (4.98)
		0260	0.260 (6.60)
		0340	0.340 (8.64)
1-in. (DN25)	1.049 (26.6)	0150	0.150 (3.81)
		0250	0.250 (6.35)
		0345	0.345 (8.76)
		0500	0.500 (12.7)
		0630	0.630 (16.0)
		0800	0.800 (20.32)
1 1/2-in. (DN40)	1.61 (40.9)	0295	0.295 (7.49)
		0376	0.376 (9.55)
		0512	0.512 (13.00)
		0748	0.748 (19.00)
		1022	1.022 (25.96)
		1184	1.184 (30.07)

### 9.5.4 Performance

The performance of the Rosemount 1195 is dependent on the orifice bore size. This is due to the limits of machining very small bores into the plate. [Table 9.8](#) shows the uncertainty for the Rosemount 1195 (primary element only) by bore size. In addition to what is in the table, custom bore sizes are available.

**Table 9.8: Rosemount 1195 uncertainty.**

Bore Size — in. (mm)	Discharge Coefficient Uncertainty
<0.160 (4)	±2.50%
0.160 (4) ≤ Bore < 0.500 (12.7)	±1.50%
0.500 (12.7) < Bore < 1.000 (25.4)	±1.00%
1.000 (25.4) < Bore	±1.50%

### 9.6 Traditional Orifice Plate Products

The traditional, single-bore orifice plate is still in use, and Emerson offers two products using this type of orifice plate. In some cases, plant specifications require single-bore orifice plates or state that the flow meter primary device must have a specification from a recognized weights and measures authority, such as ISO or ASME.

#### 9.6.1 Rosemount 405P Compact Orifice Plate DP Flow Meter

The Rosemount 405P orifice plate is identical to the Rosemount 405C except that it has a single bore rather than the four bores for the conditioning plate. The same wafer, alignment ring, and direct-mount head features are standard. The same flow meter options are also available for the Rosemount 405P. [Figure 9.35](#) shows the Rosemount 3051SFC Compact Orifice Plate Flow Meter. The straight pipe length requirements for the Rosemount 405P are much greater than for the Rosemount 405C. See [Chapter 10](#) for more information.

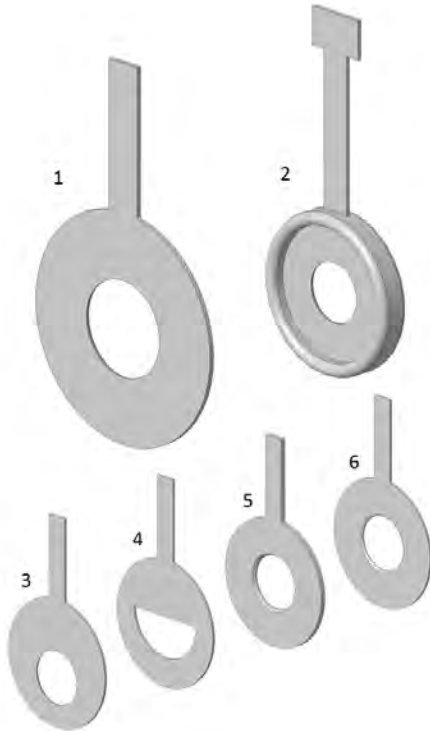
**Figure 9.35: Rosemount 3051SFC Compact Orifice Plate Flow Meter.**



#### 9.6.2 Rosemount 1495 Orifice Plate

The Rosemount 1495 is offered when a traditional orifice plate is needed. The Rosemount 1495 can be supplied for pipe sizes from 2 to 24 in. (50 to 600 mm). Unlike the Rosemount 1595 Conditioning Orifice Plate, the Rosemount 1495 can be ordered with any bore size that represents the range of beta values between 0.10 and 0.70. If desired, Emerson will size the bore to a value that will give the required DP based on the flow rate. See [Chapter 7](#). The universal plate and the four special types of orifice plate bores are also offered for the Rosemount 1495 product (see [Chapter 7](#) for descriptions). [Figure 9.36](#) shows these plate types for the Rosemount 1495 product line. For applications that require it, drain/vent holes in the plate and spiral grooves on each plate surface for improved sealing are also available.

Figure 9.36: Rosemount 1495 orifice plate types.



- |                         |                     |
|-------------------------|---------------------|
| 1. Standard Sharp-Edge  | 4. Segmental Bore   |
| 2. Universal Ring-Joint | 5. Conical Entrance |
| 3. Eccentric Bore       | 6. Quadrant Edge    |

### 9.6.3 Performance

Since the Rosemount 1495 traditional single-bore orifice plate is of a non-proprietary design, the performance is defined in the orifice plate standards mentioned earlier. As explained in [Chapter 7](#), the dimensions and features for fabricating an orifice plate are fully defined. If these specifications are met, and for the Rosemount 1495 they are, then the application range and the uncertainty for the discharge coefficient for that (uncalibrated) plate are listed. For this reason, Emerson does not offer a calibration for the single-bore orifice plate models. The application limits for a concentric, sharp-edged orifice plate are shown in [Table 9.9](#), and the uncertainty is shown in [Table 9.10](#). These limits and performance apply to the Rosemount 405P and Rosemount 1495 products.

Table 9.9: Concentric, sharp-edged orifice plate limits.<sup>1</sup>

For All Taps
$d$ (bore) $\geq$ 12.5 mm (0.50 in) 50 mm (2 in) $\leq$ $D$ (pipe) $\leq$ 1000 mm (39.4 in) $0.10 \leq \beta \leq 0.75$
For Corner and D, D/2 Taps
$Re_D \geq 5000$ for $0.10 \leq \beta \leq 0.56$ $Re_D \geq 16000\beta^2$ for $\beta > 0.56$
For Flange Taps
$Re_D \geq 5000$ and $Re_D \geq 170\beta^2 D$

<sup>1</sup> Adapted from ISO 5167-2:2003.

Table 9.10: Concentric, sharp-edged orifice plate uncertainty to 95% confidence.<sup>2</sup>

Beta, $\beta$	Expanded Uncertainty (95%)
$0.10 \leq \beta \leq 0.20$	$(0.70 - \beta) \%$
$0.20 \leq \beta \leq 0.60$	0.50%
$0.60 \leq \beta \leq 0.75$	$(1.667\beta - 0.50) \%$
If Applicable	Add the Following to the Above
If $D < 2.8$ in (71 mm) If $\beta > 0.50$ and $Re_D < 10000$	$0.9(0.75 - \beta)(2.8 - D(\text{in})) \%$ 0.50%

<sup>2</sup> Adapted from ISO 5167-2:2003.

## 9.7 Rosemount Transmitters

There are five different transmitters within Emerson's Rosemount pressure portfolio that are capable of measuring flow. These five transmitters differ based on performance specifications and availability of specific features. See [Table 9.11](#) for a comparison.

### 9.7.1 Rosemount 2051C, 3051C, and 3051S Transmitters

Rosemount 2051C, 3051C, and 3051S transmitters utilize a differential pressure measurement and can output a flow value by configuring the square-root transfer function and the scaled variable in the transmitter. The scaled variable configuration allows the user to create a relationship between the pressure units and user-defined custom units, in this case, flow units. These three transmitters all utilize a Coplanar





connection platform when measuring differential pressure and can be pre-assembled to manifolds as well as most Rosemount primary elements.

### 9.7.2 Rosemount 3051S MultiVariable Transmitter

The Rosemount 3051S MultiVariable™ transmitter

(3051SMV) can make additional static pressure and temperature measurements in conjunction with differential pressure. The static pressure measurement is taken from a dedicated sensor found on the high-pressure side of the transmitter. The temperature measurement is taken from a temperature element external to the main transmitter body. The Rosemount

**Table 9.11: An overview of Rosemount pressure transmitter specifications.**

Model	2051C	3051C	3051S	3051SMV	4088
					
Flow Calculation Type	Square root of DP	Square root of DP	Square root of DP	Fully Compensated Mass, Energy, and Volumetric Flow	External Flow Computer
Differential Pressure Reference Accuracy	0.065% of span	0.04% of span	Classic: 0.035% of span Ultra: 0.025% of span Ultra for Flow: 0.04% of reading	Classic: 0.04% of span Ultra for Flow: 0.04% of reading	Standard: 0.1% of span Enhanced: 0.075% of span Enhanced for Flow: 0.05% of reading
Rangeability	100:1	150:1	Ultra and Ultra for Flow: 200:1 Classic 150:1	Ultra for Flow 200:1 Classic 100:1	Enhanced for Flow 100:1 Standard 50:1
Diagnostics	Transmitter	Transmitter, Loop Integrity	Transmitter, Loop Integrity, Process Intelligence, Plugged Impulse Line	Transmitter	Transmitter
Protocols	4-20 mA HART®, FOUNDATION™, Fieldbus, WirelessHART®, PROFIBUS®, Low Power 1-5 V HART	4-20 mA HART, FOUNDATION Fieldbus, WirelessHART, PROFIBUS, 1-5 V HART	4-20 HART, FOUNDATION Fieldbus, WirelessHART	4-20 HART, FOUNDATION Fieldbus, WirelessHART <sup>1</sup>	Modbus®, BSAP/MVS
Flow Accuracy	N/A	N/A	N/A	0.65% of reading for 14:1 flow turndown, Flow calculated from DP, SP, and T	N/A
Stability	0.125% or URL <sup>2</sup> for 5 years	0.2% of URL <sup>2</sup> for 10 years	Classic: 0.2% of URL <sup>2</sup> for 15 years Ultra/Ultra for flow: 0.15% of URL <sup>2</sup> for 15 years	Classic: 0.2% of URL <sup>2</sup> for 15 years Ultra/Ultra for flow: 0.15% of URL <sup>2</sup> for 15 years	Standard: 0.1% USL <sup>2</sup> for 1 year Enhanced/Enhanced for flow: 0.125% USL <sup>2</sup> for 5 years
Warranty	Up to 5 years	Up to 5 years	Up to 15 years	Up to 15 years	Up to 12 years

<sup>1</sup>The Rosemount 3051SMV with WirelessHART does not support temperature measurement or output compensated flow.

<sup>2</sup>URL is the upper range limit, and USL is the upper sensor limit.

3051SMV can calculate a fully compensated flow value via the onboard flow computer. This can compensate for a variety of dynamic fluid properties such as the discharge coefficient for Reynolds-dependent meters (e.g., orifice plates), density, and viscosity.

### 9.7.3 Rosemount 4088 MultiVariable Transmitter

The fifth transmitter used in flow applications is the Rosemount 4088 MultiVariable transmitter. This is a multivariable transmitter that is designed for low power applications and is most commonly used in the oil and gas industry. The Rosemount 4088 utilizes a common Modbus protocol and can output process variables to any external flow computer. In addition to Modbus, the Rosemount 4088 can also communicate via Bristol™ Standard Asynchronous/Synchronous Protocol (BSAP)/MVS protocols for seamless integration with Emerson flow computers. It acquires measurements in the same manner as the Rosemount 3051SMV, but it lacks the onboard flow computer. The Rosemount 4088 and 3051SMV transmitters can be pre-assembled to a flange, manifold, or most of the Rosemount primary elements discussed previously. Refer to [Table 9.11](#) to see a comparison of these different transmitters.

### 9.7.4 Rosemount Coplanar Platform

As discussed in [Chapter 7](#), there are two types of transmitter connection platforms: biplanar and Coplanar. While the biplanar style is a common connection platform, all Rosemount brand transmitters use a patented Coplanar connection style. The Rosemount Coplanar™ connection design moves the sensing diaphragms to the bottom of the transmitter, resulting in the diaphragms being on the same plane. This is where the name Coplanar comes from.

Emerson’s family of Rosemount transmitters can be assembled with a few different manifolds and flanges. The standard connection with a transmitter is the Coplanar flange. If a manifold is needed, the Rosemount 305 Coplanar manifold will replace the Coplanar flange entirely.

Some applications may require a Rosemount transmitter to be retrofitted to an existing biplanar installation. In these cases, Emerson offers a traditional flange and manifold. This is beneficial for existing installations or to keep process connections consistent. A traditional flange can take the place of the Coplanar flange and, if needed, a conventional manifold can then be assembled to the traditional flange. See [Table 9.12](#) for an overview of connection types.

**Table 9.12: Rosemount flanges and manifolds.**





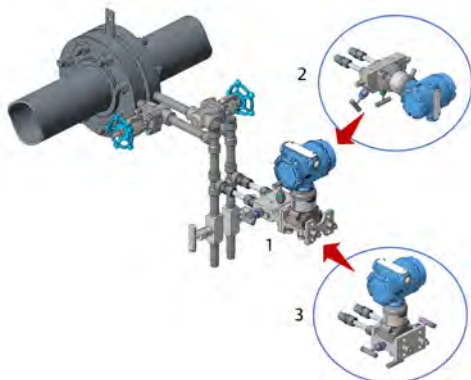
				
Process Connection Type	Traditional Flange	304 Conventional Manifold	Coplanar Flange	R305 & 305 Coplanar Manifold
Valving Configurations	Drain vents	3-valve, 5-valve	Drain vents	3-valve, 5-valve
Benefits	Industry connection	Ability to connect to process by flange or threads	Reduced weight and size for flexible installation	Many valve options; can be used without a flange
Challenges	Large size and heavy	Requires a traditional flange	Threaded-only process connection	Threaded-only process connection



Figure 9.37 shows a comparison of traditional DP flow installations using Coplanar manifolds and conventional manifolds.

Figure 9.37: Traditional DP meter system piping with various Rosemount manifolds.



1. Traditional Flange with Rosemount 304 Conventional Manifold
2. Rosemount 305RC Coplanar Manifold
3. Rosemount 305RT Coplanar Manifold

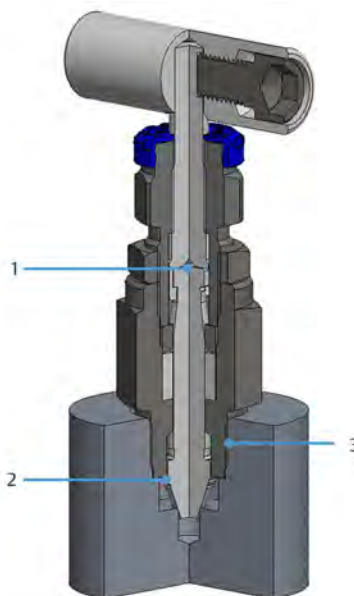
The benefit of the Coplanar platform is that it is lighter due to less material, requires a simpler installation, and reduces the amount of leak points.

Additionally, Emerson offers a higher performing manifold known as the Rosemount R305, which enhances performance and total operation life. This manifold exclusively features Pressure-Lock™ Valve technology that provides increased operator safety, enhanced reliability, and simplified operation via the ergonomic usage of valve operation.

These benefits are provided by the valve's two-piece stem design, which eliminates a large amount of internal friction due to a non-rotating valve stem tip. The safety back seating provides integral blowout protection for increased operator safety. In addition, the stem and bonnet threads are isolated from the process fluid, thus increasing equipment life and improving corrosion resistance and safety. There is also a larger internal process bore, which provides increased resistance to plugging.

Additional details about the Rosemount R305 Coplanar Manifold Pressure-Lock Valve are shown in Figure 9.38.

Figure 9.38: Rosemount Pressure-Lock Valve.



1. Two-Piece Stem Design with Non-Rotating Tip
2. Safety Back Seating
3. Bonnet Threads Isolated from Process Fluid

### 9.7.5 Rosemount Performance

Performance is a combination of several factors, notably transmitter accuracy, stability, and susceptibility to the application and environment. Transmitter performance can be impacted by many different physical and environmental conditions such as severe temperature variation, overpressure events, and harsh environments. At the heart of Emerson's Rosemount 3051S and MultiVariable transmitters is a high-performance, pressure-sensing module called a SuperModule™, which contains the primary analog electronics, characterization data values, and sensing element. See Figure 9.39.

**Figure 9.39: Rosemount 3051S SuperModule.**



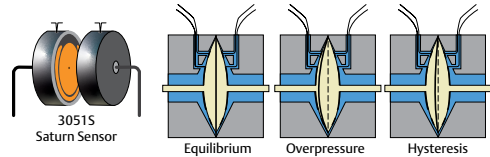
The SuperModule enables a more reliable, repeatable measurement due to rigorous, industry-proven quality standards and manufacturing processes. The Rosemount SuperModule seeks to reduce impacts on stability through its all-welded, hermetically sealed design. The hermetic seal and highly engineered isolating diaphragms also protect the transmitter from the harshest environments.

The SuperModule also provides superior stability. Stability is usually specified as a percent of the URL over a given time. Rosemount Ultra for Flow transmitters, described in [Section 9.7.5.2](#), have a stability specification of 0.15% of URL for 15 years. This means that over the course of 15 years, the transmitter's output will not drift more than 0.15% of the URL. For example, consider a transmitter with a URL of 100 inH<sub>2</sub>O (24.88 kPa) that has been properly zeroed. If the same input is applied to the transmitter over the course of 15 years, excluding all other sources of error, the transmitter reading would never be greater than 100.15 inH<sub>2</sub>O (24.92 kPa) or less than 99.85 inH<sub>2</sub>O (24.85 kPa). This apparent error is the result of the natural transmitter drift, quantified by the stability specification.

An additional source of error can come from an overpressure event. Overpressure events can happen when only one valve of a DP system is open to pipe pressure, a manifold valve sequence is done incorrectly, or the applied DP is much larger than the URL of the transmitter. This can significantly impact the sensor and result in a transmitter output shift, which reduces

accuracy. To mitigate this effect, Emerson developed Saturn™ Sensor technology, which has five electrical connections and an additional set of capacitors as shown in [Figure 9.40](#). This provides extra sensor compensation, resulting in improved performance in both accuracy and repeatability.

**Figure 9.40: Rosemount 3051S Saturn Sensor.**



As previously mentioned, the Saturn Sensor directly mitigates the effect of overpressure. The secondary sensor will maintain the ratio between the actual pressure measurement and the secondary capacitors. The relationship between these sensors is known at reference conditions so when an overpressure event occurs, the sensor will remain accurate and repeatable.

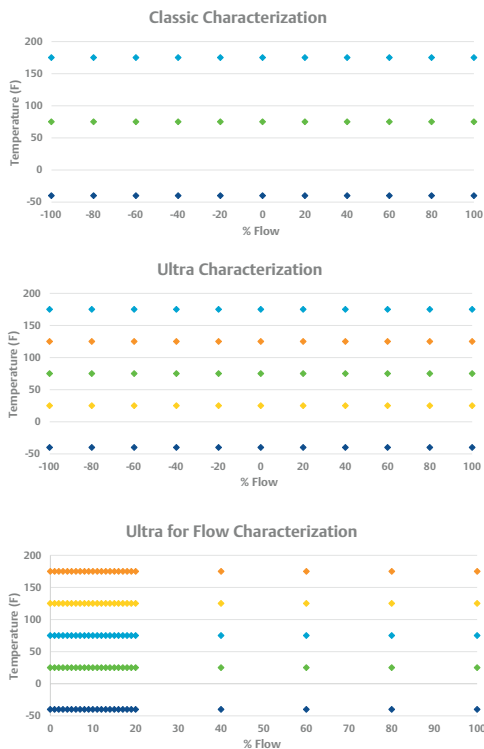
### 9.7.5.1 Manufacturing Processes

Manufacturing to 3-sigma ensures that 99.7% of all units produced will meet or exceed their performance requirements. Technology leadership, advanced manufacturing techniques, and statistical process control ensure specification conformance of Rosemount transmitters to at least 3-sigma. Due to these robust and strictly controlled manufacturing processes, every transmitter is assembled to order, leak checked, and factory calibrated with National Institute of Standards and Technology (NIST) traceable instruments. There is a plethora of additional procedures and testing available to meet any industry requirement, including, but not limited to, National Association of Corrosion Engineers (NACE) certification, hydrostatic testing, hazardous area certification, and cleaning for special service. Additionally, Emerson produces transmitters to meet accuracy specifications specific to the transmitter model being produced. Emerson's Rosemount transmitters do not get sorted into distinct categories based on performance, but every unit

gets its performance built-in through Emerson's characterization and verification (C/V) process. For example, every Rosemount 3051S module is built to a designated performance class: classic, ultra, or Ultra for Flow.

The C/V process exposes the transmitter to real world conditions, examines each transmitter individually, and develops a set of unique transmitter parameters that are permanently associated with that unit. This individual attention is what allows units to be intentionally differentiated from one another. As shown in [Figure 9.41](#), transmitters with the Ultra for Flow performance class undergo significantly more manufacturing time than either the classic or ultra performance classes.

**Figure 9.41: Rosemount transmitter performance class characterization.**



The Ultra for Flow chart clearly contains many more characterization points of the sensor in the low flow region. This enables the percent of

reading specification at a 14:1 flow turndown. Before performance class specifics can be discussed in more detail, it is important to understand the differences between a percent of reading accuracy specification and percent of calibrated span.

### 9.7.5.2 Rosemount Transmitter Accuracy

Accuracy is commonly specified as a percent of calibrated span.

#### Example:

A 0 to 1000 inH<sub>2</sub>O calibrated span transmitter with 0.04% of span accuracy will have an error limit of  $\pm 0.4$  inH<sub>2</sub>O over the entire 1000 inH<sub>2</sub>O span.

In this example,  $\pm 0.4$  inH<sub>2</sub>O is a minor error at the 1000 inH<sub>2</sub>O upper range, but it becomes more significant as the measurement moves towards the lower end of 10 inH<sub>2</sub>O.

As the calibrated span is adjusted, the error changes accordingly.

#### Example:

If the same transmitter previously spanned 0 to 1000 inH<sub>2</sub>O is re-spanned and re-calibrated 0 to 200 inH<sub>2</sub>O, the new error limit will be  $\pm 0.08$  inH<sub>2</sub>O across the new span of 0 to 200 inH<sub>2</sub>O.

Calibrating the span specific to the application helps improve overall accuracy but limits the range that the transmitter can accurately measure.

Another classification of transmitters that exist in the market today is percent of reading. This specification is exactly what it sounds like: the accuracy of the transmitter is a percent of what the reading is.

#### Example:

A 0.04% of reading specification on a 1000 inH<sub>2</sub>O transmitter will have an error limit  $\pm 0.4$  inH<sub>2</sub>O at 1000 inH<sub>2</sub>O.

A key difference from a percent of span transmitter is that a percent of reading transmitter will have the same error in percent of reading as the reading decreases or the error in DP will decrease as the reading decreases.

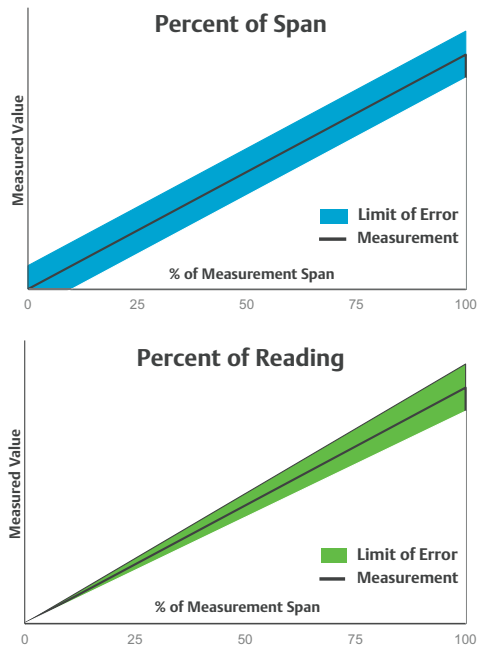
### Example:

A 0.04% of reading transmitter spanned at 1000 inH<sub>2</sub>O measuring 200 inH<sub>2</sub>O will have an error limit of ±0.08 inH<sub>2</sub>O.

Recall from the earlier example that a 0.04% of span, 0 to 1000 inH<sub>2</sub>O transmitter would have an error limit of ±0.4 inH<sub>2</sub>O across the entire range. This means its error limit at 200 inH<sub>2</sub>O would also be ±0.4 inH<sub>2</sub>O, whereas a similarly spanned percent of reading transmitter will have an error limit of only ±0.08 inH<sub>2</sub>O at 200 inH<sub>2</sub>O.

This is beneficial because the error limits will always be based on the transmitter reading and not the calibrated span. Percent of reading transmitters require a less specific calibrated span, ultimately allowing the transmitter to be used in a wider variety of applications. See [Figure 9.42](#) to see a comparison of a percent of reading vs percent of span.

**Figure 9.42: A graphical comparison between percent of reading and percent of span accuracy over the entire flow range.**



Note that there is a minor shift in the percent of reading accuracy past 10:1 DP turndown. This change is reflected by a formula that can be referenced in the transmitter's product data sheet.

The Rosemount 3051S and 3051S MultiVariable have a percent of reading performance class called Ultra for Flow as shown in [Table 9.13](#). This performance class allows for percent of reading accuracy over a 14:1 flow turndown or 200:1 DP turndown. Ultra for Flow enables accurate measurement over wide ranges but especially at lower flow rates. This eliminates the need for stacking transmitters and swapping orifice plates, and it allows standardization on one transmitter for a wide variety of applications.

### 9.7.6 Multivariable Flow Measurement

From [Chapter 3](#), the equation for calculating the volumetric and mass flow rate for an area meter is:

$$Q_v = NCY_1 d^2 E \sqrt{\Delta P / \rho}$$

$$Q_m = NCY_1 d^2 E \sqrt{\Delta P \rho}$$

Where:

- $Q_v$  Volumetric flow rate
- $Q_m$  Mass flow rate
- $N$  Conversion factor
- $C$  Discharge coefficient
- $Y_1$  Gas expansion factor
- $d$  Area meter bore
- $E$  Velocity of approach factor
- $\Delta P$  Differential pressure
- $\rho$  Fluid density

Clearly there are many different parameters that directly impact the flow calculation. In DP flow applications, the only three measurable flow variables needed to calculate compensated flow are differential pressure, static pressure, and process temperature. Multivariable transmitters

**Table 9.13: A direct comparison of the Rosemount 3051S percent of reading accuracy with a percent of span transmitter. Note: the percent error shown is only the reference accuracy for the DP measurement.**

% Span				Ultra for Flow	
0.04% of Span		Flow Turndown	DP Reading (inH <sub>2</sub> O)	0.04% Reading	
Error (±inH <sub>2</sub> O)	% Error			Error (±inH <sub>2</sub> O)	% Error
0.4	0.04%	1:1	1000	0.4	0.04%
0.4	0.16%	2:1	250	0.1	0.04%
0.4	0.40%	3:1	100	0.063	0.063%
0.4	1.60%	6:1	25	0.033	0.13%
0.4	4%	10:1	10	0.027	0.27%
0.4	8%	14:1	5	0.025	0.50%
0.4	40%	33:1	1	0.0234	2.34%

can measure these three variables with one device by incorporating dedicated differential pressure and static pressure sensors as well as an input from an RTD. While the most accurate calculation is achieved from all three measurements, some applications require less. For example, certain applications might have a stable process temperature and can be accurately measured with only differential pressure and static pressure. Rosemount MultiVariable transmitters can be customized with any combination of the three measurements to best suit the given application.

In addition to this scalability, the Rosemount 3051S MultiVariable transmitter also includes an onboard flow computer. [Figure 9.43](#) shows a flowchart of how the Rosemount 3051SMV takes measured values and outputs compensated mass, volumetric, or energy flow. Calculating flow based on variable parameters requires a significant amount of computational horsepower that cannot be accomplished entirely in the transmitter. Certain parameters such as fluid type, line size, and primary element need to be configured prior to operation. For Rosemount brand transmitters, this configuration is done using a standalone program called Engineering Assistant (EA). EA contains a database of over 125 fluids and an extensive list of primary elements.

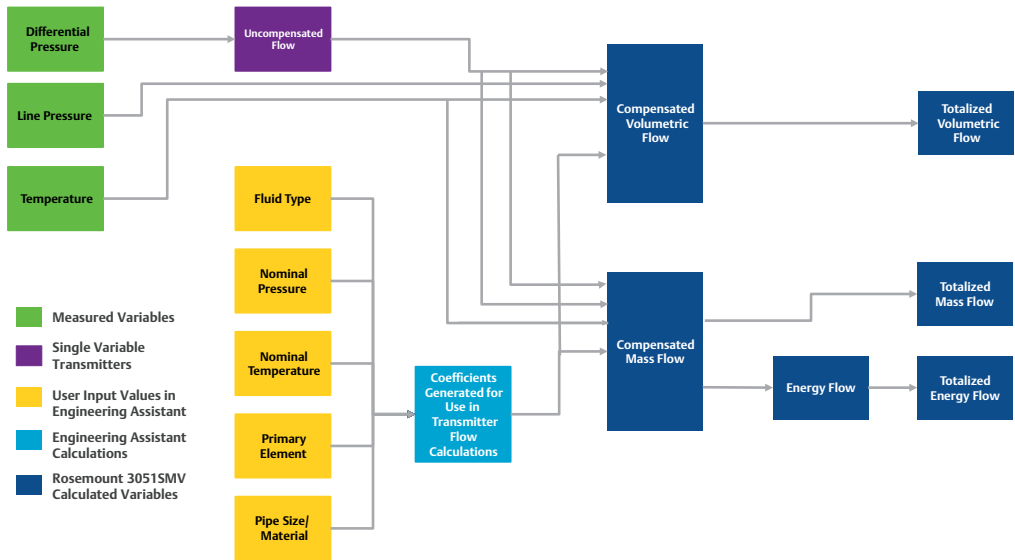
EA is used to generate specific coefficients for the transmitter to use in its flow calculations. These coefficients are determined by the unique set of inputs from the user as shown in [Figure 9.43](#)

and are based on industry standard equations of state. The selection of the fluid identifies the reference equations EA will use for calculating the various fluid properties required for calculation of the flow rate. These equations are taken directly from the Design Institute for Physical Properties Research (DIPPR) Database. In addition, certain fluid properties such as the compressibility factor require additional reference equations. EA will use a couple different equations for compressibility based on the fluid such as NIST14, AGA Detail Characterization Method, or Redlich-Kwong. If a specific fluid is not stored in EA's database, user-defined custom fluids can also be configured.

Additionally, EA uses specific equations for primary elements based on many standards including ISO, AGA, and ASME. More specifically, EA uses the Reader-Harris Gallagher equation from AGA Report No. 3 to calculate the discharge coefficient for orifice plates. As the industry standards change, Emerson continues to improve Engineering Assistant with the most up-to-date reference equations.

In addition to initially configuring a Rosemount 3051SMV for flow, EA makes it easy to re-configure the transmitter, such as when it is necessary to swap orifice plates, adjust for seasonal flow, or allow for a change in fluid composition. Once the Rosemount 3051S MultiVariable transmitter is fully configured, it will calculate flow 22 times per second using the measured values to compensate for dynamic fluid

Figure 9.43: Flowchart of how the Rosemount 3051SMV calculates compensated mass, volumetric, or energy flow.



properties such as density and viscosity.

### 9.7.7 Rosemount Advanced Diagnostics

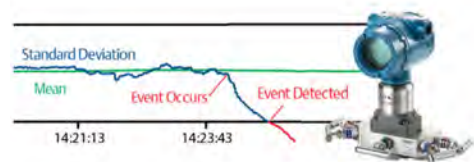
In comparison to standard transmitter diagnostics that monitor specifically for device failure, Rosemount Advanced Diagnostics extend diagnostic coverage beyond the transmitter, monitoring from the process to the host system. By using this additional information from the device, users can proactively identify potential process upsets, simplify maintenance routines, and identify process optimization opportunities. Rosemount brand pressure transmitters offer several distinct advanced diagnostic functions.

#### 9.7.7.1 Process Intelligence

Process Intelligence uses a patented statistical processing technology for the early detection of abnormal situations in the process environment that may affect operations and safety. It works by baselining and proactively monitoring the noise level of the specific application as seen in Figure 9.44. A change in this noise level could signify an issue in the process, equipment, or process connections. Process Intelligence can be used to detect issues such as furnace flame instability,

pump cavitation, distillation column flooding, agitation loss, and more.

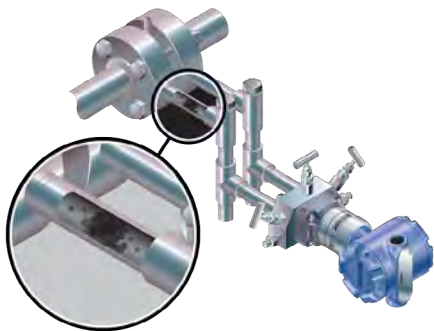
Figure 9.44: Rosemount Process Intelligence diagnostic.



#### 9.7.7.2 Plugged Impulse Line

The Plugged Impulse Line diagnostic uses a patented statistical processing technology to detect plugged impulse lines, as shown in Figure 9.45, or other process connection issues, such as plugged pressure taps. Plugging impulse lines can be tricky to detect. It effectively blocks the pressure signal, making it unresponsive to changes. Left unchecked, this can reduce plant efficiency and product quality. The Plugged Impulse Line diagnostic helps proactively identify process connection issues and optimizes preventative maintenance schedules by eliminating unnecessary maintenance.

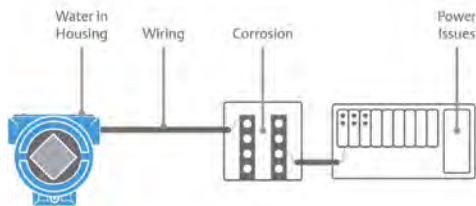
**Figure 9.45: Rosemount 3051S Plugged Impulse Line diagnostic.**



### 9.7.7.3 Loop Integrity

Loop Integrity continuously monitors for changes in the 4-20 mA loop that may signify that an incorrect measurement is being communicated in the control room. The electrical loop is critical for communication between the process and control room, but over time, environmental and human stresses on loop infrastructure can put the reliability of the 4-20 mA loop at risk. Issues such as corrosion or water in the terminal compartment can easily remain hidden until impact to process operations or safety is realized. With Loop Integrity, a hidden loop issue can be identified by an affect in their reading and take early corrective action. See [Figure 9.46](#) for an overview of Loop Integrity.

**Figure 9.46: Rosemount Loop Integrity diagnostic.**



### 9.7.7.4 Additional Diagnostics

Here are some additional diagnostics:

- **Diagnostics Log** — Records up to ten device status events with a time stamp for simplified troubleshooting.
- **Variable Log** — Records extreme process pressure and sensor temperature events with a time stamp for enhanced insight into device health.
- **Process Alerts** — Monitors process pressure and sensor temperature values against user-configured settings to identify problematic conditions.
- **Service Alerts** — Generates a customized service reminder message after a specified window of time.

Additionally, Rosemount Advanced Diagnostics are certified for use in Safety Instrumented Systems (SIS). SIS certification is available on many Rosemount transmitters. For more information on SIS certification and what applications typically require it, see [Section 8.9](#).

Rosemount pressure Advanced Diagnostics technology is housed in the transmitter, so diagnostic messages can be accessed in multiple ways. An analog control system or digital communication protocol, such as HART and FOUNDATION Fieldbus, can be used to monitor diagnostics. Emerson AMS Device Manager or another asset management system can give access to even richer diagnostic information. If using wireless communication, diagnostic data and messages can be integrated into the existing wireless network by outfitting the transmitter with an Emerson Wireless 775 THUM™ Adapter. For local diagnostic indication, an LCD display can be added to the transmitter.

Rosemount Advanced Diagnostics identify potential process upsets, simplify maintenance routines, and identify process optimization opportunities. Since different communication protocols utilize different technologies, exact advanced diagnostic functionality varies across

protocols. Consult the product data sheets and/or reference manuals for availability on a particular product.

### 9.8 Additional Information

For more information on Emerson's Rosemount DP flow products, go to [Emerson.com/DPFlow](https://www.emerson.com/DPFlow) or consult your local Emerson representative. Rosemount primary elements and transmitters each have a series of documents to assist with specifying, ordering, installing, maintaining, and troubleshooting the products:

- Product Data Sheet (PDS) – Product specifications, order matrix, dimensional drawings, and certifications.
- Quick Start Guide – Minimum information for installing and operating a flow meter.
- Reference Manual – Contains installation and maintenance guidelines.

These documents can be found on [Emerson.com/DPFlow](https://www.emerson.com/DPFlow).



# 10

## DP Flow Meter Installation

	<b>Topic</b>	<b>Page</b>
10.1	Introduction	210
10.2	Essentials	210
10.3	Primary Element Planning	213
10.4	Primary Element Location	221
10.5	Primary Element Orientation	225
10.6	Impulse Piping for Remote Mount Applications	229
10.7	Flow Meter Installation	231
10.8	Special Installation Considerations	233
10.9	In-Situ Calibration Using Pitot Traverse	240
10.10	Commissioning	242
10.11	Installation Checklist	244
10.12	Additional Information	245

## 10 DP Flow Meter Installation

### 10.1 Introduction

**Important note:** This chapter examines the installation of differential pressure (DP) flow devices at a high level. **It is not intended as a complete guide for installation.** Every installation is unique in some way. There are three types of documents available for each type of Emerson’s Rosemount™ DP flow meter:

1. Product Data Sheet (PDS) — Product specifications, order matrix, dimensional drawings, and certifications.
2. Quick Start Guide — Minimum information for installing and operating a flow meter.
3. Reference Manual — Installation, operation, startup, commissioning, troubleshooting, specifications, and reference information.

Every standard product is shipped with a Quick Start Guide. Each guide provides a step-by-step process for installation specific to each type of flow meter. All product documents can be found online at [Emerson.com/DPFlow](http://Emerson.com/DPFlow).

### 10.2 DP Flow Meter Installation Essentials

The priorities for a successful flow meter installation are:

1. Install the flow meter safely.
2. Prevent meter and equipment damage.
3. Optimize flow meter performance.

#### 10.2.1 Safety Concerns

Safety of personnel in the vicinity should be the primary installation concern. Ensure that piping is depressurized and cool to the touch before attempting any modification. Required lock-out/tag-out procedures should be done on pumps and valves to prevent any re-pressuring of the system during installation. Personnel should be trained in the use of the required tools and equipment, and a safety representative should

be available during all fabrication operations.

Proper installation is critical to ensuring that the pressure-retaining capability of the instrument is maintained. Always follow the steps outlined in the Quick Start Guides and reference manuals.

The instrument engineer who specified the flow meter should be consulted if there are any questions regarding the suitability or application of the flow meter in the plant.

Consider the weight of the flow meter before installation. Heavy or large components may require a crane or hydraulic lift. When possible, mount meters at grade level for safe access.

These may not be the only safety concerns. All local plant procedures should be followed during flow meter installation.

#### 10.2.2 Preventing Flow Meter Damage

A flow meter must be installed with forethought and care in order to prevent damage to the instrument and associated piping. Proper specification and configuration of the flow meter components will avoid many application issues, but proper installation and startup is also required.

##### 10.2.2.1 Mechanical Damage

Care must be exercised when handling DP flow meters. The proper operation of DP flow meters relies on the geometry of the local piping and flow meter components, and on the finish of the exposed meter surfaces. Damage or alteration to the edges and surfaces of most DP flow primary elements will compromise the performance. For Emerson’s Rosemount Annubar™ primary elements, the mechanical advantage of the mounting hardware fasteners can cause damage to the sensor by over tightening, which may bend or twist the element. Install the Annubar primary element as directed in the Quick Start Guide.

*Figure 10.1* shows a Rosemount 485 Annubar that was damaged during installation most likely due to over tightening.

**Figure 10.1:** Rosemount 485 Annubar Primary Element damaged by improper installation.



The sharp edge of orifice plate bores must not be damaged. An orifice plate should never have any object inserted into the bore or set on surfaces that could damage the bore. The front surface of the plate must also meet the specification for surface finish. [Figure 10.2](#) shows an orifice plate bore edge and front surface that was damaged by mishandling. When installed, the orifice plate must be properly centered. Conditioning Orifice Plates must have the taps oriented so that they are between any two bores. For some product options, the taps may need to be oriented to the upstream fitting.

**Figure 10.2:** Damage on an orifice plate front surface and edge.



### 10.2.2.2 Process-Related Damage

Flow-generated damage can be caused by pressure, temperature, fluid type, water hammer, thermal shock, or flow-induced vibration (for an averaging pitot tube). Any of these conditions can cause failure of a flow meter. Consult the meter sizing calculation, which includes a maximum flow rate that must not be exceeded. For Annubar Flo-Taps, a lower flow rate maximum must be observed during insertion and retraction of the Annubar flow meter.

### 10.2.2.3 Flow Meter Materials

Material selections must be made with the process fluid and conditions in mind. Industrial processes often involve corrosive or abrasive materials. Care must be taken to ensure all components in an assembly are compatible with the process fluid conditions. Some applications, including steam, will subject the primary element and mounting hardware to high fluid temperatures and pressures. If an application involves chlorides, they can degrade common stainless steels when subjected to high temperatures. Primary elements may develop stress corrosion cracks when subjected to these types of environments. All components must be rated to the maximum temperature and pressure and be compatible with the chemicals the system will be exposed to.

Very cold temperatures, such as cryogenic applications, will make materials more brittle. Low-carbon or nickel-based stainless steels as well as aluminum and titanium alloys can be used for temperatures as low as  $-150^{\circ}\text{F}$  ( $-100^{\circ}\text{C}$ ). Consult your local Emerson representative for available materials.

### 10.2.2.4 Ambient Conditions

Exposure of the transmitter electronics to temperatures above  $185^{\circ}\text{F}$  ( $85^{\circ}\text{C}$ ) will reduce the lifespan and lead to a failed system. Cold ambient temperatures can present challenges as well. When the transmitter temperature falls below  $-40^{\circ}\text{F}$  ( $-40^{\circ}\text{C}$ ), the response time of the transmitter becomes unacceptably long for the

application. Care should be taken to protect the transmitters from cold environments. Year-round ambient temperatures should be verified at the planned location for the transmitter. When insulating, care must be taken that the degree of heat dissipation will not cause overheating in the warmer months or over cooling in the winter months. The transmitter can be moved away from the primary element location to avoid temperature extremes by using longer impulse piping or tubing with the remote mount option. Impulse lines and transmitters exposed to cold climates may require heat tracing and/or insulation to keep the process fluid above the freezing point. For some outdoor applications, the DP impulse tubing and transmitter can be placed in a heated enclosure. If a line or process is shut down in cold weather, the heat system needs to be left on or the meter, tubing, and valves cleared of process fluid. See [Section 10.3.7](#) for more details on heat tracing.

### 10.2.3 Optimizing Flow Meter Performance

A flow meter will only achieve the rated performance if it is configured, installed, and operated correctly. Measurement errors can occur if the primary element is not installed per specification. The following guidelines should be followed to achieve optimum performance:

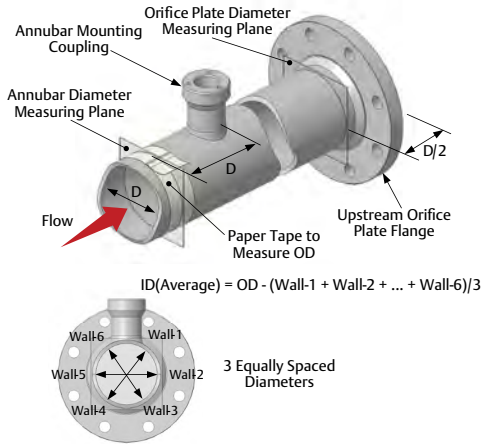
- The appropriate length of straight pipe from the upstream disturbance (such as an elbow) should be provided or straightening vanes installed upstream of the flow meter.
- The flow primary element should be ordered as calibrated to obtain the best accuracy. The DP transmitter is usually calibrated, and it can be provided with a certificate if needed.
- For all DP primary elements, the pipe inside diameter (ID) should be measured after the mounting hardware is welded to the pipe. See [Figure 10.3](#) or [Section 10.2.3.1](#).
- Provisions are made to zero trim the transmitter, and if needed, to remove or isolate the transmitter for calibration verification.

- The flow meter is installed according to the instructions, and the primary element is aligned within specification.

#### 10.2.3.1 Measuring the Pipe

The pipe ID measurement for an Annubar primary element is made at a distance of one pipe diameter upstream of the primary element, and for an orifice plate, a ½-pipe diameter upstream of the flange. The pipe ID is measured at two or more evenly spaced diameters, and the values are averaged. For an orifice plate, the condition of the upstream piping should meet the specification in the standards. The measured diameter should then be applied to the flow meter configuration. [Figure 10.3](#) shows the location for measuring the pipe ID for an orifice plate and an Annubar primary element using a three-diameter measurement. The best tool for doing this is a bore gauge. If the pipe interior cannot be accessed or a bore gauge for the pipe size is not available, the pipe ID can be calculated. Measure the pipe average outside diameter (OD) using a thin paper tape wrapped around the unobstructed pipe to get the circumference, and then divide by  $\pi$  (i.e., 3.1416). The pipe wall thicknesses are measured using an ultrasonic thickness gauge at the end points for the diameters. Each pipe ID is then calculated by subtracting the two opposing wall thicknesses from the pipe OD, or using the equation shown in [Figure 10.3](#).

**Figure 10.3: Measuring the pipe ID.**



## 10.3 Installation Planning

The following are the primary considerations when planning a flow meter installation:

- Application type
- Primary element mounting
- DP or flow transmitter mounting configuration
- Temperature limits
- Vibration limits
- Process fluid
- Heat tracing
- Steam applications
- Wiring

### 10.3.1 Application Type

To properly assess what is needed for a flow meter installation, the purpose of the measurement should be reviewed. If performance is a priority, then the planning should include the items shown in [Section 10.2.3](#). If reliability and low maintenance are a priority, then provisions to prevent degradation of meter operation should be included. This chapter

shows the typical and recommended methods for installing the flow meter. These methods will provide long-term operation within specifications and minimize maintenance.

### 10.3.2 Primary Element Mounting

The DP primary element must be mounted in the pipe, so it should be specified and built for the pipe size it is to be installed in. For most applications, the meter size is the same as the pipe size, but it is possible for the two sizes to be different if the effects of expansion or reduction of pipe fitting are taken into account. Check the tag for the pipe ID that the meter was built to. Special considerations may be needed for certain applications where pipe access is restricted such as a pipe in a pipe rack or a buried pipe. Ideally, the measurement location will be indoors and in a place that is convenient for instrument technicians to access, but this is not always possible. If provisions have been made to remove the primary element while under pressure, periodic inspection can be done without a system shutdown. See [Section 10.8.1](#) for more information on hot tapping.

Emerson’s Rosemount primary elements have several different mounting styles for each type of meter. The basic primary element mounting styles are described in this section.

#### 10.3.2.1 Spool-Mounted Meter

Spool meters contain a section of pipe and typically have piping flanges on both ends of the meter or utilize threaded or welded ends for installation. The spool can be as short as two pipe diameters or as long as 20 or more pipe diameters. The length of the spool must be accommodated in the plant piping and the appropriate fittings welded or otherwise attached to allow the meter to be mounted. [Figure 10.4](#) shows a Rosemount 9295 with spool meter mounting. Appropriate gaskets, threaded studs, and nuts are required to complete the installation shown.

Figure 10.4: Spool-mounted meter.

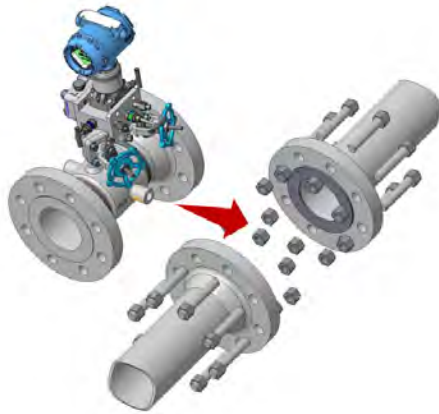
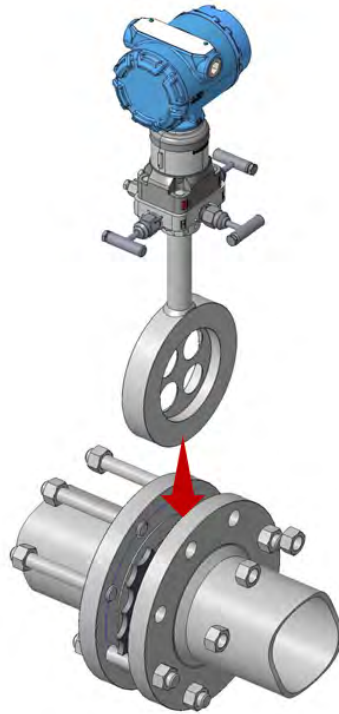


Figure 10.5: Wafer-mounted meter.



### 10.3.2.2 Wafer-Mounted Meter

A wafer-mounted meter contains a disk that has a bore equal to the standard pipe ID and an outside diameter that will fit inside the bolting studs of a flange. The wafer is thick enough to accommodate the primary element and is designed to be sandwiched between two flanges. [Figure 10.5](#) shows a wafer flow meter being mounted between flanges. If the meter is to be retrofitted between existing flanges, they must be at least 1.5 in. (38 mm) apart to allow installation. The meter should be centered so that the wafer bore lines up with the flange bores. Emerson supplies an alignment ring to assist with meter centering.

### 10.3.2.3 Insert-Mounted Meter

An insert meter is mounted through a hole in the existing piping using a threaded or flanged coupling that is welded to the pipe. The primary element includes hardware to fasten it securely to the coupling. See [Figure 10.6](#). For an Annubar primary element, the size of the hole drilled into the pipe is specific to the sensor size used. If the hole is too large, the performance can be compromised. Contact your Emerson representative for assistance with adjusting the output. See the Quick Start Guide for the correct drill size.

**Figure 10.6: Insert-mounted meter.**



### 10.3.3 DP or Flow Transmitter Mounting

Once the primary element is mounted to the pipe, the DP or flow transmitter needs to be installed. The terms direct mount and remote mount are used to describe how a transmitter is connected to the primary element. For a direct mount meter, there is little planning to do for mounting the transmitter. For the remote mount meter, the location for the transmitter needs to be determined and the required valves, tubing, and other components collected to complete the installation.

#### 10.3.3.1 Direct Mount

A direct mount DP flow meter has the transmitter connected directly to a DP primary element. See [Figure 10.7](#). This type of meter ships preassembled since the primary element and transmitter are installed together as one component. There is no impulse piping, as the impulse lines are incorporated into the primary element. This reduces installation and maintenance costs, as well as safety hazards due to fewer potential leak points.

**Figure 10.7: A direct mount DP flow meter does not require impulse piping or separate valves.**



Use of this design is a best practice for long-term performance and reduced maintenance as long as the process temperature is less than 450 °F (232 °C). The close coupling of the transmitter requires that the temperature at the transmitter be carefully monitored. At process temperatures above 450 °F (232 °C), the transmitter should be mounted remotely at a distance far enough from the process to ensure that the electronics temperature does not exceed 185 °F (85 °C). Care must be taken when bleeding a DP flow system to prevent over temperature. The meter should always be isolated from the process before the system is equalized. Emerson offers several types of fully integrated, direct mount flow meters. See [Chapter 9](#) for more information.

#### 10.3.3.2 Remote Mount

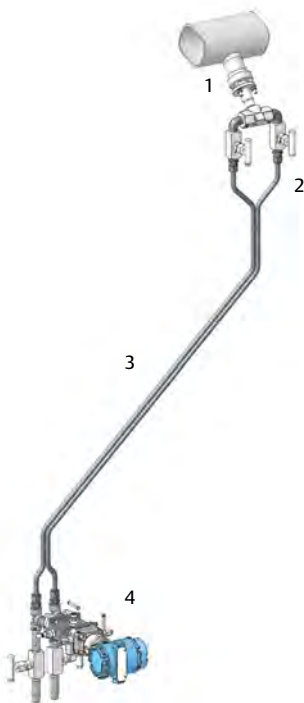
Remote mounting may be necessary when:

- The process temperature exceeds the limitations of a direct mount transmitter.
- The primary element does not have the option for a direct mount (such as a traditional or Rosemount 1595 Conditioning Orifice Plate).
- It is necessary to position the transmitter at a different location than the primary element.

**Note:** For any fluid temperature above 185 °F (85 °C), the equalizer valves should not be opened without isolating the transmitter first. This can cause fluid to flow through the impulse tubing and manifold and heat up the transmitter.

An example of a remote mount installation is shown in [Figure 10.8](#). One advantage of mounting the transmitter remotely is that it can be located indoors or in an enclosure and positioned for optimum commissioning and maintenance procedures. Emerson's family of Rosemount primary elements can be ordered for a remote mount installation.

**Figure 10.8:** An example of a remote mount installation in a liquid application.



1. Primary Element and Horizontal Pipe
2. Stainless Steel 1/2-in. (DN 15) OD Tubing
3. High and Low Tubing Run Together at Constant Slope
4. DP Transmitter with Manifold and Blow-Down Valves

Impulse lines should only be as long as necessary to minimize leak points and ensure heat dissipation from hot process conditions. Impulse lines should be installed with a constant slope containing no high or low spots. For gas applications, the transmitter should be mounted above the primary element, and there should

not be any low spots in the impulse tubing where liquid could collect. In liquid applications, the transmitter should be installed below the primary element, and there must not be any high spots where air or gas could collect (i.e., entrained air). An accuracy shift can occur in either scenario. When it is not possible to follow these guidelines, collection chambers, pots, and/or additional valving can be installed at appropriate points in the impulse tubing to periodically eliminate collected condensate or gases. For steam applications, impulse lines should be installed so that they will fill with condensate to prevent the transmitter from contact with high temperature steam. The need for insulation is determined by the local temperature and location of the flow meter. Insulating piping and fittings to provide optimum thermal conditions requires an understanding of the temperatures and insulation properties. Consult trained personnel if unfamiliar with insulating systems. See [Section 10.6](#) for more information on mounting the DP transmitter remotely.

### 10.3.4 Temperature Limits

Process temperature should be checked against the maximum primary flow element limits. Check the values on the tag attached to the product. Fluid temperatures above 400 °F (204 °C) require optional high temperature packing in valves and a Flo-Tap packing gland, if used. Check the specifications for the flow meter under consideration to verify process compatibility.

### 10.3.5 Vibration Limits

Process vibration should be considered prior to installing a flow measurement point. In high vibration applications, care should be taken to ensure that the physical limits of both the primary element and electronics are not exceeded. Direct mount flow meters with the transmitter mounted at the end of the meter stem can fail due to oscillations creating repeated stress. Tubing and conduit will flex and may also fail if the tubing is not secured and the vibration levels are high enough. See the PDS or reference manual for vibration limit specifications.



## 10.3.6 Process Fluid

Most process fluids are clean, single-phase, and homogeneous. However, there are applications where the liquid or gas includes solids or are two-phase fluids (i.e., entrained gases in a liquid or liquid suspended in a gas).

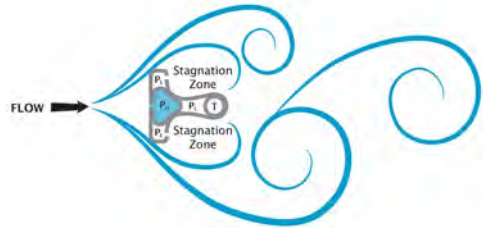
### 10.3.6.1 Particulate Accumulation

Particulate-laden flows can present challenges for DP flow metering. Recommendations differ based on the fluid and type of fouling particles present.

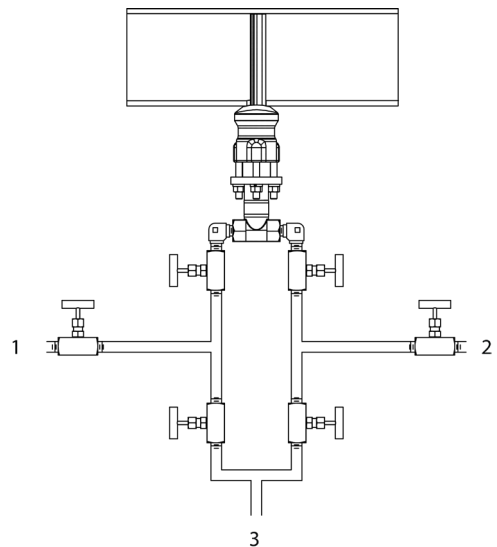
In applications with particulates in the flow stream, an Annubar flow meter can provide some resistance to clogging due to the T-shape design. Stagnation pressure zones in front and in back of the T-shape help prevent particulates from flowing into these areas, keeping them clear. See [Figure 10.9](#). All solids suspended in a liquid are not the same. Smaller and/or lighter particulates may find their way into the small passages of a flow primary element. Larger or sticky particulates may collect on the bottom of the pipe or on the exposed surfaces of the primary element. All applications of this type require periodic inspection of the primary element. The Annubar Averaging Pitot Tube can be equipped with an intermittent purge system using compressed air or nitrogen to regularly clear particulates from internal passages.

[Figure 10.10](#) shows the arrangement of impulse piping to allow periodic purging of the Annubar primary element. Intermittent purge systems are typically automated and are set up to isolate the DP transmitter from the purge pressures.

**Figure 10.9: Annubar sensor fluid dynamics.**



**Figure 10.10: Arrangement of impulse piping for intermittent purge.**



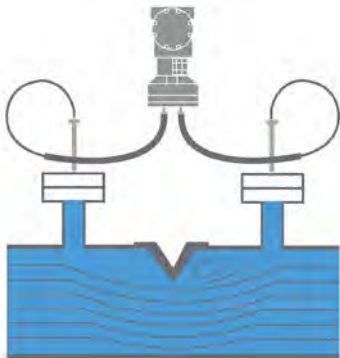
1. To High Side of Secondary Element
2. To Low Side of Secondary Element
3. To External Source for Purge Fluid

Concentric orifice plates should not be used for dirty or particulate-laden fluids. The eccentric or segmental orifice plates can be used for this type of application. See [Chapter 7](#). Applications with abrasive particulates should not be used with any sharp-edged orifice plate. A quadrant-edged orifice should be used in this case.

A wedge primary element can be a great option for slurries, dirty flows, and other challenging process conditions. When used with remote seals, the need for impulse lines is mitigated

along with any plugging concerns. [Figure 10.11](#) shows a schematic of this type of installation. See [Chapter 7](#) for more information on the wedge primary element.

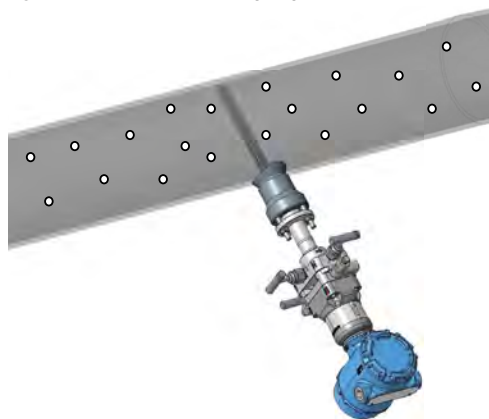
**Figure 10.11: Wedge primary element installation using diaphragm seals for the DP transmitter interface.**



### 10.3.6.2 Gas Entrapment for a Liquid Flow

In liquid process flow, gas bubbles may be present. The entrained gas forms bubbles in the process fluid and enter a DP flow meter. These trapped bubbles may interfere and cause measurement error. This is generally not a problem if the orientation of the primary element is appropriate (i.e., below the horizontal plane) for typical fluid velocities. [Figure 10.12](#) shows a properly oriented Annubar primary element in a liquid application with gas bubbles present. For other meter mounting arrangements, it may be necessary to periodically vent the system to prevent the accumulation of unwanted gases. Special impulse-piping arrangements can help simplify this maintenance. See [Section 10.6](#).

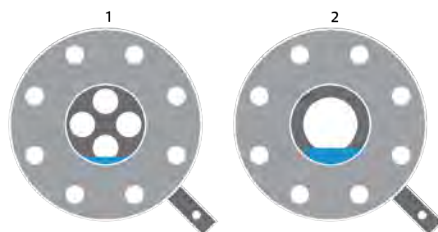
**Figure 10.12: Gas-entrained liquid flow.**



### 10.3.6.3 Liquid Accumulation for a Gas Flow

In gas applications, liquids (i.e., condensables) may also collect where they are not desired. A benefit of the Conditioning Orifice Plate is that it can be used to avoid issues with these types of flows. With the 4-bore pattern, the Conditioning Orifice Plate can be oriented in such a way so that the entrained gases or liquids pass easily through the holes in the 6 o'clock or 12 o'clock position without affecting the measurement. [Figure 10.13](#) shows a Conditioning Orifice Plate oriented for wet gas service and a traditional orifice plate for the same conditions.

**Figure 10.13: A conditioning and traditional orifice plate mounted in a horizontal pipe for wet gas service.**

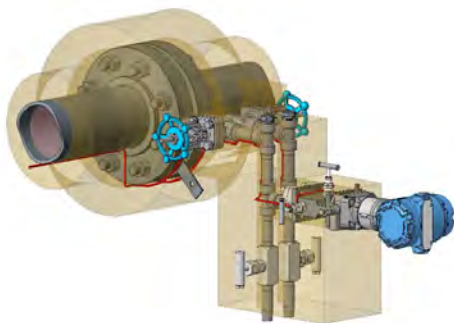


1. Conditioning Orifice Plate
2. Traditional Orifice Plate

### 10.3.7 Heat Tracing

Heat tracing is used in cold ambient temperatures to prevent liquid systems from freezing. See [Figure 10.14](#). It typically uses electricity or steam tubing in combination with insulation to maintain temperature. Heat tracing adds additional costs to a flow meter installation. It is important that the heat-tracing system be monitored or thermostatically controlled to avoid under or overheating the system. Direct mounting, weather-tight enclosures, or indoor installations should be used whenever possible to minimize heat tracing costs and simplify the installation.

**Figure 10.14:** Heat tracing of an orifice plate flow meter.



### 10.3.8 Steam Applications

The success of a DP meter on steam service relies on the relative temperature of the components. This is affected by the ambient temperature, which can be extreme (summer/winter) if the unit is outside. Also, the proper distance from the pipe is needed to keep the impulse piping from freezing but not so close as to cause over temperature. An example of a meter with insulation around the primary element and a portion of the piping is shown [Figure 10.15](#). The steam DP flow meter installation depends on the type of primary element, pipe orientation, and type of DP transmitter mounting. See [Sections 10.5.1](#) and [10.6](#). The DP generated for a steam flow is conveyed through water-filled impulse piping and works when the high and low sides of the meter maintain a consistent liquid level.

See [Chapter 6](#). Caution must be used if there is a shutdown. The isolation valves should be closed to prevent the water from boiling out of the system due to the vacuum created in the piping. Also, without the heat from the pipe, some outdoor systems can freeze and damage the sensing diaphragms of the transmitter. Systems that start up and shut down often interrupt thermal equilibrium and may require thermostatic heat tracing and/or special procedures to ensure a successful installation. See [Section 10.8.5](#) for information on high temperature steam installations.

**Figure 10.15:** Direct mounted Rosemount 3051SFC wireless flow meter on an exterior steam application where the steam temperature is 365 °F (186 °C).



### 10.3.9 Wiring

To understand the wiring practices that are common in process control applications, it is important to understand a 2-wire versus a 4-wire installation, the different types of wires used, conduits and cable trays, transient protection, and grounding.

#### 10.3.9.1 2-wire vs. 4-wire

In a 2-wire installation, the wires carry the communication signal and enough current to power the instrument. In a 4-wire installation, two wires carry the communication signal, and two separate wires are used to power the instrument. A 4-wire installation is necessary when the current in a 2-wire loop is not strong enough to carry the communication signal and

power the instrument. The cost for wiring a 4-wire instrument is higher than that of a 2-wire instrument, especially if the instrument requires 110V or 220V AC power.

### 10.3.9.2 Types of Wire

Typical industrial wiring practices require shielded wire, multiwire, or twisted pair wires. Refer to the PDS and/or reference manual for wiring requirements such as minimum gauge or maximum wire length. *Figure 10.16* shows several types of wire.

- Shielded wire uses a metal covering that prevents the wires from picking up radio frequency (RF) and other electromagnetic signals. The metal covering, or shield, must be grounded for maximum signal protection. It is best to ground only one end of the cable shield.
- Multiwire refers to multiple wires contained in a single sheath. Four-wire meter systems would use this type of wire. In applications that require multiple wires, using multiwire reduces wiring costs.
- Twisted pair wire refers to a pair of wires that are twisted to prevent RF interference. When a twisted pair wire encounters an RF signal, both wires pick up the RF signal at equal strength but in the opposite direction. These two RF signals cancel out, resulting in little or no interference.

**Figure 10.16: Examples of different types of wires. Different installations may require different wires.**



### 10.3.9.3 Conduits and Cable Trays

Conduits are metal or plastic tubes, either solid or flexible, that are used to protect insulated wires. Conduits are usually required in areas where wires are exposed to potential damage. If grounded correctly, a conduit can serve as an RF shield. Cable trays look like metal ladders and are either suspended from the ceiling or fastened to the wall. Cable trays are used to contain and route long runs of wiring. *Figure 10.17* shows a cable tray and conduit. Wiring in cable trays is usually left unprotected other than each wire's sheath of insulation. To avoid potential interference, power and signal wiring should never be run together in the same cable tray.

**Figure 10.17: Conduit and cable tray.**

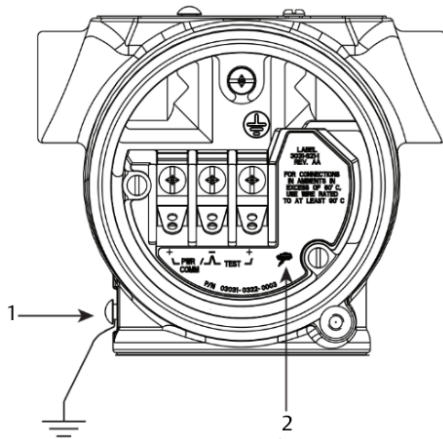


### 10.3.9.4 Transient Surge Protection

A transient surge is a short-term, high excess of voltage or current in an electrical circuit. Lightning, welding, heavy electrical equipment, and switch gears are common sources of transients. When a transient occurs in a circuit, any electrical equipment connected to the circuit could be damaged or destroyed. Measurement and control instruments are especially susceptible to transients because they contain sensitive electronic components. A transient protector in a transmitter application limits the impact of a transient on the transmitter.

Transient protection devices are available as replacement terminal blocks or as completely independent products. A transient protection terminal block is typically only available as an option from the instrument provider, and it replaces the standard terminal block in the instrument as shown in [Figure 10.18](#). An independent transient protection device is installed on the field wire, independent of the instrument, and routes the transient around the instrument using a bypass wire. For the transient protection components in the terminal block to work properly, the transmitter must be grounded.

**Figure 10.18: Sample transient-resistant terminal block.**



1. External Ground Location
2. Lightning Bolt Location

### 10.3.9.5 Grounding

A ground is a conducting connection between an electrical circuit or equipment and the earth or some conducting body that functions in place of the earth. A ground provides a safe path for the dissipation of fault currents, lightning strikes, static discharges, electromagnetic interference (EMI), and RF interference.

## 10.4 Installation Location

The placement of the flow meter in a piping branch is called location. A proper installation location provides the straight run requirements for the given piping to ensure accurate and repeatable flow measurements. The pipe fitting(s) upstream of the flow meter creates a flow disturbance that affects the flow profile, which can compromise the performance. [Figure 10.19](#) shows a typical piping branch with a flow meter. Straight run requirements are different for each style of primary element. For Annubar primary elements, straight run also depends on the orientation of the sensor. The value of the straight piping is given in pipe diameters. For example, an indicated straight run of four for a 4-in. (100 mm) diameter pipe is 16 in. (400 mm). These values are based on:

- The source of the flow disturbance upstream
- The type of primary element
- The beta ratio of the primary element (in some cases)

**Figure 10.19: A piping branch and flow meter located.**



These requirements will provide a consistent and accurate flow measurement under typical flow conditions. [Tables 10.1](#) and [10.2](#) show recommended straight pipe run values for six different types of upstream fittings.

**Note:** These tables contain values for straight pipe lengths for the more common piping fittings, but it doesn't cover all available options. Refer to the appropriate Quick Start Guide or reference manual for more information. The Rosemount 1495 Orifice Plate installation is governed by ASME/ISO standards; see applicable standards based on the application. The Rosemount primary element product models are listed in [Table 10.1](#) and [Table 10.2](#) as follows:

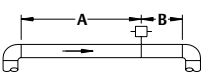
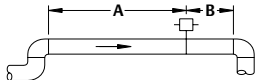
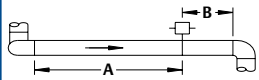
- Primary Elements — Rosemount 485, 405A, and 585
- Conditioning Orifice Plates — Rosemount 405C, 1595, and 9295
- Traditional Orifice Plates — Rosemount 405P and 1495
- Integral Orifice Primary Element — Rosemount 1195

## 10.4.1 Rosemount 485, 405A, and 585 Annubar Primary Elements

The location requirements for the Rosemount 485, 405A, and 585 Annubar Primary Elements are shown in the top row of [Tables 10.1](#) and [10.2](#). The information in these tables applies to the following model types:

- Rosemount 485 Annubar Primary Element — Flanged, Flanged Flo-Tap, Flange-Lok, Pak-Lok, and Threaded Flo-Tap
- Rosemount 585 Severe Service Annubar Primary Element — Flanged, Flanged Flo-Tap, and Main Steam with Opposite Side Support
- Rosemount 405A Compact Annubar Primary Element

**Table 10.1: Straight pipe requirements for piping elbows.**

Primary Element									
	Single Elbow			2 Elbows in Plane			2 Elbows Out of Plane		
	Upstream Diameters		Downstream Diameters	Upstream Diameters		Downstream Diameters	Upstream Diameters		Downstream Diameters
	In Plane A	Out of Plane A	B	In Plan A	Out of Plane A	B	In Plane A	Out of Plane A	B
Averaging Pitot Tube <sup>1</sup>	8	10	4	11	16	4	23	28	4
Conditioning Orifice Plate <sup>2</sup>	2	2	2	2	2	2	2	2	2
Traditional Orifice Plate <sup>3</sup>	$\beta = 0.20$	6	4	10	6	19	6	6	6
	$\beta = 0.40$	16	6	10	6	44	6	6	6
	$\beta = 0.50$	22	6	22	6	44	6	6	6
	$\beta = 0.60$	42	7	42	7	44	7	7	7
	$\beta = 0.65$	44	7	44	7	44	7	7	7
	$\beta = 0.75$	44	8	44	8	44	8	8	8
Integral Orifice Plate <sup>4</sup>	$\beta = 0.20$	24	10	25	10	30	10	10	10
	$\beta = 0.40$	25	10	27	10	31	10	10	10
	$\beta = 0.50$	25	10	28	10	33	10	10	10
	$\beta = 0.60$	27	10	31	10	37	10	10	10
	$\beta = 0.70$	32	10	35	10	42	10	10	10
	$\beta = 0.75$	35	10	38	10	45	10	10	10

<sup>1</sup> See [Section 10.4.1](#)  
<sup>2</sup> See [Section 10.4.2](#)  
<sup>3</sup> See [Section 10.4.3](#)  
<sup>4</sup> See [Section 10.4.4](#)

The following notes apply to the information in [Tables 10.1](#) and [10.2](#):

- For square or rectangular ducts, use the equivalent round diameter. See [Chapter 3](#).
- In plane A means the sensor is in the same plane as the elbow. Out of plane A means the sensor is perpendicular to the plane of the elbow. See [Figure 10.20](#).
- If proper lengths of straight run are not available, position the mounting such that 80% of the run is upstream and 20% is downstream. This could result in degraded accuracy that can be addressed with an inline calibration.
- Use straightening vanes to reduce the required straight run length. See Quick Start Guides for more information.
- Column 3 in [Table 10.2](#) applies to gate, globe, plug, and other throttling valves that are partially opened, as well as control valves.
- For full-port ball or gate valves that are fully open, use single-elbow values.

**Table 10.2: Straight pipe requirements for other fittings.**

Primary Element		Pipe Reducer		Pipe Expansion		Valve	
		Upstream Diameters	Downstream Diameters	Upstream Diameters	Downstream Diameters	Upstream Diameters	Downstream Pipe Diameters
		A	B	A	B	A	B
Averaging Pitot Tube <sup>1</sup>		12	4	18	4	30	4
Conditioning Orifice Plate <sup>2</sup>	$\beta = 0.40$	2	2	2	2	2	2
	$\beta = 0.50$	2	2	2	2	2	2
	$\beta = 0.65$	2	2	5	2	2	2
Traditional Orifice Plate <sup>3</sup>	$\beta = 0.20$	5	6	10	6	12	2
	$\beta = 0.40$	5	12	10	8	12	3
	$\beta = 0.50$	8	20	22	9	12	3
	$\beta = 0.60$	9	26	42	11	14	3.5
	$\beta = 0.65$	12	28	44	14	18	3.5
Integral Orifice Plate <sup>4</sup>	$\beta = 0.75$	13	36	44	18	24	4
	$\beta = 0.20$	24	10	25	10	30	10
	$\beta = 0.40$	25	10	27	10	31	10
	$\beta = 0.50$	25	10	28	10	33	10
	$\beta = 0.60$	27	10	31	10	37	10
	$\beta = 0.70$	32	10	35	10	42	10
	$\beta = 0.75$	35	10	38	10	45	10

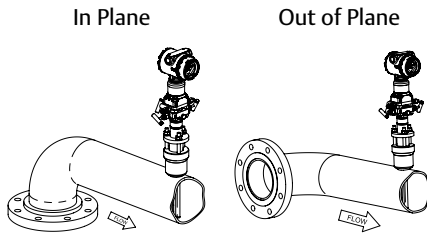
<sup>1</sup> See [Section 10.4.1](#)

<sup>2</sup> See [Section 10.4.2](#)

<sup>3</sup> See [Section 10.4.3](#)

<sup>4</sup> See [Section 10.4.4](#)

**Figure 10.20: Flow meter mounting in plane and out of plane.**



### 10.4.2 Rosemount 1595, 405C, and 9295 Conditioning Orifice Plates

The location requirements for the Conditioning Orifice Plate are shown in the second row of [Tables 10.1](#) and [10.2](#). For some disturbances, the straight pipe is based on the beta ratio.

- For the Rosemount 1595 Conditioning Orifice Plate, the taps must be located between any two bores.
- For best results, the taps for the Conditioning Orifice Plate should be oriented to a plane perpendicular to the upstream pipe elbow.
- Flow straighteners are not needed for the Conditioning Orifice Plate.
- Column 3 in [Table 10.2](#) refers to a butterfly valve that is 75-100% open.

### 10.4.3 Rosemount 1495 and 405P Traditional Orifice Plates

Traditional orifice plate models are covered in row 3 of [Tables 10.1](#) and [10.2](#). The straight pipe requirements depend on the value of the orifice beta ratio (i.e., bore diameter divided by the pipe diameter). There is no plane orientation for traditional orifice plates. See ISO 5167-2 for a more detailed table of values and information on using flow straighteners to reduce the straight pipe requirements. Interpolation for beta values in between those in the tables is allowed.

### 10.4.4 Rosemount 1195 Integral Orifice Primary Element

The bottom row from [Tables 10.1](#) and [10.2](#) show the straight pipe lengths required for the Rosemount 1195. This product comes in several configurations that affect the installation. The Rosemount 1195 can be ordered with integral upstream and downstream pipe spools with either flanged, beveled ends (for welding), or NPT-threaded ends, or without any pipe spools. The optional spools are 18 and 8 diameters long, respectively. The additional lengths needed based on [Tables 10.1](#) and [10.2](#) would be the result of subtracting these lengths from those in the tables for the appropriate piping arrangement. As with the traditional orifice plate, the required straight pipe lengths increase as the bore (and beta) increase. Interpolation for beta values in between those in the tables is allowed.

### 10.4.5 Flow Straighteners

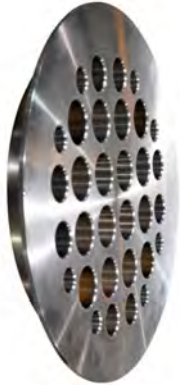
Flow straighteners remove most of the asymmetry and eliminate the swirl found in undeveloped flow fields. There is still a requirement of two to four diameters of straight pipe from the straightener to the flow meter. Flow straighteners are placed upstream of a flow meter allowing for shorter pipe run requirements, which can be especially useful when a long straight pipe run is not available. Two types of flow straighteners are shown here: the 19-tube bundle in [Figure 10.21](#) and the plate straightener in [Figure 10.22](#). The tube bundle is recommended by the American Gas Association (AGA) and is four to six pipe diameters long. The plate straightener takes up less space and is easier to install. See ISO 5167-2, AGA Report No. 3, and ASME MFC-3 for more specific information on using flow straighteners.



Figure 10.21: 19-Tube bundle flow straightener.



Figure 10.22: Plate-style flow straightener.



## 10.5 Installation Orientation

After the proper flow meter location is determined, it must be oriented to provide the most optimum and maintenance-free operation. The DP signal from the primary element must be conveyed to the DP transmitter through a single-phase fluid in the high- and low-side impulse piping. For a typical liquid or gas installation, almost any orientation will work. However, over a long period of time, things will change, and a proper installation will help prevent changes in the system from causing an error in reading later on. It is also necessary to orient the flow meter in a specified way to allow the system for some applications to function, such as for a vertical steam pipe.

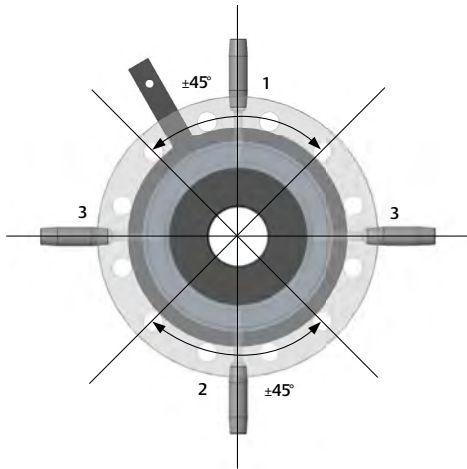
### 10.5.1 Fluid Type

The first orientation directive is by fluid type. Most industrial fluids contain trace amounts of other types of fluids. Water will always have some dissolved air or other gases, and air or gas will contain some amount of water or other liquid vapor. Over a period of time, these fluids will come out of solution and collect. This is especially true when there is a change in temperature or pressure in the system. Since the flow meter creates a pressure drop and can act as a heat sink, these trace fluids can collect around or within the flow meter. Installations that do not conform to standard practices may require draining or venting to remove unwanted fluid buildup. For a steam application, there is the added challenge of maintaining the vapor-liquid interface. Since the DP transmitter would be damaged by direct contact with the steam vapor, it is isolated from the steam by using a water fill. The water-steam interface conveys the DP while keeping the transmitter within operating temperature limits.

#### 10.5.1.1 Gas Applications

For gas applications, the best orientation is for the taps, head, or top works to be above the pipe within  $\pm 45^\circ$  of the vertical, as shown in [Figure 10.23](#) as position 1. This allows for any condensable fluids to escape the flow element. If an orientation with the taps above the pipe is not possible, special impulse piping can be used. See [Section 10.6](#). If there is a chance that added liquids or sediment may be in the bottom of the pipe, the primary element taps should be oriented off the vertical to allow this material to pass. If this orientation is not possible, special impulse piping can be used. See [Section 10.6](#).

**Figure 10.23: Traditional orifice plate tap orientation.**



#### 10.5.1.2 Liquid Applications

For liquid applications, the best orientation is for the taps, head, or top works to be below the pipe within  $\pm 45^\circ$  of the vertical, as shown in [Figure 10.23](#) as position 2. This provides that any collection of gases will come out of the primary element or not otherwise become trapped in the meter. If there is a chance that sediment could be present at the bottom of the pipe, the primary element should be oriented off the vertical to allow them to pass. If this orientation is not possible, special impulse piping can be used. See [Section 10.6](#).

#### 10.5.1.3 Steam Applications

For steam applications in horizontal pipes, traditional DP flow primary elements use a vapor seal (i.e., wet leg) system. In a vapor installation, steam vapor is conveyed to the impulse piping, which typically requires gate or ball through-port valves as primary shutoff, or root, valves. A seal is formed using water in the lower section and DP transmitter. The taps are oriented as shown in [Figure 10.23](#) as position 3. [Figure 6.6](#) in [Chapter 6](#) shows the wet leg system for a horizontal pipe. For vertical pipes, the taps are at different vertical heights, so fittings are required to bring the lower tap to the level of the upper tap. See [Figure 6.8](#) in [Chapter 6](#).

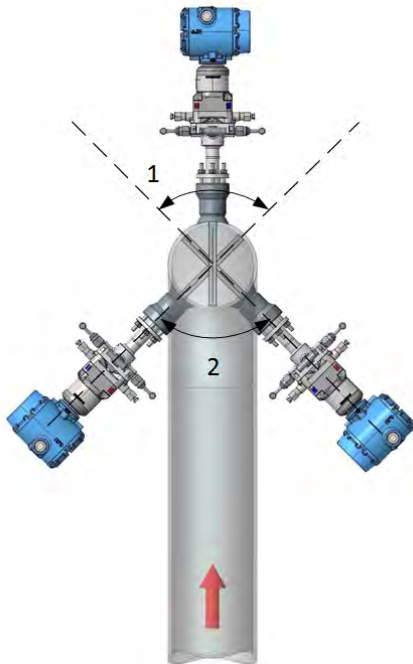
An important point to note about steam is that the point of condensation in DP meter impulse piping is dependent on the local temperature, which is determined by the steam energy and the length of exposed uninsulated tubing. Steam that is at a temperature above saturation (i.e., superheated steam) will require longer distances from the pipe to ensure condensing of the steam will occur at the appropriate point. Conversely, steam that is at a temperature lower than the saturation temperature (i.e., wet steam) will be prone to condensing in the pipe, which can create an inconsistent vapor-liquid interface.

### 10.5.2 Annubar Primary Elements

The orientation recommendations for the Rosemount 485 and 585 Annubar Primary Elements represented here are illustrated showing the Rosemount 485 Annubar Pak-Lok assembly, as this is the most common model, but they also apply to the Flanged, Flanged Flo-Tap, Flange-Lok, and Threaded Flo-Tap models. Refer to the Quick Start Guides for specific information.

The Annubar sensor orientation is similar to the traditional DP devices shown before with the head or top works oriented as shown in [Figure 10.24](#). However, for steam applications in a horizontal pipe, the primary element can be installed similar to liquid service. This is called a condensate system where the meter taps are installed below the pipe centerline, and the DP is conveyed through water legs to the DP transmitter. This is possible because the high/low tubes in the primary element are bonded together and remain at the same temperature. Through-port valves are not required.

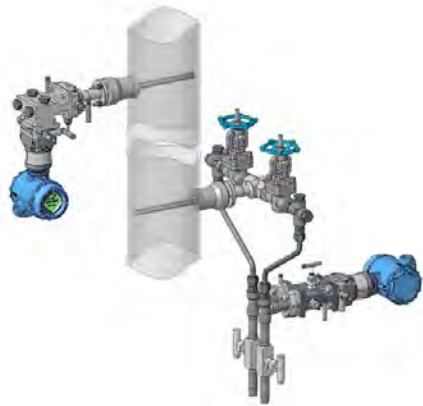
**Figure 10.24: Annubar flow meter orientation by fluid type.**



1. Gas Service
2. Liquid and Steam Service

For vertical pipes, all systems are vapor, as there is no other way to keep condensate in the primary element. A special 90-degree spacer is used to orient the direct mount DP transmitter below the head. For a remote mount, the traditional wet leg system of impulse piping is used. [Figure 10.25](#) shows both methods.

**Figure 10.25: Flow meter mounting for a vertical steam pipe: direct mount (left) and remote mount (right).**



### 10.5.2.1 Flow Meter Orientation to the Upstream Fitting

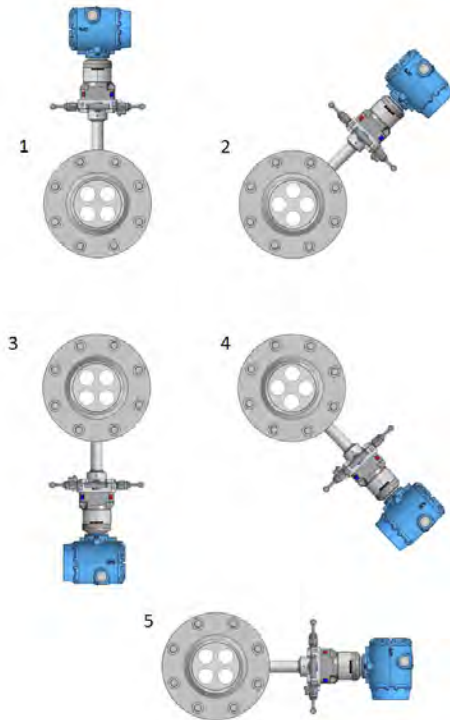
As shown in [Figure 10.20](#), the flow meter in position 1 is in plane with the upstream elbow while the others are not. The required straight run of pipe for these orientations would be different. As was mentioned in [Section 10.5.1](#), the priority for flow meter requirements should be assessed and a decision made as to the orientation needed. An in-plane orientation to the upstream fitting may not be optimal for the given fluid application.

### 10.5.3 Conditioning Orifice Plates

Conditioning Orifice Plates are slightly different than traditional orifice plates in that there is an orientation of the plate due to the four bores. [Figure 10.26](#) shows the alignment preference for Conditioning Orifice Plates. For all Conditioning Orifice Plates, the taps are located between any two bores. For the Rosemount 405C and 9295, that orientation is built in, but for the Rosemount 1595, the plate needs to be oriented as described during installation. For the best performance (i.e., the least amount of shift in the discharge coefficient), the taps are oriented 90° to the plane of the upstream fitting. Flange

bolting may restrict orientation as the taps or meter top works must protrude between any two bolts. As with the Annubar primary element, a decision may be needed when there are conflicting orientation requirements. For smaller beta plates ( $\beta \leq 0.50$ ), however, upstream fitting orientation has little effect, so the fluid condition orientation can be used. For a vertical pipe, there is no orientation based on fluid type except for a steam application, in which case the DP transmitter must be below the meter primary element.

**Figure 10.26: Orientation for the Conditioning Orifice Plate in a horizontal pipe.**



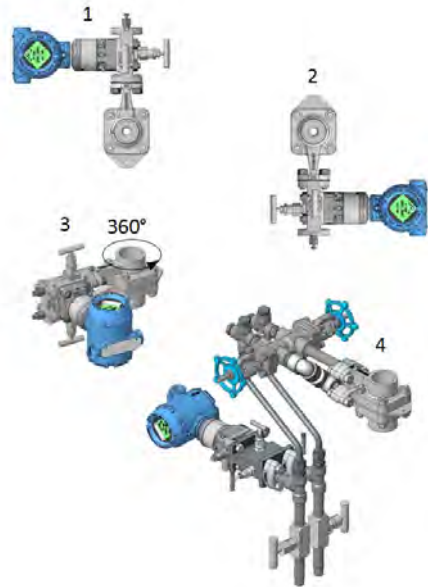
1. Upstream Fitting in Horizontal Plane – Dry Gas Applications
2. Liquid Present in Gas Applications
3. Upstream Fitting in Horizontal Plane – Liquid and Steam Applications
4. Gas Present in Liquid Application or High Condensate Present – Steam Application
5. Upstream Fitting in Vertical Plane – Gas or Liquid Applications

## 10.5.4 Traditional Orifice Plates

For the traditional orifice plate, there is no plane associated with the single bore. [Figure 10.23](#) demonstrates the proper tap orientation.

For the Rosemount 1195 Integral Orifice Primary Element, the taps are integral to the meter casting and should be oriented according to [Figure 10.27](#). For a vertical pipe in a steam application, the wet leg system of impulse piping is used.

**Figure 10.27: Orientation for the Rosemount 1195 with pipe and flanges removed for clarity.**



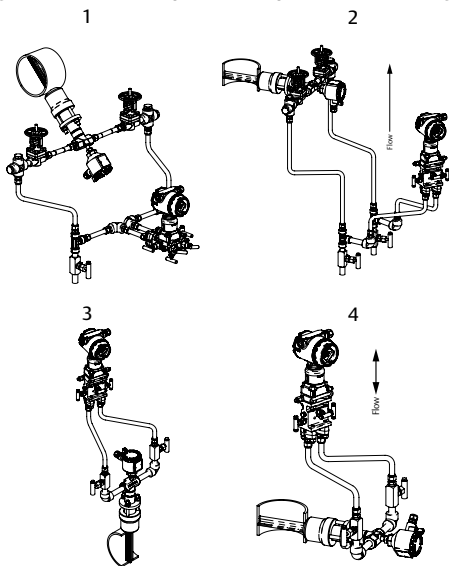
1. Gas Applications
2. Liquid or Steam Applications
3. Vertical Pipe – Gas or Liquid Applications
4. Vertical Pipe – Steam Applications

## 10.6 Impulse Piping for Remote Mount Applications

Remote mount flow meters are selected due to application requirements or because the direct mount system is not available. Impulse piping arrangements are done to comply with the requirements of orientation and transmitter location needed. The recommended remote mount impulse piping arrangements are shown in the next three figures. *Figure 10.28* shows Annubar insert-style primary elements, *Figure 10.29* shows Rosemount 405 platform primary elements, and *Figure 10.30* shows standard orifice plates. Special impulse piping arrangements are required for the following configurations and are shown in *Figure 10.31*:

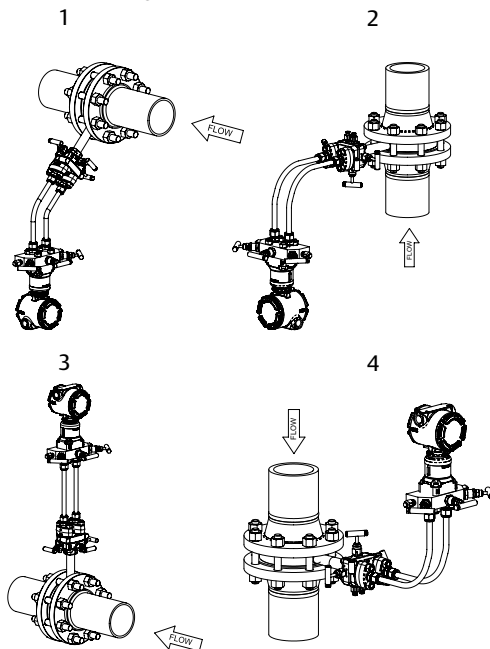
1. The DP transmitter for a liquid application must be mounted above the piping centerline (e.g., for a buried pipe).
2. The DP transmitter for a gas application must be mounted below the pipe centerline (e.g., an overhead pipe rack).

**Figure 10.28: Annubar flow meters for remote mounting.**



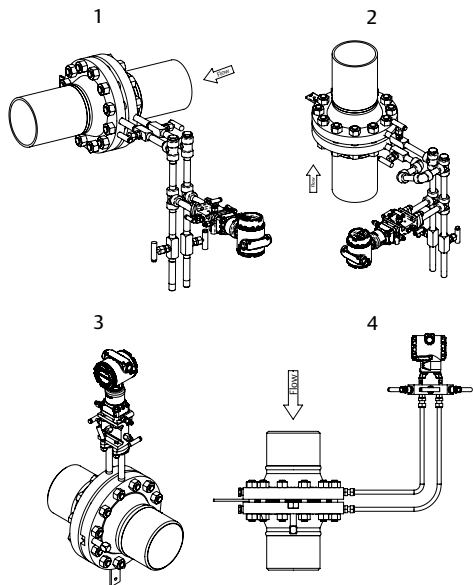
1. Horizontal Pipe – Liquid or Steam Applications
2. Vertical Pipe – Liquid or Steam Applications
3. Horizontal Pipe – Gas Applications
4. Vertical Pipe – Gas Applications

**Figure 10.29: Rosemount 405 platform flow meters for remote mounting.**



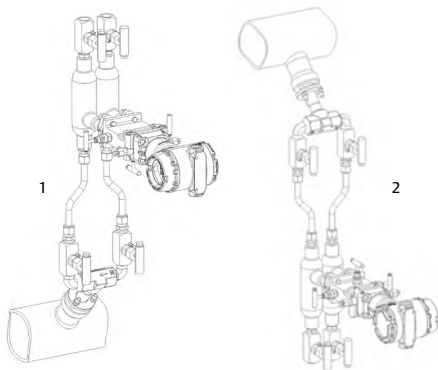
1. Horizontal Pipe – Liquid or Steam Applications
2. Vertical Pipe – Liquid or Steam Applications
3. Horizontal Pipe – Gas Applications
4. Vertical Pipe – Gas Applications

**Figure 10.30: Orifice plate flow meters for remote mounting.**



1. Horizontal Pipe – Liquid or Steam Applications
2. Vertical Pipe – Liquid or Steam Applications
3. Horizontal Pipe – Gas Applications
4. Vertical Pipe – Gas Applications

**Figure 10.31: Special impulse piping arrangements.**



1. DP Transmitter Mounted Above Piping – Liquid Applications
2. DP Transmitter Mounted Below Piping – Gas Applications

When designing a remote-mounted impulse piping arrangement, it is best to use tubing and compression fittings rather than pipe. Tubing can be bent to configuration, which will eliminate many threaded connections and reduce potential leaks. Running the impulse tubing near heat sources or where it could be damaged by activity in the area should be avoided.

## 10.7 Flow Meter Installation

Once the location and orientation of the flow meter have been determined, care must be taken to properly align the flow meter during installation.

### 10.7.1 Flow Direction Arrow

Emerson’s Rosemount flow meters and primary elements have a flow direction arrow stamped or cast into the bodies and the inlet side noted on orifice plates. See [Figure 10.32](#). Ensure that the flow arrow is pointing in the same direction as the process flow.

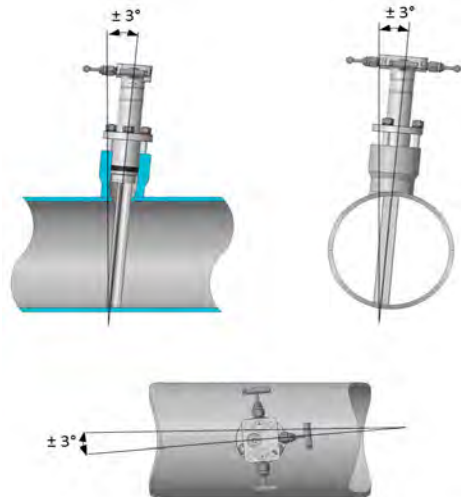
**Figure 10.32: A flow direction arrow is stamped or cast into Rosemount flow meters and primary elements.**



## 10.7.2 Annubar Primary Element Alignment

For more detailed instructions on how to install Annubar primary elements, refer to the Quick Start Guides or reference manuals. The Quick Start Guide should be reviewed prior to beginning the installation to ensure all necessary tools and parts are present. Annubar flow meters utilize a coupling that is welded to the pipe wall. In addition to providing the seal to the pipe and structure to attach the meter, it must be aligned to the pipe axis so that the sensor is aligned to the fluid flow. [Figure 10.33](#) shows the three axes of alignment and the tolerance in degrees. It is important to follow installation guidelines while welding. Pipe insulation must be removed at the mounting location and the pipe wall cleaned in preparation for welding. For Annubar primary elements that include opposite side support, the hardware needs to be mounted so that the weld couplings are aligned on opposite pipe walls. This can be done using a paper tape to mark the pipe OD, then mark a point equidistant between the end marks. The mounting holes are drilled first, and then the couplings are centered over the holes. The Annubar primary element can be mounted to the couplings as a fixture to facilitate this process, but it must be removed after tacking the couplings to the pipe to prevent damage from the weld process.

**Figure 10.33: Annubar primary element alignment tolerances.**



Annubar primary elements are built to the customer's pipe specifications so that the sensing slots and holes will be fully inside the pipe ID. It is necessary for the Annubar primary element to be installed fully across the flow profile. For Pak-Lok, Flange-Lok, and Flo-Tap assemblies, the tip of the Annubar flow meter must be pinned firmly against the opposite sidewall of the pipe for proper support.

## 10.7.3 Orifice Plate Alignment

It is important to center primary elements properly. Primary elements that are not properly centered in the flow profile can suffer accuracy degradation.

### 10.7.3.1 Rosemount 405 Compact Platform

For the Rosemount 405A, 405C, and 405P compact meter platform, alignment rings center the meter wafer in the pipe during installation and are made for each nominal pipe size. Each ring includes labeled features for three or more flange pressure ratings. [Figure 10.34](#) shows the alignment ring positioned on the flange studs to center the Rosemount 405C meter wafer. The locations of the features for Class 150, 300, and 600 flanges are stenciled on the alignment ring.

Similar alignment rings are available for DIN and JIS style flanges. Once the meter is oriented in the pipe for the application and is centered in the pipe, the bolting studs are tightened and the nuts torqued to specification.

**Figure 10.34: Rosemount 405 platform alignment ring.**



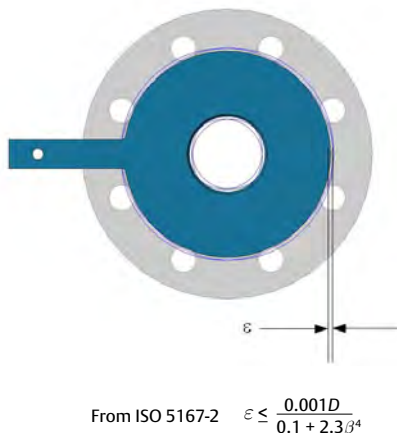
### 10.7.3.2 Rosemount 1195 Integral Orifice Primary Element

The Rosemount 1195 design includes fasteners that ensure alignment of the plate. For the Rosemount 3051SFP Integral Orifice Flow Meter, all components are assembled to the meter. The meter should be oriented in the pipe depending on the fluid type. The flange bolting can restrict orientation if the mating flanges are already installed in the system piping.

### 10.7.3.3 Rosemount 1495 and 1595

The alignment for traditional orifice plates in the pipe is dictated by standards. For ISO 5167-2, the alignment requirement is shown in [Figure 10.35](#). Orifice plates are made for the flange size and rating they are installed with, and the plate OD will fit inside the stud bolts. Although the flange stud bolts help with centering the plate, they are smaller in diameter than the flange bolt holes. This requires the plate to be centered before tightening the bolts. Although less sensitive to alignment, due to the multiple bores, the requirements for the Rosemount 1595 are the same.

**Figure 10.35: Orifice plate alignment.**



## 10.7.4 Transmitter Installation

Transmitters should be installed for easy access, personnel safety, and to facilitate calibration verification and commissioning of the system. Common things to consider when mounting a pressure transmitter include:

- Mount the device close to the process using minimal impulse tubing.
- Mount the device in an environment that has minimal ambient temperature change.
- Install the device to minimize vibration, shock, mechanical damage, and solar exposure.
- Mount the device to prevent or limit external contact with corrosive materials.
- Use thread-sealing tape or thread compound on housing conduit ports to provide a water/dust tight seal for the housing. Plug any unused openings.
- If panel or pipe mounting, place in a location that is protected, and provide enough distance around the device for access to the wiring ports.
- If mounting the transmitter outdoors, near motors, or an electrical switch gear, use a transient terminal block and properly ground the device.



In addition to properly mounting the device, it is important to follow proper wiring practices as discussed in [Section 10.3.9](#).

## 10.8 Special Installation Considerations

### 10.8.1 Hot Tapping

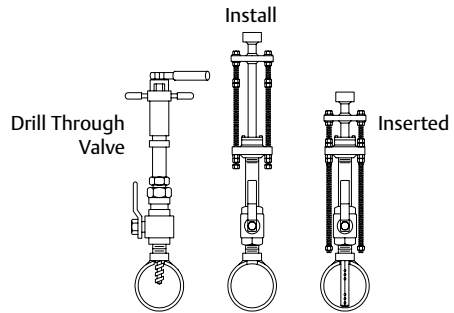
Hot tapping is a method to install a primary flow element into a process pipe without shutting the process down. Emerson offers an Annubar flow meter with this mounting style called Flo-Tap. There are several types of Flo-Tap models that allow the insertion/retraction of the Annubar sensor through a valve while under pressure. This type of Annubar flow meter can also be installed during a plant shutdown without the need for the hot tapping process. A true hot tap is done while the pipe is under pressure using a special machine called a hot tapping machine. There are several manufacturers of hot tapping machines, and there are vendors who specialize in performing the hot tapping process. [Figure 10.36](#) shows a typical hot tapping machine.

**Figure 10.36:** A simple hand-operated hot tapping machine.



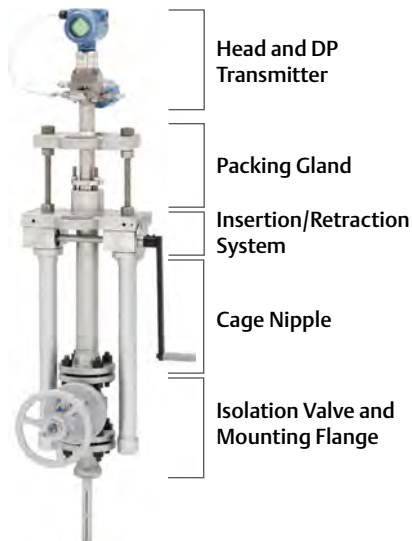
A hole is made in the pipe using the hot tap drilling machine and isolation valve. After the hole is made, the isolation valve is closed, the drill removed, and the Annubar flow meter installed without process interruption. This mounting method is necessary when the process fluid either cannot be stopped or the process itself is too costly to shut down. [Figure 10.37](#) shows this operation. Refer to the Quick Start Guide for more details.

**Figure 10.37:** Flo-Tap installation.

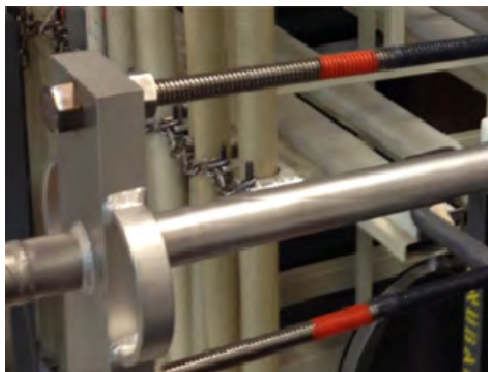


The Rosemount Annubar Flo-Tap assembly includes the packing gland, cage nipple, isolation valve, and mounting hardware. Flo-Taps for large pipes can be quite heavy and support of the assembly may be needed. There are two types of insertion/retraction systems: manual and gear-drive. The gear-drive system is shown in [Figure 10.38](#). This system turns the moving nuts simultaneously, making the process fast and simple. However, the large mechanical advantage of the worm-drive, which is a component of the gear drive, will cause severe damage to the sensor if the Flo-Tap is over inserted. To prevent this, an orange stripe is placed on the threaded rods to indicate when the sensor will be close to the opposite pipe wall. [Figure 10.39](#) shows this feature. Dimensions are also given with each Flo-Tap so that a full insertion can be made without damaging the unit. As mentioned in [Section 10.2.2.2](#), until the Annubar sensor reaches and is firmly set to the opposite pipe wall, the maximum allowed flow rate is greatly reduced. It may be necessary to reduce the pipe flow at the measuring location during the insertion/retraction process.

**Figure 10.38: Annubar Flo-Tap flow meter components.**



**Figure 10.39: The orange stripes on Flo-Tap hardware indicate the correct depth of the Flo-Tap Annubar primary element.**

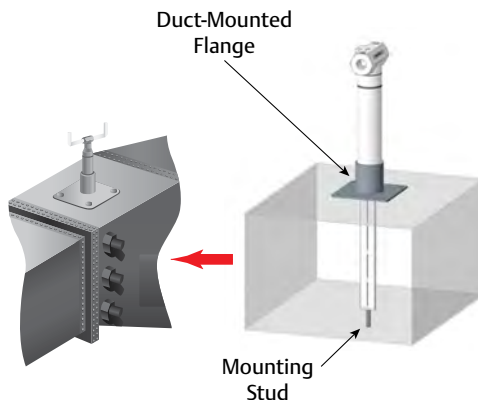


## 10.8.2 Duct Mount

This mounting style allows for the installation of an Annubar flow meter in a thin-walled duct for air flow measurement. [Figure 10.40](#) shows a primary element mounted in a square, thin-walled duct using a special flange. The flange can be curved for circular ducts and is rated for low pressure. Four holes in the corners of the flange allow for mounting screws. The opposite

end of the primary element includes a threaded-stud that is passed through a small hole in the opposite wall.

**Figure 10.40: Primary element mounting in a thin-walled duct.**



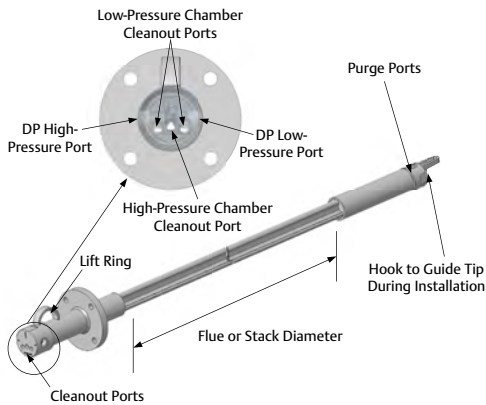
Ducts can be quite irregular in shape and typically do not include much straight run, so locating an Annubar flow meter in a duct can be a challenge. As a rule-of-thumb, Annubar flow meters are located on the longer dimension of a rectangular duct. In some instances, multiple Annubar flow meters are used across the shorter duct dimension and are arranged to provide the maximum coverage of the measuring plane.

## 10.8.3 Stack/Flue Gas

The Stack Annubar Flow Meter is installed in flues or stacks to measure emission flow. [Figure 10.41](#) shows the Stack Annubar Flow Meter. A Stack flow meter utilizes the Rosemount 485 size 3 sensor, and it is designed with purging and cleanout ports to minimize plugging even in highly particulate-laden emissions. [Figure 10.42](#) shows a typical stack application for this type of primary element. Cleanout ports permit rodding out of the three chambers in a Rosemount 485, and purge ports allow the injection of air or other gas through the Annubar primary element to reduce the buildup of solids. Stack Annubar primary elements are available for large stacks [i.e., greater than 96 in. (2.4 m) is possible].

They can be manufactured as a stub element up to 60 in. (1.5 m) long to be inserted into very large stacks to measure a portion of the flow profile. These are generally a third of the stack diameter. *Figures 10.43* and *10.44* show a Stack primary element after removal and years of service. Despite the appearance of a dirty and fouled flow element, this primary element was still functioning. Periodic cleaning should be a part of the maintenance requirements for this type of service. The Stack primary element allows repeatable performance where flow measurements are historically difficult.

**Figure 10.41: Components of the Stack Annubar primary element.**



**Figure 10.42: Stack Annubar Primary Element mounted about halfway up a large emissions stack.**



**Figure 10.43: Stack primary element removed from a stack to be cleaned. Even with significant buildup of solids on the Annubar Averaging Pitot Tube, the sensing ports remained clear.**



**Figure 10.44:** Close up of the solids buildup on the base of the Stack Annubar sensor exterior. Required maintenance is needed to clean the sensor periodically.



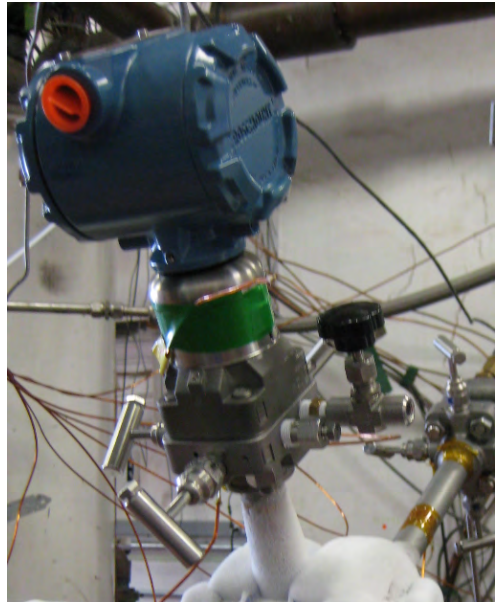
### 10.8.4 Cryogenic Fluids

Cryogenic fluids warrant special installation guidelines, but as a general rule, the transmitter should be remote mounted above the pipe to prevent contact with the cold liquid. As with steam, the DP transmitter must be protected, in this case from extremely low temperatures. In some cases, it is possible to use a direct mount flow meter for cryogenic applications. [Figure 10.45](#) shows a Rosemount 405C Compact Conditioning Orifice Plate with a Rosemount 3051S DP transmitter on liquid nitrogen service. Liquid nitrogen has one of the lowest boiling points for cryogenic liquids at 77 K (-321 °F, -196 °C). During tests, this flow meter gave results within  $\pm 0.5\%$  of the measured mass flow, and the transmitter DP cell never dropped below 70 °F (15 °C). The reason this is possible is because of the small internal tubes used in the Rosemount 405 platform products, which prevent liquid from rising far into the tubes. This keeps nitrogen

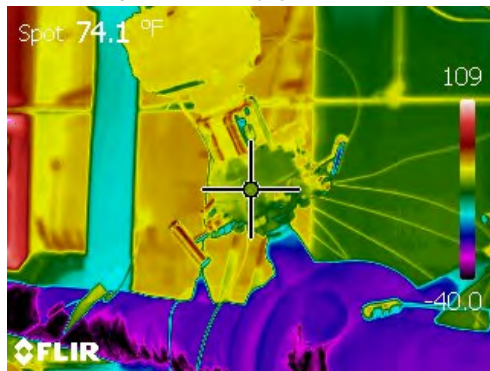
gas in the areas above, which prevents the DP transmitter from seeing low temperatures.

[Figure 10.46](#) shows an infrared image of the same flow meter that is shown in [Figure 10.45](#). The pipe exterior is at -40 °F (-40 °C) while the transmitter cell is at 74 °F (23 °C). The other reason this application was possible is because the room was warm and the top of the primary element uninsulated. An outside installation in a cold climate would need other provisions, such as a heated enclosure, to provide an ambient temperature of 40 °F (4.4 °C) or greater to obtain this same result.

**Figure 10.45:** Direct mount DP flow meter on a cryogenic application.



**Figure 10.46: Infrared image of a Rosemount 3051SFC direct mount flow meter on cryogenic service.**



For remote mounting of the DP transmitter or flow meter, ¼-in. O.D. (6 mm) tubing is recommended and the transmitter mounted should be at least 12 in. (300 mm) above the primary element. As with other high temperature applications, the equalizer valve should never be opened without isolating the meter from the process during flowing conditions to prevent the temperature from dropping below the minimum.

If the piping is insulated, the neck of the flow meter and transmitter should remain uninsulated to maintain a proper operating temperature.

To ensure a gas barrier between the transmitter and cryogenic liquid, the flow meter should be mounted within 45° of the top of the pipe for horizontal flow. This is between the 10 o'clock and 2 o'clock positions. Vertical flow orientations are not recommended unless the transmitter is remotely mounted.

## 10.8.5 Steam Applications

This section summarizes the required installation for steam flow applications. The large range of pressures and temperatures for steam piping require several different products, materials, and methods of installation to ensure a successful application. [Table 10.3](#) shows the maximum permitted temperatures for the available products and materials for steam service.

**Table 10.3: Maximum temperatures for steam service.**

Primary Element Material	Rosemount Product Models	Direct Mount <sup>1</sup> °F (°C)	Remote Mount °F (°C)
316 Stainless Steel (316SS)	485, 585	650 (343)	850 (454)
	405A, 405C, 405P	450 (232)	850 (454)
	1195	450 (232)	850 (454)
316SS/Alloy C-276	1495, 1595	–	800/1200 <sup>2</sup> (427/649)
C-276	485, 585	650 (343)	1250 (677)
Alloy 800H	585	–	1500 (816)

<sup>1</sup>For temperatures above 400 °F (204 °C), high-temperature packing must be used, and a high-temperature, 5-valve manifold included with the system.

<sup>2</sup>For the Rosemount 1495 and 1595, the temperature is limited to a maximum of 800 °F (426 °C) for DP values ≥ 400 inH<sub>2</sub>O (99 kPa). For DP values < 400 inH<sub>2</sub>O (99 kPa), a maximum temperature of 1200 °F (649 °C) is possible.

### 10.8.5.1 Direct Mounting for Steam Service

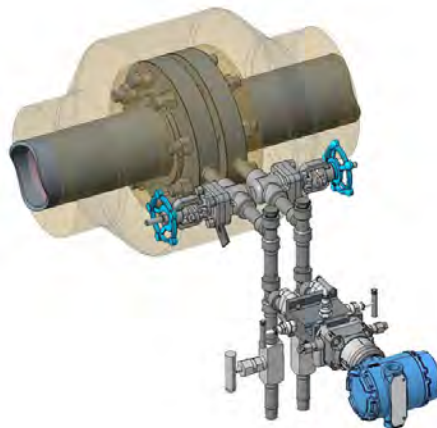
While using the direct mount system for a steam application is possible, the ambient heat around the close-mounted transmitter must not be exposed to temperatures above 185 °F (85 °C) to avoid damaging the transmitter. This is possible when the transmitter is mounted below the horizontal-pipe centerline or below the DP taps on a vertical pipe installation with proper pipe insulation and ambient conditions. Mounting the direct mount flow meter to the top section of the pipe is not a recommended best practice due to the dependence on the ambient temperature condition. The temperature can vary greatly based on the season for an outdoor installation and the available air circulation at the location of the meter in an indoor installation. If a local DP transmitter interface is needed, it is possible to use a remote display, which can be mounted in a convenient location.

### 10.8.5.2 Installation Requirements for High Temperature Steam Service

High steam temperatures require a remote-mounted flow meter. In addition to the model of flow element and the material used, a DP meter system for high temperature and pressure steam must be properly installed. It is safest to use a wet-leg system to ensure water or condensate remains in the DP transmitter and manifold. The vapor portion of the impulse piping should be exposed to the ambient air and not insulated. The length of the vapor piping should be 1 ft (0.31 m) for every 100 °F (38 °C) the steam is above the saturated temperature. There must also be sufficient water-filled impulse tubing to ensure the DP transmitter is not subjected to process temperatures above 185 °F (85 °C).

It is common for the impulse piping system to be of all-welded construction. Gate valves, rated to the maximum conditions, are used as root or primary shutoff valves. The shutoff valves and DP sensing lines should be routed from the primary element DP taps on a horizontal plane outwards to a set of tee fittings using the branch port of the tee fitting. The DP sensing lines should be uninsulated and the distance to the tee fittings adequate to dissipate heat from the steam to at least 50 °F (10 °C) below the saturation temperature for the expected line pressure. This horizontal section should have an ID of at least ½ in. (15 mm) to allow for excess condensate forming to have a free path back to the primary element DP taps. The tee fittings are to be installed with one port directed upwards to serve as a fill/vent port and the other port to route sensing lines downwards towards the transmitter. *Figure 10.47* shows a typical steam application installation for a traditional orifice plate.

*Figure 10.47: A traditional orifice plate system on horizontal steam pipe.*



If there is adequate heat dissipation over the horizontal section of the sensing lines, then there will be stable wet legs in the vertical section from the transmitter ports and up to the middle of each tee fitting.

For both direct and remote mount installations, other factors may affect the success of the installation. These factors include ambient temperature, insulation, and type and size of impulse piping and connections. These conditions must be considered as they could affect the process temperature limits or potentially cause failures in the steam installation.

### 10.8.6 Flow Meter Installations for High Temperature and Pressure

The Rosemount 585 Severe Service Annubar Primary Element, shown in *Figures 10.48* and *10.49*, is designed for high pressure and temperature applications. The gun-drilled solid bar stock material makes it much stronger than conventionally manufactured elements, enabling it to withstand extreme conditions. The Rosemount 585 can be used for pressure ratings up to 2500 Class and temperatures up to 1250 °F (677 °C).

**Figure 10.48:** The Rosemount Severe Service Annubar Primary Element, which is designed for severe service.



**Figure 10.49:** The Rosemount 585M Main Steam Line Annubar Primary Element with opposite side support.



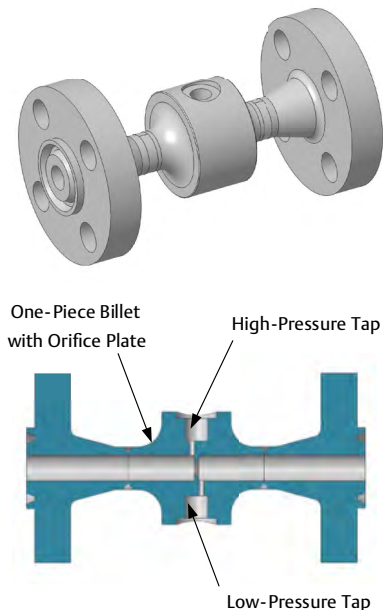
The Rosemount 585M Main Steam Line Annubar Primary Element, shown in [Figure 10.48](#), takes this design one step further, enabling it to withstand the high pressures and velocities on main steam lines to turbines.

## 10.8.7 Orifice Plate Installations for High Pressure and Temperature

Custom engineered-to-order solutions are available when process conditions fall outside the range that can be accommodated with standard products.

[Figure 10.50](#) shows a special all-welded integral orifice primary element that is machined out of a single billet and includes an all-welded construction. It is suitable for extreme pressure and temperature applications in small line sizes. The orifice plate is machined into the billet, eliminating gaskets and bolts around the plate. Special materials are available.

**Figure 10.50:** Special all-welded integral orifice primary element.

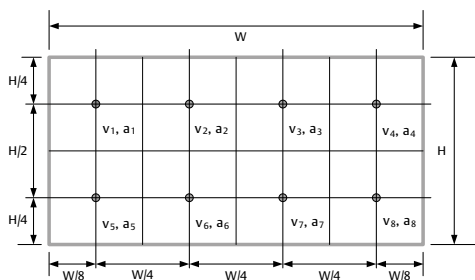


These are examples of what can be provided from Emerson to accommodate difficult applications. For more information, contact your local Emerson representative.

## 10.9 In-Situ Calibration Using Pitot Traverse

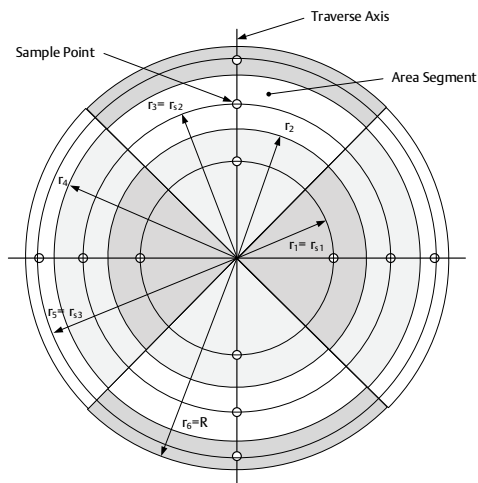
Large ducts and stacks present a unique challenge to flow metering. The size precludes obtaining a formal calibration from a flow laboratory, and the installation is typically in a location that is close to upstream disturbance-producing fittings. For these reasons, if a calibration is required, it is done on-site, or in-situ. The most practical method for doing this is by sampling the stack or duct flow using a pitot tube and integrating the samples to obtain the flow rate. The first task is to determine where the pitot traverse will be done. Ideally, the traverse plane is upstream within one equivalent diameter from the flow element. The sampling is done by breaking the measurement plane into small sections or segments. *Figure 10.51* shows this sampling grid for a rectangular duct with height ( $H$ ) and width ( $W$ ) dimensions. The area is broken into eight equal area segments, and the sample location is in the geometric center of each segment. To provide a pitot traverse, the duct can be entered either at two axes on the  $H$  side or at four axes on the  $W$  side. The side selected depends on accessibility and the overall size of the duct. An important consideration is that the length of the pitot tube must be sufficient to cross the entire duct. Access to the duct requires clearance to insert the pitot tube. Once decided, couplings are mounted to the duct wall for the pitot tube.

**Figure 10.51:** Traverse-point locations for a rectangular cross-section broken into eight segments.



For a circular section, the sample points are determined using the centroid of equal areas method (see *Chapter 7*). *Figure 10.52* shows a circular section broken into equal-area segments for a 2-axis traverse and 3 points-per-radius. Access ports and couplings are fastened to the duct or stack wall at the axis points.

**Figure 10.52:** Traverse point locations for a circular cross-section.

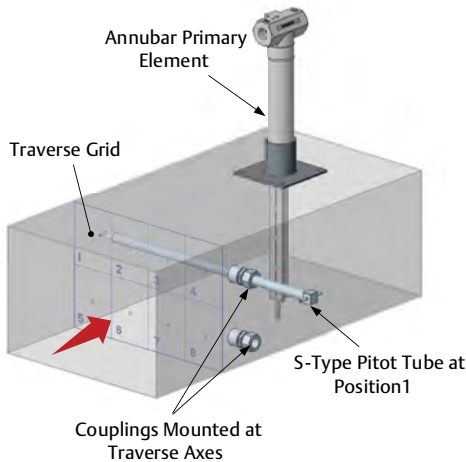


It is customary to conduct a pitot traverse to establish the actual flow rate at a maximum, minimum, and normal system operation or load. Note: It is important that the flow rate is held steady during the pitot traverse process. The pitot tube usually has a temperature sensor that reads the fluid temperature and a manometer or pressure gauge is used to read the pressure.



Figure 10.53 shows a duct, pitot tube, and Annubar primary element set up to do a calibration using an 8-point traverse with two axes (instrumentation is not shown). In this figure, the sample-point grid is imposed on the measuring plane and the pitot tube is positioned at Axis 1, Point 1. The data points for the pitot DP, fluid temperature, pressure, and Annubar DP are taken for each sample location and logged for each flow rate. This is usually done using a spreadsheet program. The gas density is calculated, and then the velocity of the gas is determined at each sample point.

Figure 10.53: An in-situ calibration using a pitot traverse.



For a sampling grid using equal-area segments, the actual volume flow rate is:

$$Q_A = \bar{V}A, \text{ ft}^3/\text{sec} (\text{m}^3/\text{sec})$$

Where:

- $\bar{V}$  Average velocity for the number of sample points, ft/sec (m/sec),  $\bar{V} = \sum_{i=1}^N v_i / N$
- $v_i$  Velocity at the  $i$ th sample point, ft/sec (m/sec)
- $N$  Total number of sample points
- $A$  Internal area of the pipe or duct,  $\text{ft}^2 (\text{m}^2)$

For a cross section where the areas are not equal:

$$Q_A = \sum_{i=1}^N v_i a_i$$

Where:

- $a_i$  Area representing the  $i$ th sample point,  $\text{ft}^2 (\text{m}^2)$

For an Annubar flow meter, the calibration will determine the flow coefficient at each tested flow rate. For installations close to disturbances, such as elbows, reductions, or dampers, the flow coefficient may not be constant across the range of flow. The flow coefficient,  $K$ , is calculated using the volumetric flow equation from Chapter 3:

$$Q_v = NK D_{eq}^2 \sqrt{\frac{\Delta P}{\rho}}$$

Where:

- $N$  Value 0.099702 for ft<sup>3</sup>/sec (3.5124E-05 for m<sup>3</sup>/sec) – see Chapter 3 for other values of  $N$  for selected units of flow rate
- $D_{eq}$  Equivalent round duct or pipe diameter, in. (mm) – this is the diameter of a circular duct, or the value:  $D_{eq} = \sqrt{\frac{4HW}{\pi}}$  for a rectangular duct. Note: If the values of  $H$  and  $W$  are in ft (m), the diameter must be converted to in. (mm)
- $\Delta P$  Average differential pressure from the Annubar, inH<sub>2</sub>O (kPa), during the pitot traverse for the flow rate measured
- $\rho$  Average gas or air density, lb<sub>m</sub>/ft<sup>3</sup> (kg/m<sup>3</sup>) during the pitot traverse for the flow rate measured

Rearranging this equation to solve for  $K$ :

$$K = \frac{Q_A}{N D_{eq}^2 \sqrt{\frac{\Delta P}{\rho}}}$$

The values obtained for the flow coefficient are programmed into the flow meter or distributed control system (DCS) used to calculate the corrected stack or duct flow rate.

## 10.10 Commissioning

The process of preparing a DP flow meter for operation is called commissioning. This section gives a brief explanation of commissioning a DP flow meter. See the appropriate reference manual for a more thorough explanation.

Before commissioning a DP flow meter, the meter system must be leak checked. See [Figures 10.54](#) and [10.55](#). This is done by closing the primary or root valves (i.e., PH and PL) to isolate the meter from the pipe and pressurizing the system. This is usually done with compressed air. The test pressure should be greater than the maximum operating pressure of the system, but not higher than the maximum design pressure.

The DP transmitter is equalized during this process to prevent an over pressure across the DP cell. In some cases, a soap solution can be used to look for telltale bubbles indicating a leak. All leaks must be repaired before proceeding. A leak in the system can induce a differential pressure that is many times greater than the primary element DP.

Commissioning includes filling the impulse piping with the flowing fluid, or seal fluid if appropriate, while monitoring the DP signal and ensuring that the DP zero is within specification (i.e., the transmitter mA output signal is between 3.98 and 4.02 mA). Once this is done, the flow meter is put into operation.

[Figure 10.54](#) shows a traditional DP flow meter configuration for a steam application, and [Figure 10.55](#) shows a direct mount configuration for a typical gas flow meter. For a gas, this is not required. For liquid or steam applications, the air in the impulse piping system must be replaced with the flowing liquid (or water), which is called bleeding. There will always be pockets of air in the system that require extra diligence to remove. Drain and vent valves (i.e., DVH and DVL) are used to help do this. Always use appropriate safety procedures when bleeding a flow meter.

**Figure 10.54: Traditional DP flow meter valves for a 3-valve DP manifold.**

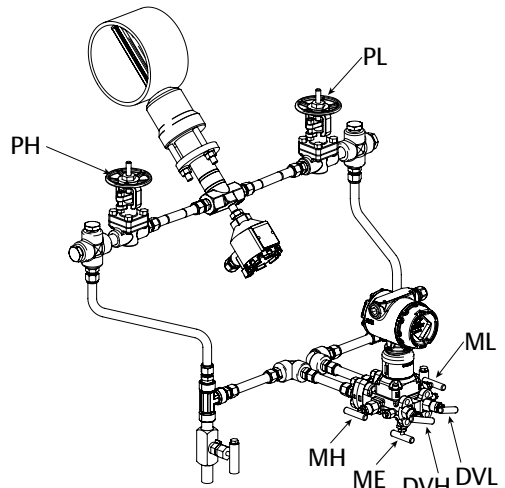
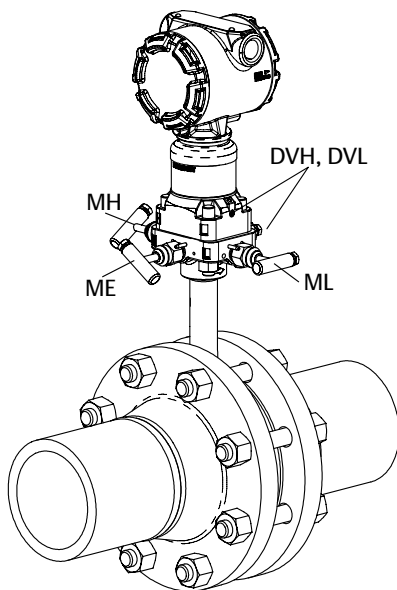


Figure 10.55: Direct mount DP flow meter system valves.



One method that will ensure that the air has been removed is called dry zero-wet zero. After the system is leak checked and isolated from the process using valves MH and ML while the equalizer valve(s) (i.e., ME) are opened, the DP transmitter zero is set. This is also called a zero trim. After bleeding the system, if there is still air lodged in the piping, a DP signal will be indicated, which could be positive or negative. When the system is successfully bled with all air removed, the zero DP signal obtained earlier will return.

Bleed a liquid or condensate steam flow meter system by opening the isolating valves (i.e., MH and ML) and the primary valve (i.e., PH and PL) if included, then opening the drain and vent valves to release the air in the system. This procedure must be done carefully, as process fluid will escape from the system. Check the DP meter wet zero after closing the drain/vent valves. This process may need repeating before the dry zero returns.

For a steam vapor system, the isolation valves are not opened. The system is filled with water by removing the plugs from the crosses or tees,

and water is introduced to fill the system. When no more air is apparent, close the drain and vent valves and check the value of the DP zero as previously explained. Replace the plugs using an appropriate pipe compound for the steam system.

Once the system is leak checked and bled, the equalizer valves (i.e., ME) are closed and the isolation valves (i.e., MH, ML) opened. Check the output to confirm that the value read (i.e., either the DP or the flow rate) is within the parameters of the application.

Note: 5-valve manifolds have two equalizer valves and a vent valve, whereas 3-valve manifolds have no vent and only one equalizer valve. See [Chapter 7](#) for an explanation of DP manifolds.

## 10.10.1 DP Flow Meter Commissioning Procedure

The following is a DP flow meter procedure that can be used while commissioning a DP flow meter. A transmitter digital communication device and/or a milliammeter is needed. See the appropriate reference manual for more information.

- 1. If needed, disconnect the system from any control loop** — For a new installation, this shouldn't be required; however, it is important to ensure that the system is not connected to any active control system.
- 2. Check the devices installed** — Confirm that the transmitter and primary element products installed are the correct units for the application. Tags on each component can be checked against the specification sheets for the application. Flow element design pipe size and the DP transmitter value at full scale should also be checked.
- 3. Isolate the DP or flow transmitter** — If open, close the isolation or root valves (i.e., PH and PL) on the primary element or at the DP transmitter using the manifold isolating valves (i.e., MH and ML).

- 4. Open the equalizer valve(s)** — Open the equalizer valve(s) (i.e., ME) to provide a zero DP on the transmitter. There may be more than one equalizer valve.
- 5. Connect to the device** — To monitor the DP during commissioning, a portable communicator is used. For a DP transmitter, it is also possible to use a milliammeter connected to the test terminals, which will indicate the equivalent current signal (4 to 20 mA for 0 to full scale DP). Note: Digital communication requires the correct voltage drop at the communicator to function. Flow meters may require a HART® communicator to monitor the DP signal. See the reference manual for the device or refer to [Chapter 8](#).
- 6. Trim the DP zero** — Using a field communicator, trim the DP zero. See the transmitter reference manual for a complete explanation of zero trim.
- 7. Bleed the system** — For a liquid or steam system, bleed the system of air using the instructions here or in the reference manual. Monitor the DP transmitter output. If properly bled, the signal value at zero seen in step 6 will return.
- 8. Put the system into operation** — Close the equalizer valve(s) (i.e., EH) (and vent valve for a 5-valve manifold), and make sure all appropriate plugs for the system have been reinstalled. Open the manifold isolating valves (i.e., MH and ML), and if included, the primary valves (i.e., PH and PL).
- 9. Check system operation** — Check the value of the DP signal against the flow system calculation sheet to see if it is within the expected operating range. For a flow meter, check the displayed flow rate. Steam applications will take some time to come to thermal equilibrium, and it may be necessary to check the DP zero again.

### 10.11 Installation Checklist

The following installation checklist reiterates much of the material of this chapter. Due to the large application range for DP flow measurement, all possible types of applications are not covered here, but the basics for a proper installation are the same.

1. For a gas flow meter, is the DP transmitter mounted above process connections to prevent accumulation of liquids? If not, is there a drain system to collect liquids?
2. For a liquid flow meter, is the transmitter mounted below the process connections to prevent trapping gases? If not, is there a vent system to collect gases?
3. For a steam flow meter, is the primary element installed below the process connection? Is the maximum steam temperature below the maximum for the type of meter, material, and installation?
4. For a steam wet leg system with saturated steam, is the vapor portion of the impulse system properly insulated? For a superheated steam system, is there sufficient uninsulated vapor tubing to reduce the temperature to saturation?
5. For remote mounted systems, do the impulse lines have a continuous slope with no bends or smooth long radius bends and are run together?
6. Does the system have vent and drain valves at the appropriate locations?
7. Does the system include a manifold with an equalization valve?
8. Has the DP impulse piping system been leak checked?
9. Do the DP transmitter and impulse lines need freeze protection?
10. If heat tracing is used, is it placed properly to keep the system from freezing? Is there sufficient insulation installed?

11. Has the liquid or stream system been properly bled of air?
12. For dirty flow applications, is there a method for purging the primary element?

Problems with installations can occur. Isolating and correcting problems requires methodical checking and verifying each component and using other knowledge of the control system. These and other topics are covered in [Chapter 11](#).

### 10.12 Additional Information

For more information on Emerson's Rosemount DP flow products, consult the PDSs, Quick Start Guides, and reference manuals on [Emerson.com/DPFlow](#), or consult your local Emerson representative.





## Calibration, Maintenance, and Troubleshooting

	<b>Topic</b>	<b>Page</b>
11.1	Introduction	248
11.2	Safety First	248
11.3	Calibration	248
11.4	Maintenance	257
11.5	Troubleshooting	267
11.6	DP Flow Meter Operation Checklist	267
11.7	Additional Information	269

# 11 Calibration, Maintenance, and Troubleshooting

## 11.1 Introduction

This chapter completes the information in this guide by presenting what is needed to ensure and maintain a dependable and accurate differential pressure (DP) flow meter measurement. This information should be used in conjunction with the appropriate reference manual.

## 11.2 Safety First

The processes involved with calibration, maintenance, and troubleshooting can expose personnel to dangerous conditions. Before any work is started, the following precautions should be taken. These are general precautions and may not include all safety-related issues. Ensure that required local safety procedures are followed.

### 11.2.1 Know the Process Fluid and Conditions

Exposure to the process may occur when working on a flow meter. Personnel need to know the type of fluid in the pipeline and the pressure and temperature at which it is operating. A current Safety Data Sheet (SDS) should be available and reviewed before beginning work. If the primary element is to be removed, the pipeline must be shut down and safely bled of pressure. All components should be cool to the touch before proceeding.

### 11.2.2 Wear Proper Personal Protection Equipment (PPE)

All personnel in the immediate area must wear required PPE during servicing of the flow meter. Safety glasses, gloves, hearing protection, steel-toed shoes, hard hat, and other equipment may be needed. Check local plant requirements. Some plants require that personnel attend a safety seminar before starting work.

### 11.2.3 Understand the Proper Procedures before Starting Work

Review the reference manuals for the necessary work procedures. The proper order of opening/closing valves for pressure check, bleeding, commissioning, and/or other operations should be understood before proceeding.

### 11.2.4 Bleed or Vent Fluids

The process fluid may need to be bled from the instrument lines (for a liquid) or vented during some maintenance procedures (for a gas). Exposure of personnel to the process fluid may present a hazard and may require special procedures or protocols. Check with local plant operations management before releasing any process fluid(s). Primary elements removed from the pipe may need to be decontaminated before work is done.

## 11.3 Calibration

Calibration is the process of comparing the output of an instrument to that of a reference (i.e., known accurate) instrument given the same input. When an instrument is calibrated, the proper output is confirmed by the technician over the range of measurement. Before any adjustments are made, the output is recorded. This is called the as-found calibration. If any adjustments are made, the output is checked again and recorded. This is the as-left calibration. If no adjustments are needed, the as-found values are used.

One benefit of a DP flow meter is that the two major components, which are the primary element and the DP transmitter, can be calibrated or verified independently. A flow system can then be assembled into a complete flow meter with an uncertainty based on the two component calibrations. This capability allows the primary elements and the DP transmitters to be stocked and assembled into calibrated flow meter systems when needed.



## 11.3.1 Calibration and Verification

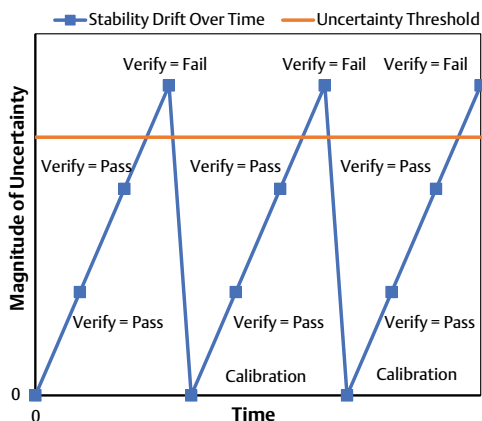
Initial calibration and required maintenance of DP flow instrumentation is necessary to maintain accuracy and reduce instrument error over time. Instrument error can occur as the result of various factors, including sensor drift, environmental changes, electrical supply variations, addition of components to the output loop, primary element wear, or contamination, process changes, and more. Calibration is the process that minimizes these instrument errors. A calibration is performed to ensure that a flow meter is operating within acceptable accuracy requirements. This may require trimming or adjusting the sensor if the transmitter is found to be out of specification, inspecting and cleaning the primary element, and leak checking the impulse piping system.

DP primary element calibration must be done in a flow laboratory. In rare cases, an in-situ calibration can be performed, but it may be more costly and difficult to perform. After a calibration is performed, a certificate or report will be issued that confirms the performance of the specific unit. If a primary element has not been calibrated, the performance can be stated using available sufficient statistical evidence for the design type and required tolerances. See [Section 11.3.2](#) for more information.

Verification is similar to calibration except that no trims or adjustments are performed on a flow meter. It is simply a method that verifies the flow meter output is within the stated accuracy range. It is recommended to perform a verification before any calibration, allowing users to efficiently confirm performance without inducing potential errors involved with a full calibration. [Figure 11.1](#) demonstrates how verifications should be done first, and only if the unit fails verification should a calibration be performed. Calibration and verification should be performed with precision calibration equipment that has a traceable uncertainty 3-5 times better than the instrument being calibrated. Inadequate calibration equipment, improper use of equipment, or improper calibration procedures

can result in the introduction of systematic error to the flow meter measurement. For the DP primary element, geometry verification will ensure that the device is operating within specifications. An example of this is verifying the bore diameter on an orifice plate and confirming that it still has a sharp edge. Verification allows confirmation of the device's accuracy without risking the introduction of error.

**Figure 11.1: The relationship between calibration and verification.**



## 11.3.2 Uncalibrated and Calibrated Performance

There are two types of DP primary element performance categories: uncalibrated and calibrated.

An uncalibrated performance must be determined from a sufficient sample of statistical data for calibrated primary elements of the same design type and size, and manufactured to an appropriate standard. Provided the same process is used to manufacture new devices of the same type, the statistical calibration value can be used for the new device. The uncertainty for an uncalibrated flow element will always be greater than for a calibrated one.

A calibrated DP primary element includes a calibration certificate from a traceable flow calibration laboratory. A calibration is performed

by installing the primary element in the pipe size it was designed for. A fluid flows through the pipe at a known flow rate while the output of the primary element is measured. The discharge coefficient (for an area DP meter) and flow coefficient (for an averaging pitot tube) are determined over a range of flow rates. These values are included in a calibration report and used when the flow meter is configured.

### 11.3.3 Flow Meter Calibration Systems

A flow laboratory is required to calibrate a flow meter. To ensure that a calibration is valid, flow laboratories are also calibrated and traceable. Traceable means that the determination of the flow rate utilizes measures that are traceable back to a national authority for weights and measures. In the United States, the authority is the National Institute of Standards and Technology (NIST). In other countries, there is usually a government-directed department of weights and measures.

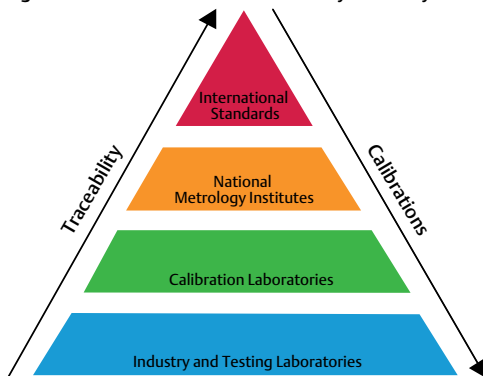
#### 11.3.3.1 Gravimetric Calibration Systems

The most direct method to obtain a traceable flow rate is by using a gravimetric flow calibration system that measures a mass of fluid collected over a given time. While there are volumetric systems that collect a given volume, they are less accurate and more difficult to use than gravimetric systems.

In a gravimetric system, the components that measure the mass and time are calibrated using test articles (i.e., reference weights and time standards), which are usually stored on-site. These components are calibrated by a local authority (i.e., usually a state weights and measures department). The local authority has their equipment calibrated by the national weights and measures authority. Thus, the measuring system at the flow laboratory is said to have traceability or a pedigree that goes back to the national authority, and in most cases, the international authority. [Figure 11.2](#) shows the traceability hierarchy. Each successive calibration creates a slightly higher uncertainty.

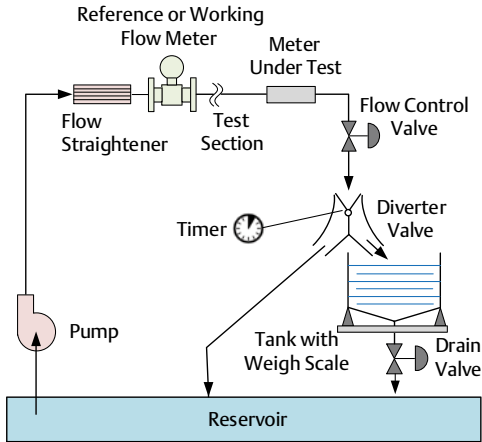
For a flow laboratory to claim traceability, all measured values used in the calibration should be supported by a certificate showing the calibration and the pedigree.

**Figure 11.2: Calibrations and traceability hierarchy.**



For a liquid (usually water) flow lab, the liquid can be collected in a gravimetric tank that is a part of a weigh scale. A gas is more complicated as the gas must remain isolated from the air, so a closed system is required. Gravimetric gas tanks can be pressurized with gas and weighed before and after the gas is discharged through the system. The weigh scale system must be of a special design to determine a very small change in mass for a relatively heavy tank. [Figure 11.3](#) shows a schematic of a typical liquid gravimetric flow calibration system. For a true flow rate system, a diverter valve is used to start and stop the collection of the liquid in the gravimetric tank, and the elapsed time is measured by using a switch on the diverter valve that starts and stops the timer.

**Figure 11.3: Gravimetric flow calibration system.**



**Table 11.1: Gravimetric flow meter calibration measurements.**

Parameter	Measuring Device
Mass	Weigh Scale
Time	Timer Counter
Flow Rate	Working Standard Flow Meter
Temperature	Resistance Temperature Detector (RTD) or Thermocouple
Pressure	Pressure Transmitter (for Gases)
DP	DP Transmitter

The calibrated uncertainties for these instruments are combined using the flow or discharge coefficient equation to produce the overall calibration uncertainty. The final uncertainty number should be one-third to one-fifth of the stated uncertainty for the flow meter. For example, if the flow laboratory claims a flow meter calibrated uncertainty of  $\pm 0.5\%$ , the combined uncertainty for the flow lab should be  $\pm 0.16\%$  or lower.

### 11.3.3.2 Reference or Working Standard Meter Systems

A gravimetric calibration is the most accurate, but it can take longer and be more expensive to run a calibration. For this reason, flow meters are sometimes used as a calibrated flow reference, also called a working standard meter. This is done by using the gravimetric system to calibrate the reference flow meter(s). This calibration must have an uncertainty calculated, and it is shown as the reference flow rate uncertainty on the flow meter calibration report. Turbine, magnetic, or Coriolis flow meters are typically used as working standard flow meters. To reduce the uncertainty, data from successive calibrations of the working standards are collected or pooled to determine the meter uncertainty.

### 11.3.3.3 Uncertainty for the Laboratory and the Test Meter

As stated in [Section 11.3.3.1](#), every instrument used to obtain a calibration of the flow meter must be calibrated and traceable. For a DP flow meter, the measurements made to produce a calibration are shown in [Table 11.1](#).

### 11.3.4 Reynolds Number Operating Range

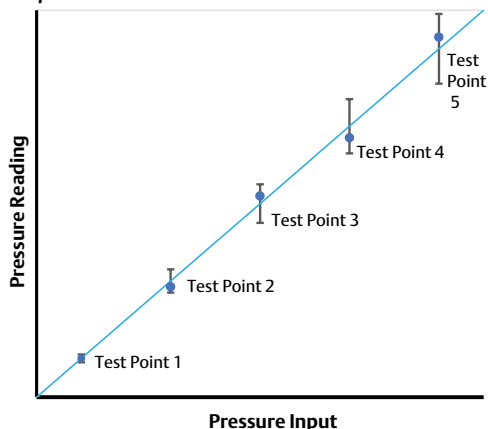
For a DP flow primary element, a calibration should represent the meter operation independent of fluid type and flow units. This is done by showing the calibration results at the equivalent Reynolds number for each flow rate. Ideally, the calibration of a DP primary element will show a Reynolds number range that matches the application flow rate range. This is not always possible though as the flow rates tested are limited by the flow lab capability. In some cases, a flow meter may be supplied for a gas application, but only a liquid flow lab is available. The Reynolds number range of a typical gas flow is 10-100 times higher than for an equivalent liquid flow due to the much lower value for the viscosity. A liquid calibration for a gas flow meter application is only possible if the DP flow primary element design has shown Reynolds-number independence, which means that there is little or no change in the flow or discharge coefficient for liquids and gases.

## 11.3.5 Calibration and Verification of the DP Transmitter

Due to increased stability, repeatability, and accuracy, today's transmitters require less frequent calibrations. Since calibration changes factory-programmed parameters in the transmitter, any time a calibration is performed, there is a risk of introducing error to the device from inaccurate reference equipment. For this reason, a verification should be performed before proceeding with calibration. Verification and calibration of DP transmitters can be performed in controlled environments, such as a worktop bench or in the field. It is important to note that if calibration equipment is large and sensitive to the environment, it can be difficult to move the equipment while maintaining reference uncertainty.

A verification often consists of multiple test points that are usually spaced evenly within the transmitter's calibrated range. *Figure 11.4* shows an example of a 5-point transmitter verification. The error bars show the required range that each test point needs to stay within in order to pass verification. In this example, the transmitter must maintain a DP measurement uncertainty of  $\pm 0.5\%$ . As each point is measured, the as-found values in the verification table (*Table 11.2*) are filled out. Each value passed verification because the as-found values are in between the acceptable range. In this case, the transmitter does not need to be calibrated.

*Figure 11.4: An example of a 5-point transmitter verification.*



Calibration is only needed if the transmitter verification test fails. Emerson's family of Rosemount™ transmitters are calibrated using a 2-point sensor calibration, which consists of a lower sensor trim and an upper sensor trim. Due to the linearity of Emerson's Rosemount pressure transmitters, only a 2-point calibration is needed.

It is important to understand and follow calibration and operation instructions from the reference manual as well as site-specific safety documentation. For example, if the manifold valves are not properly manipulated, incomplete equalization of high- and low-pressure ports will cause calibration and performance errors.

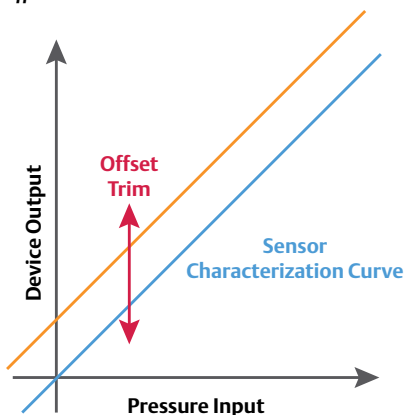
*Table 11.2: An example of a verification/calibration report.*

Input (%)	Desired Input (inH <sub>2</sub> O)	Desired Output (inH <sub>2</sub> O)	Minimum Acceptable (inH <sub>2</sub> O)	As-Found (inH <sub>2</sub> O)	As-Left (inH <sub>2</sub> O)	Maximum Acceptable (inH <sub>2</sub> O)
0	0	0	-0.75	0.05	0.05	0.75
25	37.5	37.5	37.31	37.48	37.48	37.69
50	75	75	74.63	75.06	75.06	75.38
75	112.5	112.5	111.94	112.42	112.42	113.06
100	150	150	149.25	150.02	150.02	150.75

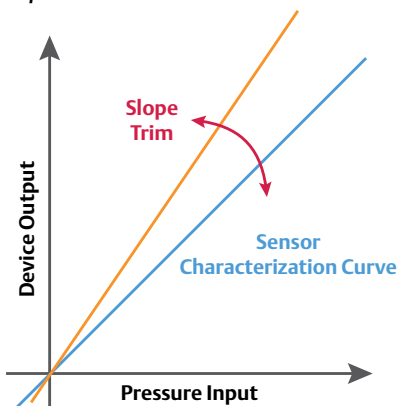
## 11.3.5.1 Sensor Trim

A sensor trim is an adjustment that changes the slope and offset of the sensor characterization curve. The lower sensor trim, or offset trim, corrects the offset as shown in [Figure 11.5](#). The upper sensor trim, or slope trim, corrects the slope of the characterization curve as shown in [Figure 11.6](#).

**Figure 11.5:** The sensor characterization curve during an offset trim.



**Figure 11.6:** The sensor characterization curve during a slope trim.

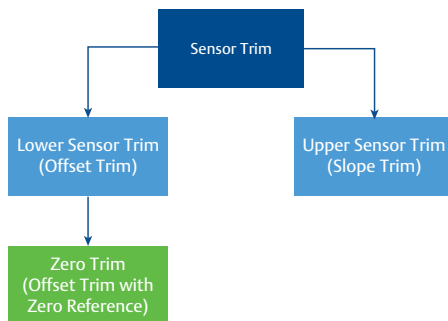


## 11.3.5.2 Zero Trim

A zero trim is a single-point offset adjustment. A zero trim is a lower sensor trim (i.e., offset trim) that uses a known reference of zero DP as shown in [Figure 11.5](#). It is useful for compensating for mounting position effects once a transmitter

has been installed in its final mounting position. For example, if a DP transmitter is installed at a 45-degree angle and vented to atmosphere, the transmitter will register a DP value. In actuality, there is no DP present because atmospheric pressure is equal on either side of the DP cell. A zero trim will remove the offset error that is present due to the transmitter mounting by using a known physical state of reference, which in this case, is zero DP. [Figure 11.7](#) summarizes the relationship between each type of sensor trim.

**Figure 11.7:** The relationship between each type of sensor trim.



## 11.3.5.3 Analog Trim

An analog trim adjusts the transmitter's analog output to match the plant standard of the control loop. Specifically, it allows manipulation of the transmitter's current output at the 4 and 20 mA points by adjusting the digital to analog signal conversion.

## 11.3.5.4 Bench and In-Situ Calibration

DP transmitters can be calibrated on a bench or in-situ. Benchtop calibration takes place in a controlled environment where tools and calibration equipment are already present, and the transmitter is not installed in an active process. In-situ calibration is performed when calibration equipment is brought to a transmitter in its field installation. Generally, bench calibration is a more cost-effective method and can be easier. There is less preparation for bench calibration since there is extra work associated with a transmitter in the field, such as isolating it

from the process and bleeding any process fluid. However, certain situations may still require in-situ calibration.

### 11.3.6 The DP Transmitter Calibration Equipment and Standards

Emerson recommends using a reference pressure device that is at least 3-5 times more accurate than the transmitter for calibrations. Finding accurate reference pressure equipment can be difficult and expensive.

It is important to verify the accuracy of the equipment that is used, especially if performing a calibration in the field. A recent calibration record should be available indicating when the unit was last verified or calibrated to determine if the instrument is within specification and is traceable.

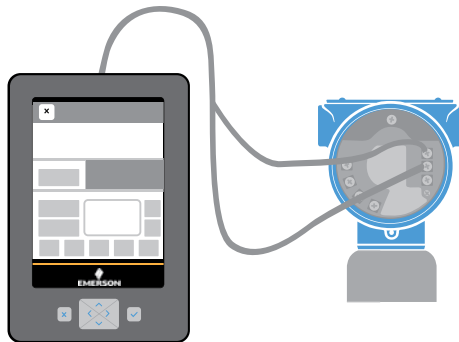
Emerson's factory calibration process uses NIST-traceable reference equipment that is 5-10 times more accurate than the transmitter. The initial calibration is stored in the electronics of the transmitter, and the original factory calibration can be restored if needed. The stored factory calibration is a way to mitigate degraded performance. For example, a possible source of degraded performance could be due to carrying out a calibration with inaccurate reference equipment. Since Emerson employs such accurate equipment for initial factory calibration, the only recommended adjustment after shipment is a zero trim to account for mounting and installation effects. A calibration consisting of both a zero trim and sensor trim should only be performed following a failed verification test.

### 11.3.7 Calibration Procedure

Due to potential variations in certain operations, such as manifold valve sequence and sensor trims, calibration should always be performed by following manufacturer-recommended procedures. However, in general, this is how to calibrate a transmitter:

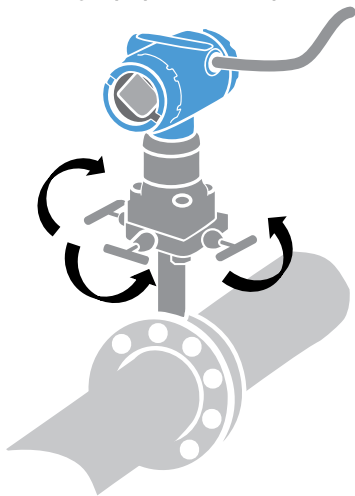
1. Check calibration equipment and confirm the proper procedure for calibration. If doing a calibration on-site, carefully transport the equipment to the transmitter.
2. Connect the communication device to the transmitter. See [Figure 11.8](#).

**Figure 11.8:** A handheld communicator connected to a transmitter.



3. Set the manifold valves according to calibration procedures found in the reference manual. See [Figure 11.9](#).
4. Connect the reference pressure source to the transmitter. See [Figure 11.10](#).
5. Check the accuracy of the transmitter at multiple points (i.e., a verification).
6. If the transmitter is within an acceptable accuracy, it would be considered in specification, and a calibration would not need to be performed. If the transmitter is outside of the acceptable specification, then a full calibration is needed.
7. Perform a lower sensor trim. This is often called a zero trim.
8. Perform an upper sensor trim.
9. Return the transmitter to operation.

**Figure 11.9:** The manifold valves should be manipulated according to proper calibration procedures.



**Figure 11.10:** A reference pressure source connected to a transmitter.



More information about the calibration procedure and proper manifold operation can be found in the reference manuals.

### 11.3.8 Calibration Frequency

Every pressure transmitter requires verification and calibration that often follows a schedule dictated by a variety of factors. For example, the criticality of a process measurement, regulation by a governing authority, or specifications from the manufacturer will impact the determined

verification and calibration schedules. Using the manufacturer's recommendations will lay the groundwork for how often a device may need to be verified and, if needed, calibrated. If the required performance is known, it can be used in conjunction with manufacturer-published specifications to calculate the frequency of the verification and subsequent calibration.

The calculation frequency is determined by:

1. The total probable error, which is comprised of reference accuracy, ambient temperature effect, and line pressure effect. See [Chapter 7](#) for more information.
2. The stability specifications of the transmitter, which can be determined from the product data sheet (PDS). In general, stability is specified as a percentage of span over a given length of time.
3. The required performance value, which is defined by the user of the device.

These three components are then used to calculate the calibration frequency by using the following equation:

$$CF = \frac{(RP - TPE)}{S_{month}}$$

$$CF = \frac{(0.2\% - 0.105\%)}{0.00167\%} = 57 \text{ months}$$

Where:

*CF* Calibration frequency

*RP* Required performance, which is 0.2% of span

*TPE* Total probable error, which is 0.105% of span

*S<sub>month</sub>* Stability per month, which is 0.00167% of span

Companies will often develop standard verification/calibration intervals (e.g., quarterly, yearly, etc.). These intervals can be more frequent if a measurement is crucial to the

process and requires regular maintenance. If high performance and accuracy is required or the unit is used in a safety instrumented system (SIS), shorter calibration cycles are more likely to be mandated.

### 11.3.9 Pressure Transmitter Calibration

Many DP flow installations incorporate static pressure measurement. For static pressure sensors, the calibration and verification procedure is similar to the DP sensor. One unique thing to keep in mind when calibrating static pressure sensors is the difference between gage and absolute sensors. When baselining a gage sensor, a zero trim should be used. However, when baselining an absolute pressure transmitter, a lower sensor trim should be used. The lower sensor trim should reference the atmospheric pressure where the transmitter is installed, or absolute pressure imitated by using a vacuum pump to bring the pressure near zero.

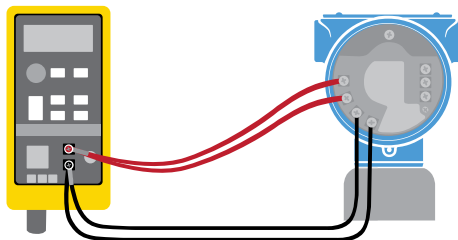
### 11.3.10 Temperature Transmitter Calibration

In DP flow applications, it is important to understand how temperature transmitters are calibrated because temperature measurement is used to compensate for changes in various fluid properties and thermal expansion of the system components. Calibration of temperature transmitters, or the temperature portion of multivariable transmitters, involves the process of calibrating the transmitter resistance temperature detector (RTD) input.

The calibration of a temperature transmitter begins by simulating an RTD with an accurate resistance simulator. Two examples of resistance simulators are shown in [Figures 11.11](#) and [11.12](#). The RTD simulator is then used to verify the temperature output from the transmitter compared to the known resistance-based temperature of the simulator. There are tabulated values of temperature that correspond to a measured resistance depending on the RTD type; in most cases this a Pt-100. If the transmitter is found to be out of specification, then the sensor values are trimmed using the

recommended calibration procedures found in the reference manuals.

**Figure 11.11: Sample RTD simulation set up.**



**Figure 11.12: Resistance decade box.**



In addition to the transmitter electronics, the RTD itself can be characterized. This can be done with a dry well or immersion bath that will cover the required temperature range. The bath is set to a known temperature, and the RTD resistance output is measured at various test points and compared to the expected resistance values for that temperature. The test points are fit to the expected outputs with a set of mathematical equations, producing a set of coefficients that characterize that specific sensor. An example of such coefficients is the Callendar-Van Dusen (CVD) constants. When the specific CVD constants are known for an RTD, they can be programmed in the transmitter to increase the accuracy of the temperature measurement. Use the RTD manufacturer's recommendations when characterizing the physical RTD sensor.



For more information on temperature measurement and calibration, refer to *The Engineer's Guide to Industrial Temperature Measurement* on [Emerson.com](http://Emerson.com).

### 11.3.11 Calibrating the Multivariable Transmitter

Multivariable transmitters can include differential pressure, static pressure, and temperature sensors within one device. The calibration of multivariable transmitters is done by individually calibrating each one using similar procedures as single variable devices. In essence, calibration of a multivariable transmitter is the same as calibrating three individual devices through a single connection. All calibrations can be performed by hooking up to the same location on the transmitter terminal block and utilizing a field communicator and accurate reference equipment to perform the various sensor trims.

## 11.4 Maintenance

All DP flow primary elements should be inspected periodically. The DP flow primary element contains no moving parts, so maintenance only involves cleaning and checking the dimensions and pressure cavities. Knowledge of the DP flow meter application is required to perform maintenance safely. All personnel should adhere to the manufacturers' and plant's recommended safety procedures, and wear appropriate PPE while performing any maintenance activity.

### 11.4.1 Annubar Primary Element Maintenance

In most cases, Rosemount Annubar™ primary elements need very little maintenance. The frequency of inspection is dictated by the type of service and level of potential contamination. Liquid or gas flows with entrained solid particulates should be checked every few months. Clean fluid applications should be checked yearly.

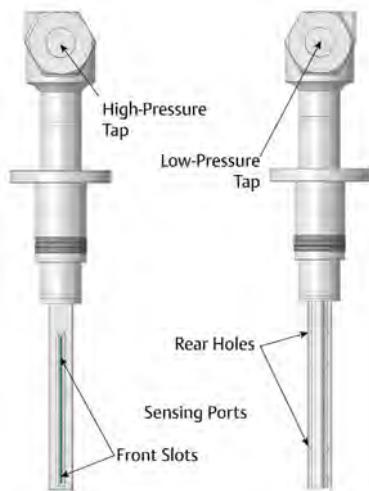
#### 11.4.1.1 Inspection

Proper maintenance requires that the Annubar primary element be removed from the pipe. This requires shutting down the pipe (i.e., isolating and depressurizing) and waiting until the pipe is cool to the touch. If there is an Annubar Flo-Tap primary element, it can be removed without depressurizing the pipe using the proper sequence of steps for retraction as outlined in the reference manual. Disconnect the impulse tubing as close to the Annubar primary element as is practical. The Annubar sensor needs to be removed carefully to avoid damaging the edges and surfaces of the sensor. Large or Flo-Tap units may require mechanical assistance such as a crane. If the service includes caustic material, it must be decontaminated safely before inspecting. Once the sensor is removed and decontaminated, place it on a workbench.

#### 11.4.1.2 Cleaning

The surfaces and sensing ports of the Annubar primary element should be clear and free of deposits or foreign material. Use compressed air to verify that the chambers and sensing ports are not blocked. [Figure 11.13](#) shows an Annubar primary element and the port connections to check. Introduce compressed air to the tap fittings, and note the air coming out of the sensor ports. If there is no or very little air flow coming out of the sensing ports, investigate what may be causing the blockage. Some models can be cleared using a wire or tubing brush. Soaking in solvent may be required, but whatever is used should not damage the primary element material.

Figure 11.13: Annubar primary element taps and ports.



Clean the Annubar sensor surfaces using an appropriate solvent and a non-metallic bristle brush. An Annubar primary element with the optional grit-blasted surface should have a rough surface similar to the image shown in [Figure 11.14](#).

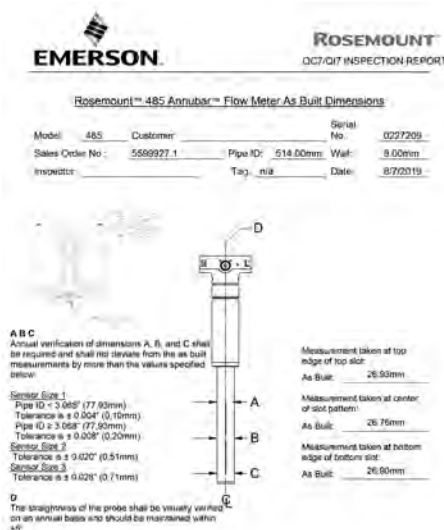
Figure 11.14: Grit-blasted surface of a Rosemount 485 Annubar primary element.



### 11.4.1.3 Annubar Primary Element Geometry Verification

Annubar primary element inspection includes verifying the critical geometry of the sensor. If the product was ordered with an inspection report, the latest measurements can be compared to the values in the report to determine how much wear may have occurred. [Figure 11.15](#) shows the critical dimensions and an example of values for the models and sensor sizes.

Figure 11.15: Annubar flow meter inspection report.



### 11.4.1.4 Leak-Checking the Annubar Primary Element

The Annubar primary element has a high-pressure chamber and a low-pressure chamber. These chambers must not leak from one to the other. This can be checked using a gasket and metal strip that can be clamped over the front slots. The high-pressure tap can then be connected to an air source and pressurized to check for any leaks at the low-pressure tap. The pressure does not need to be very high—only to the level of the measured DP. For example, a DP of 200 inH<sub>2</sub>O would be tested to 7.2 psi (49.7 kPa). For information regarding impulse piping inspection for remote mount installations, see [Section 11.4.2.4](#).

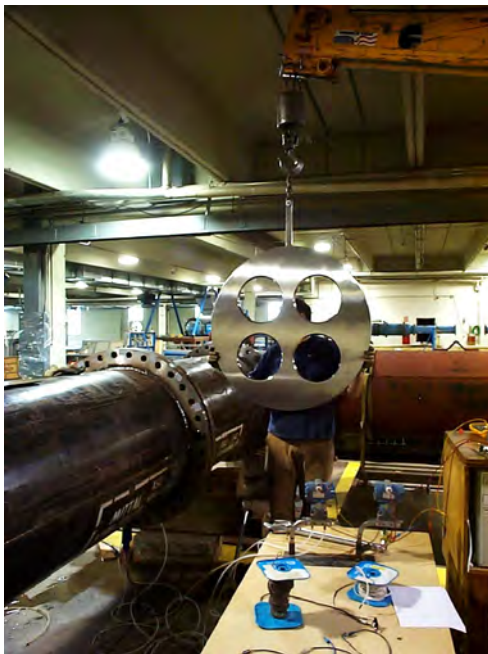
### 11.4.2 Area Meter Primary Maintenance

Area DP flow meters use the area of the upstream and throat sections to generate the DP signal. These areas must be free of obstructions and wall contamination. In addition, orifice plates have an edge on the bore that is designed specifically for the flow meter. Sharp-edge orifice bores require that the edges meet the specifications in the standards for proper operation.

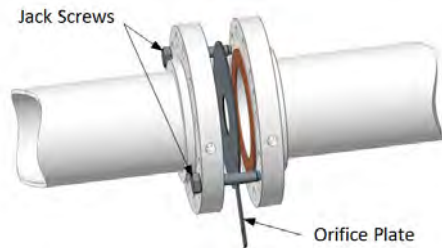
## 11.4.2.1 Inspection

Proper inspection of an area meter requires that the meter and the surrounding pipe be inspected. This is especially true for orifice plates, as the pipe represents a portion of the meter. The pipeline should be isolated and depressurized. If the service was at elevated temperatures, the system should be cool to the touch before meter inspection. Removal of a large area meter may require mechanical assistance, such as a crane. See [Figure 11.16](#). This is especially true for flanged-spool meters such as a Venturi, wedge, primary element, or cone meter. Orifice plates can be removed by removing the stud bolts and opening the flanges. Orifice flanges have jack screws on them for this purpose. [Figure 11.17](#) shows removal of a traditional orifice plate. Orifice holder fittings have provisions for removing the carrier and orifice plate. See [Figure 11.18](#).

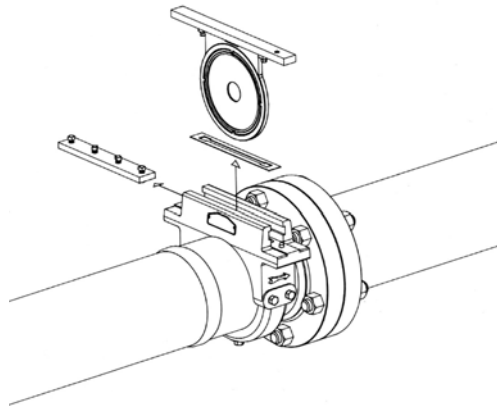
**Figure 11.16:** Installing a large Conditioning Orifice Plate using a crane.



**Figure 11.17:** Removing an orifice plate using jack screws to spread the flanges.



**Figure 11.18:** Removing an orifice plate from an orifice fitting.



The inspection frequency of an area meter depends on the severity of service. Liquid or gas flows with entrained solid particulates should be checked every few months. Clean fluid applications should be checked yearly.

Inspect the area meter internal bores for deposits of solids and for any damage. Inspect the orifice plate surfaces and bore edges. While the plate surfaces may be discolored, there should be no collection of solids or erosion visible on the surface.

## 11.4.2.2 Cleaning

If there are deposits on the area meter, they should be removed using an appropriate solvent. A wire brush should not be used unless it is of a material that will not scratch the surface. The sharp edge of the orifice plate should never be touched by any material that could damage the edge.

### 11.4.2.3 Orifice Bore Condition and Measurement

Sharp-edge orifice bores should be checked for sharpness by using a strong light beam aimed toward the edge. While rotating the plate, no light should be reflected from the edge. Nicks and other damage should be easy to spot. If the orifice edge is not damaged, it is unlikely that the bore needs to be measured.

### 11.4.2.4 Impulse-Piping Inspection and Leak Checking

The impulse-piping system is used for remote-mounted DP transmitters that convey the two pressures between the primary and secondary elements. The system, which is typically customized for each installation, is made up of valves, tubing or piping, and fittings.

The following steps should be taken to inspect and ensure that the system is functioning:

1. Check the piping and fittings for corrosion. Deposits seen around the threaded fittings can be an indication of a leak. Inspect the impulse piping for any visible damage, bends, or cracks.
2. The primary shut-off valves should shut off the process completely. If they are leaking after shut off, they should be repaired or replaced.
3. If heat tracing is installed, ensure that the heat tracing is operational and covers the impulse tubing sufficiently.
4. Some DP flow meters include access ports to rod-out the impulse tubing and taps. If blow-down valves are installed in the impulse piping system, they can be used to ensure that there is no blockage of the impulse piping. Isolate the DP transmitter using the DP manifold, and with the primary valves open, open the blow-down valves one at a time. Using caution, collect the process fluid in an appropriate container.

5. After the system is inspected and cleaned, pressurize to check for leaks:
  - a. Bleed the process fluid. With the primary valves closed and the manifold isolation valves and equalizer valve(s) open, connect a source of compressed air to either the high- or low-pressure side.
  - b. Pressurize the impulse piping. The pressure should be higher than the process pressure, but not greater than the rated system pressure. Use leak-check solution or soapy water to check for leaks.
  - c. Repair any leaks.
  - d. Remove the compressed air and recommission the system.

### 11.4.3 DP Transmitter Maintenance

Even if a transmitter is functioning properly, it is common to inspect the unit for deterioration resulting from normal exposure to process and environmental conditions. Ensuring that flow meter components are in the correct place can increase the lifespan of the transmitter significantly. For example:

- Transmitter covers should be threaded far enough that there is metal-on-metal contact between the housing and the cover.
- To prevent galling of the cover threads, make sure a non-galling lubricant is applied to the threads.
- Conduit entry points should be inspected to ensure adequate tightness in order to prevent water ingress.
- Inspect the transmitter body for any signs of corrosion or physical damage.
- Inspect the wiring terminals for signs of corrosion, and make sure that the terminal screws are sufficiently tightened for secure contact of wires.
- Ensure all installation bolts are torqued to specification.

- If the transmitter has an LCD screen, see if it is displaying an error message and if it is reporting reasonable measurement values. If an error message is present, check the error message description in the reference manual.

### 11.4.4 Commissioning the DP Flow Meter

Commissioning a flow meter consists of verifying the installation and then putting the system into service. A DP flow meter should be first leak-checked and then bled of air if the application is liquid. See [Section 11.4.2.4](#) for more information. Monitor the DP transmitter signal before and after bleeding. See [Section 10.10](#) for a more complete description of commissioning.

When a transmitter is taken out of service for maintenance, recommissioning the transmitter is necessary to ensure proper operation. The basic steps to recommission a transmitter include:

1. If needed, disconnect the system from any control loop.
2. Verify that the correct devices are installed.
3. Isolate the DP or flow transmitter.
4. Open the equalizer valve(s).
5. Connect to the device and verify configuration.
6. Trim the DP zero.
7. Bleed the system.
8. Put the system into operation.
9. Check system operation.

For more information on commissioning, see [Chapter 10](#).

## 11.5 Troubleshooting

Troubleshooting is the process of finding the root cause of why the DP flow meter is not reading properly and addressing the issue. It is possible that there is more than one reason why the meter is not functioning. It is also possible that the meter is functioning, but there is a perception that it is not. This section will explore the typical problems experienced by DP flow meters and how to fix them. Much of the troubleshooting process is done with a live (i.e., pressurized) pipe. Knowledge of the DP flow meter is required to do this safely. All personnel should adhere to the manufacturers' and plant's recommended safety procedures while performing any troubleshooting activity.

### 11.5.1.1 Verifying the DP Primary Element and Installation

Annubar primary flow elements are verified by ensuring that the correct unit is installed for the application. For most applications, each instrument has an assigned tag number. Check the tag number on the P&ID drawing for the application to see if it matches the one on the Annubar primary element tag. To check the size, locate the pipe ID value on the meter tag and compare that to the known ID for the pipe size and schedule for the application. The application pipe ID should be within -1% to +5% of the pipe ID on the Annubar primary element tag. Pipes that are smaller than 99% of the meter tag pipe ID could cause the top of the sensing slot to go inside the pipe hole or coupling, which will create a large error in reading. Finally, ensure that the Annubar primary element has been installed correctly. Check that the flow direction arrow is oriented in the direction of the pipe flow and that the unit is inserted completely. There is a dimension on the documentation that shows the pipe outside wall to the top of the head. This value should be within  $\pm 0.5$  in. (12 mm) of the measured value.

Area meters are verified in a similar way as Annubar primary elements. The unit tag numbers are checked against the plant documents to

ensure that the correct unit has been installed. The meter size (i.e., bore/beta) is then verified and checked against the configuration. Lastly, ensure that the meter is installed in the correct orientation per the flow direction arrow and is aligned to the pipe within tolerance.

### 11.5.1.2 Verifying the DP Transmitter

DP transmitters are verified in a similar fashion to primary elements. The transmitter’s tag information should be cross checked with the plant’s installation documentation to ensure that the correct unit is installed. One example of this is to confirm that the required measurement range is within the transmitter’s sensor limits. Additionally, it should be confirmed that the host system recognizes the transmitter at the correct address. Once the correct transmitter has been identified, the configuration should be verified to meet the given application and necessary plant requirements. Physical aspects of the installation, including wiring and grounding, should also be checked. Another physical verification is to

check the installation of the device to make sure that the high side of the transmitter is mounted upstream and the low side downstream.

### 11.5.2 What Is the Nature of the Problem?

If it is believed that a flow meter is not working properly, the nature of the problem and the evidence of that problem should be stated. This helps coordinate the troubleshooting process. This section is broken into four parts that address the typical problems with DP flow meters and a sequence of tasks to help uncover the problems. [Table 11.3](#) summarizes these four issues.

#### 11.5.2.1 Meter Does Not Read Flow

If the meter is not reading flow at all, there are several things that may be occurring. If there is a manifold, ensure that all valving is in the correct position to allow a DP measurement to be made. Also ensure that connections from the process to the transmitter are sealed well and that there is no process fluid escaping from piping joints.

**Table 11.3: Troubleshooting a DP flow meter: four typical symptoms.**

Symptom	Possible Causes	Possible Remedies
Meter does not read flow	<ul style="list-style-type: none"> <li>No flow in pipe</li> <li>Isolation valve(s) closed or equalizer open</li> <li>DP transmitter malfunction</li> <li>Improper configuration</li> </ul>	<ul style="list-style-type: none"> <li>Check system for adequate flow</li> <li>Put valve(s) in proper position</li> <li>Check DP transmitter</li> <li>Verify flow configuration</li> </ul>
Meter reads higher or lower than expected	<ul style="list-style-type: none"> <li>Leaks in impulse piping or drain/vent valve leaking</li> <li>Isolation or equalizer valve(s) in wrong position</li> <li>Incorrect configuration</li> </ul>	<ul style="list-style-type: none"> <li>Leak check impulse piping and transmitter</li> <li>Verify configuration of flow meter and scaling of output(s)</li> </ul>
Meter signal is very noisy	<ul style="list-style-type: none"> <li>Pulsating pipe flow</li> <li>Air in liquid impulse piping</li> <li>Condensate in gas impulse piping</li> </ul>	<ul style="list-style-type: none"> <li>Modify piping to mitigate resistance</li> <li>Bleed liquid system</li> <li>Drain or blow-down gas or steam system</li> <li>Implement damping feature on DP transmitter or flow meter</li> </ul>
Meter reading does not change with flow rate	<ul style="list-style-type: none"> <li>Clogged primary element or impulse piping</li> <li>One or both isolating valve(s) closed</li> </ul>	<ul style="list-style-type: none"> <li>Clean out impulse piping</li> <li>Check valve positions</li> </ul>

For this issue, the following procedure can be performed (see [Figure 11.19](#)):

1. Determine if flow is present in the pipe.  
Sounds, vibration, and other instruments on the pipe, such as a pressure gauge, can be used to determine that there is flow. A block valve in the piping can be partially closed to verify that there is flow since the increasing pressure drop will show as increased vibration and flow noise.
2. Check the DP transmitter signal. Monitor the DP transmitter signal by connecting a HART® communicator or milliammeter to the test terminals (see [Section 10.10](#)). To convert a 4-20 mA reading to a DP in a transmitter configured with a linear transfer function, use the following equation:

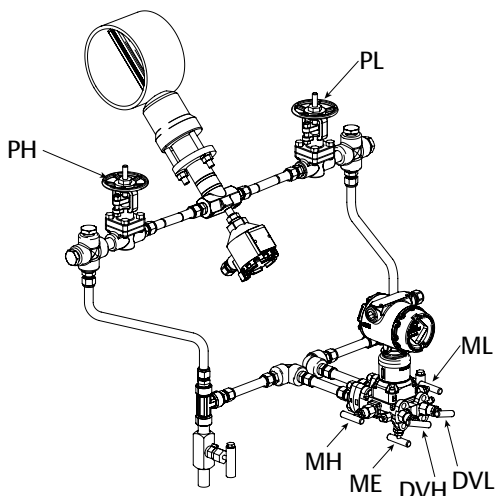
$$DP = \frac{mA - 4}{16} \times DP(fs)$$

Where:

*mA*      Milliamp analog output of transmitter

*DP(fs)*   Full scale DP for the transmitter or the DP at a 20 mA analog output

**Figure 11.19: Typical DP flow meter system and valves.**



Close the manifold isolation valves (i.e., MH and ML), and open the equalizer valve(s) (i.e., ME). Note the DP signal. It should be very close to zero or have a mA reading of 3.98 to 4.02. If not, trim the zero (see [Section 11.3.5.2](#)). Close the equalizer valve(s) first, then open the isolation valves. The reading should indicate the differential pressure on the DP primary element. If there is still little or no DP signal, and it is believed that there is flow in the piping, then the primary element and/or the impulse piping may be plugged or the DP transmitter may not be functioning.

### 11.5.2.2 Meter Reads Higher or Lower than Expected

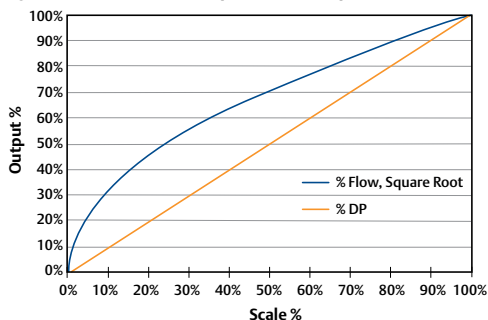
Several possible causes may lead to an abnormally high or low flow reading. One cause is a mechanical issue due to a compromised DP from a leak in the system. Large leaks will create a DP many times the full-scale DP value, and the transmitter will saturate (peg) either below zero (i.e., a leak on the high side) or above maximum (i.e., a leak on the low side). Small leaks may give an incorrect signal, but it could still be within the DP transmitter range. If this is suspected, isolate the system and perform a leak check (see [Section 11.4.2.4](#)). Once the leak check is complete, recommission the meter and set the valves to the operate position.

Another possible reason is an incorrect configuration of the flow meter. The flow equation for the primary element, type of flow, and fluid is used to set the relationship between the DP and the flow rate. Each parameter needs to be verified to be the correct value for the installation. Locate the flow calculation that was performed for the flow meter. All of the terms used in the calculation need to be verified. The primary values used in the calculation that could be causing a problem are:

1. Pipe Size — The pipe nominal size and schedule will determine the pipe ID. Assuming the wrong pipe schedule is a common problem. Verify what the correct schedule (i.e., pipe ID) is and confirm it is used in the configuration. It is a best practice to use the measured pipe ID if possible.

2. Density — The correct fluid density is needed for non-compensated flow meter systems. Confirm the fluid type and the fluid density at the flowing conditions.
3. Meter size and bore — For an orifice plate, the beta (bore) must be known within a small tolerance to give accurate flow rate values. Confirm the actual bore. For an Annubar flow meter, the correct sensor size needs to be known and used in the configuration.
4. Meter scaling — Each time an instrument analog signal is converted to a value, the correct meter scale must be used. This is true for DP, pressure, and temperature transmitters as well as the flow rate signal. The transmitter full and minimum scale values need to be known. DP transmitters are usually zero-based with no minimum scale. Pressure and temperature transmitters may have an elevated span where the process value at minimum scale (4 mA) is not zero. This is not a problem for digital-based protocols such as HART, but the scaling values used in the digital configuration should be checked. Incorrect scaling will give an incorrect flow rate.
5. Square-Root Function — DP flow meters require that a square-root function be applied to the DP transmitter's signal. This change in output function is available on even the simplest of DP transmitters. For a 0 to 100% of span DP transmitter, the linear and square-root function is shown in [Figure 11.20](#). Note that the end points for the two formats are the same (0% and 100%), and the difference is highest at low scale. More sophisticated systems use a flow computer where the square root is taken. If the flow meter system is reading very high at midscale, it is possible that the square root is being taken twice. Check that for a flow computer system, the output of the DP transmitter is set to be linear to DP.

**Figure 11.20: Linear and square-root output.**



Other reasons for an abnormal reading are insufficient straight piping upstream of the meter, misalignment, or holes in the pipe wall upstream of the meter from large pipe taps or piping take-offs. See [Chapter 10](#) for more information.

### 11.5.2.3 Meter Signal Is Noisy

A noisy signal may be due to several things. It is possible that the flow field is pulsating or resonating in the pipe. There are remedies for this, but they usually require modifying the pipe section. For a liquid application that has air in the impulse piping, changes in piping pressure will cause a jumpy DP signal. Make sure the system is properly bled of air. DP values that are less than 2 inH<sub>2</sub>O (0.5 kPa) can also be noisy due to the influence of pipe dynamics on the low signal.

The primary remedy for a noisy signal is to increase the damping of the signal. This can be done mechanically or using the damping feature in the DP transmitter or meter. Closing down the isolating valves or placing a pressure restriction in the impulse piping will help dampen a noisy signal. There are also dampeners that use non-corroding steel wool placed inside the impulse tube or piping. Care must be taken to ensure this filtering material will not become lodged in a valve or travel to the primary element.

If condensate is in the gas impulse piping, drain or blow down the system.



Digital-based DP transmitters have a digital signal-damping feature that can be used to reduce the magnitude of an oscillating signal. Use the HART communicator to access and implement this feature.

It is important to remember that damping the DP signal also increases the response time of a flow meter. Applications used for process control may not function correctly if the response is very long.

### 11.5.2.4 Meter Reading Does Not Change with the Flow Rate

A locked or non-changing signal is usually due to a clog in the impulse tubing or piping, or the valves are closed. First, check that the impulse piping is not clogged (see [Section 11.4.2.4](#)). It is also possible that the pipe or primary flow element could be clogged. Check that there is flow in the pipe (see [Section 11.5.2.1](#)). Remove the primary element and inspect for obstructions (see [Sections 11.4.1](#) and [11.4.2](#)).

Once it is confirmed that the impulse piping is not obstructed and there is flow, check that the primary and manifold isolating valves are open and the equalizer valves are closed.

It is also possible that the DP or flow transmitter is under-ranged. This can cause the output to be at the maximum value continuously.

### 11.5.2.5 Calculating the Flow Rate Manually

While a digital-based system has been a great benefit to DP flow meters, it isolates plant personnel from what is actually happening to determine the flow rate. A manual calculation can be done to get an estimate of the true flow rate. This involves finding the input values such as the primary DP, fluid density, and the primary geometry, and then doing a calculation. A simplified calculation is all that is needed, and it should be within 2-3% of the true value. This is close enough to provide a check on the flow meter displayed value. Use the following procedure to estimate the flow rate.

### 11.5.2.6 Collect Application Data

Application data is the information about the fluid, piping, and flow element needed to do the calculation. The more accurate the data, the more accurate the flow rate estimate will be. Collect the following application data:

- Differential pressure,  $\Delta P$ , in inH<sub>2</sub>O (kPa) — If the DP transmitter has a display, note the average reading. If there is only a milliamp signal, obtain the full-scale DP from the tag, and calculate the DP using the equation in [Section 11.5.2.1](#).
- Pipe inside diameter,  $D$ -in (mm) — Use the pipe chart for the size and pipe schedule. In most cases, the pipe is a schedule 40 below 12-in (300 mm) size and schedule standard for larger sizes. It is a best practice to use the measured pipe ID if possible.
- Fluid density,  $\rho$ -lb<sub>m</sub>/ft<sup>3</sup> (kg/m<sup>3</sup>) — For water at ambient temperatures, use a value of 62.3 lb<sub>m</sub>/ft<sup>3</sup> (998 kg/m<sup>3</sup>). For other temperatures, see [Figure 2.3](#). If the liquid is not water, find the density or specific gravity. For specific gravity,  $G$ , density =  $G \times 62.4$  lb<sub>m</sub>/ft<sup>3</sup> (999 kg/m<sup>3</sup>). For a gas, if the flowing density is not known, find the specific gravity, pressure, and temperature of the gas. Use the equations in [Section 2.2.7.2](#) to calculate the density. For steam, determine the temperature and pressure at the flow meter, and use the steam tables in [Chapter 6](#) to find the steam density.
- Flow or discharge coefficient — For an Annubar primary element, use the flow coefficient found in the documentation. If it is not available, use a flow coefficient of  $K=0.55$ . For an orifice plate, use the discharge coefficient found in the documentation. If it is not available, use a discharge coefficient  $C=0.60$ .
- Bore of the orifice plate — This may be stamped on the handle. If only the beta is shown, then the bore,  $d = \beta(\text{beta}) \times D$ . Note: the true bore size is critical to get an accurate calculation. If needed, spend the most time ensuring that this value is correct.

- Find the beta ( $\beta$ ) of the orifice plate, which is either stamped on the handle, or if the bore and pipe inside diameter are available,  $\beta = d/D$ .
- Calculate the velocity of approach factor:

$$E = \frac{1}{\sqrt{1 - \beta^4}}$$

### 11.5.2.7 Calculate the Flow Rate

Once the application data is collected, the flow rate is calculated. There are six flow rate equations:

1. Actual volumetric flow for area meters
2. Actual volumetric flow for Annubar flow meters
3. Mass flow rate for area meters
4. Mass flow rate for Annubar flow meters
5. Standard volume flow rate for area meters
6. Standard volume flow rate for Annubar flow meters

Shown here are four of the six examples of equations.

#### For Actual Volumetric Flow Rate

Get the value of  $N$  for the desired flow rate units from [Table 3.1](#) for U.S. Customary (USC) units and [Table 3.2](#) for SI units.

- **For an Annubar flow meter (from Chapter 3):**

$$Q_A = NKD^2 \sqrt{\frac{\Delta P}{\rho}}$$

- **For an orifice plate (from Chapter 3):**

$$Q_A = NCEd^2 \sqrt{\frac{\Delta P}{\rho}}$$

- **For Mass Flow Rate**

Get the value of  $N$  for the desired flow rate units from [Table 3.1](#) for USC units and [Table 3.2](#) for SI units.

- **For an Annubar flow meter (from Chapter 3):**

$$Q_m = NKD^2 \sqrt{\Delta P \times \rho}$$

- **For an orifice plate (from Chapter 3):**

$$Q_m = NCEd^2 \sqrt{\Delta P \times \rho}$$

#### Example 1:

Calculate the actual volumetric flow rate for an Annubar flow meter.

An Annubar flow meter is installed in a nominal 6-in. (150 mm) pipe on water flow. The following is known:

- Fluid is water at 70 °F (20 °C)
- The 6-in. (150 mm) pipe is schedule 40
- The model is a Rosemount 485, sensor size 2.  
Note: it doesn't matter if the model is a Flo-Tap, Flanged, or Pak-Lok; only the pipe size and sensor size are relevant
- The DP transmitter has a full-scale value of 150 inH<sub>2</sub>O (37.30 kPa) and a signal reading of 15.5 mA
- The desired flow rate is in gal/min

Using the volumetric flow rate equation for an Annubar flow meter:

$$Q_A = NKD^2 \sqrt{\frac{\Delta P}{\rho}}$$

Where in USC units (SI units):

- $N$  44.749 (from [Table 3.1](#))
- $K$  Annubar flow meter coefficient = 0.55
- $D$  Pipe ID = 6.065 in (154.05 mm)
- $\Delta P$  (15.5-4)/16 x 150 = 107.8 inH<sub>2</sub>O (26.81 kPa)
- $\rho$  Fluid density = 62.3 lb<sub>m</sub>/ft<sup>3</sup> (998 kg/m<sup>3</sup>) (from [Figure 2.3](#))

The calculation is:

$$Q_A = 44.749 \times 0.55 \times (6.065)^2 \times \sqrt{107.8/62.3} = 1191 \text{ gal/min}$$

### Example 2:

Calculate the volumetric flow rate for an orifice plate.

A Rosemount 405C Conditioning Orifice Plate is installed in a DN100 pipe (4-in.) on water flow. Note: DN size piping has a slightly different pipe ID than the ANSI size pipe used in the U.S. Although a pipe may be classified as DN100, it may still be an ANSI 4-in. pipe. In most cases, the Rosemount 405C will be made to the ANSI schedule 40 size, so the bore is calculated using the equivalent ANSI pipe ID.

The following is known:

- Fluid is water at 38 °C (100 °F)
- The pipe ID is 102.26 mm (4.026-in.)
- The orifice plate has a beta = 0.65
- The DP transmitter has a full-scale value of 50 kPa (200.1 inH<sub>2</sub>O) and a signal reading of 17.6 mA
- The desired flow rate is m<sup>3</sup>/hr

Using the volumetric flow rate equation for an orifice plate:

$$Q_A = NCEd^2 \sqrt{\frac{\Delta P}{\rho}}$$

Where in SI units:

- N* 0.1264 (from [Table 3.2](#))
- C* Orifice plate coefficient = 0.60
- E*  $1/\sqrt{1-(0.65)^4} = 1.1033$
- d*  $0.65 \times 102.26 \text{ mm} = 66.47 \text{ mm (2.617-in.)}$
- $\Delta P$   $(17.6 - 4)/16 \times 50 = 42.5 \text{ kPa (170.9 inH}_2\text{O)}$
- $\rho$  Fluid density = 993 kg/m<sup>3</sup> (62.0 lb<sub>m</sub>/ft<sup>3</sup>) (from [Figure 2.3](#))

The calculation is:

$$Q_A = 0.1264 \times 0.60 \times 1.1033 \times (66.47)^2 \times \sqrt{170.9/993} = 153.4 \text{ m}^3/\text{hr}$$

## 11.6 DP Flow Meter Operation Checklist

The following list includes a summary of things to check to ensure that the DP flow meter is operating properly.

1. Is there sufficient upstream and downstream straight piping for the primary element installed?
2. Are impulse lines free of cracks, kinks, or other physical deformities?
3. Are there leaks anywhere in the impulse piping and transmitter system?
4. Are all connections in the system torqued to the proper specifications?
5. Is the process at risk of overheating or freezing? If so, are proper temperature management methods in place such as insulation jackets or heat tracing?
6. Is there a risk of buildup of solids in the impulse lines? This could lead to partially obstructed or fully blocked lines. The DP measurement will be different depending on if one or both are plugged.
7. If a purge is utilized, is the pressure high enough to clear out any blockages?
8. Are there abrasive particulates in the process that could damage any process wetted components of the system such as the primary element or sensor diaphragms?
9. Is the chemistry of the process compatible with flow meter materials of construction?
10. Are the components installed according to recommended installation guidelines in the reference manuals?

11. Is the primary element installed according to manufacturer or vendor guidelines?
12. Is the high-pressure side of the transmitter connected to the upstream fitting?
13. For liquid, is the transmitter below the process connection to prevent trapping gases?
14. For gas, is the transmitter mounted above the process connection to prevent accumulation of liquids?
15. Are process isolation valves, either in the manifold or impulse piping, fully open?
16. Are equalization valves, either in the manifold or impulse piping, fully closed?
17. Are all wires to the transmitter installed correctly and tightened securely?
18. Does the transmitter have the appropriate amount of clean power?
19. Has the transmitter been grounded according to the manufacturer's recommendations?
20. Is the transmitter housing cover fully closed? Is there metal-to-metal contact made between the cover and the transmitter housing body?
21. Are the conduit entries sealed properly to prevent electronics damage due to water ingress or foreign particulate?
22. Are the communication wires a suitable distance away from heavy machinery or other sources of AC noise?
23. Is there concern for transients coming down the line? If so, does the device have transient protection that is installed properly?
24. For HART communication, is there at least 250 ohms of resistance in the line?
25. Does all test equipment work, and is it within the valid operational time period?
26. If an RTD is present, are the correct wires installed at the correct terminals? Has the RTD been checked for continuity and the proper resistance?
27. If the flow meter system output is read remotely, is the scaling correct so that the local flow rate value is the same as the central system?
28. Has the DP transmitter zero been trimmed recently at operating conditions? If not, check the zero trim.
29. Is the configured primary element type, size, pipe ID, and fluid density correct for the application?
30. Is the functional output of the DP transmitter (linear or square root) appropriate for the flow meter?
31. Is the flow rate, based on the square root relationship with differential pressure, being calculated in either the control system or transmitter, but not both?
32. Is the transmitter ranged according to the application? Is the displayed or calculated flow rate within the expected value for the system?
33. Is the transmitter addressed so that it can be recognized by the host system?

### 11.7 Additional Information

For more information on Emerson's Rosemount DP flow products, consult the PDSs, Quick Start Guides, and reference manuals on [Emerson.com/DPFlow](http://Emerson.com/DPFlow), or consult your local Emerson representative.





# 12

## Engineering Data

Topic	Page
12.1 Standard Specifications for Pressure-Retaining Materials	272
12.2 Material Properties for Pressure-Containing Components	279
12.3 Physical Constants of Hydrocarbons	281
12.4 Specific Heat Ratio	284
12.5 Physical Constants of Various Fluids	285
12.6 Properties of Water	288
12.7 Properties of Saturated Steam	289
12.8 Properties of Superheated Steam	298

## 12.1 Standard Specifications for Pressure-Retaining Materials

See [Section 12.2](#) for additional specifications, cross-referenced to material code numbers.

### 1. Cast Carbon Steel ASTM A216 Grade WCC:

Temperature range:

- -20 to 800 °F (-30 to 427 °C)

Composition (%):

- C = 0.25 max
- Mn = 1.2 max
- P = 0.035 max
- S = 0.035 max
- Si = 0.6 max

### 2. Cast Carbon Steel ASTM A352 Grade LCC:

Temperature range:

- -50 to 650 °F (-45 to 343 °C)

Composition (%):

- Same as ASTM A216 grade WCC

### 3. Carbon Steel Bar AISI 1018, UNS G10180:

Temperature range:

- -20 to 800 °F (-29 to 427 °C)

Composition (%):

- C = 0.14 to 0.2
- Mn = 0.6 to 0.9
- P = 0.04 max
- S = 0.05 max

### 4. Leaded Steel Bar AISI 12L14, UNS G12144:

Temperature range:

- -20 to 800 °F (-29 to 427 °C)

Composition (%):

- C = 0.15 max
- Mn = 0.85 to 1.15
- P = 0.04 to 0.09
- S = 0.26 to 0.35
- Pb = 0.15 to 0.35

### 5. AISI 4140 Cr-Mo Steel:

Similar to ASTM A193 Grade B7 bolt material.

Temperature range:

- -55 to 1100 °F (-48 to 538 °C)

Composition (%):

- C = 0.38 to 0.43
- Mn = 0.75 to 1.0
- P = 0.035 max
- S = 0.040 max
- Si = 0.15 to 0.35
- Cr = 0.8 to 1.1
- Mo = 0.15 to 0.25
- Fe = Remainder

### 6. Forged 3-1/2% Nickel Steel ASTM A352 Grade LC3:

Temperature range:

- -150 to 650 °F (-101 to 343 °C)

Composition (%):

- C = 0.15 max
- Mn = 0.5 to 0.8
- P = 0.04 max
- S = 0.045 max
- Si = 0.6 max
- Ni = 3.0 to 4.0

### 7. Cast Cr-Mo Steel ASTM A217 Grade WC6:

Temperature range:

- -20 to 1100 °F (-30 to 595 °C)

Composition (%):

- C = 0.05 to 0.2
- Mn = 0.5 to 0.8
- P = 0.035 max
- S = 0.035 max
- Si = 0.60 max
- Cr = 1.0 to 1.5
- Mo = 0.45 to 0.65



### 8. Cast Cr-Mo Steel ASTM A217 Grade WC9:

Temperature range:

- -20 to 1100 °F (-30 to 595 °C)

Composition (%):

- C = 0.05 to 0.18
- Mn = 0.4 to 0.7
- P = 0.035 max
- S = 0.035 max
- Si = 0.6 max
- Cr = 2.0 to 2.75
- Mo = 0.9 to 1.2

### 9. Forged Cr-Mo Steel ASTM A182 Grade F22:

Temperature range:

- -20 to 1100 °F (-30 to 593 °C)

Composition (%):

- C = 0.05 to 0.15
- Mn = 0.3 to 0.6
- P = 0.04 max
- S = 0.04 max
- Si = 0.5 max
- Cr = 2.0 to 2.5
- Mo = 0.87 to 1.13

### 10. Cast Cr-Mo Steel ASTM A217 Grade C5:

Temperature range:

- -20 to 1200 °F (-30 to 649 °C)

Composition (%):

- C = 0.2 max
- Mn = 0.4 to 0.7
- P = 0.04 max
- S = 0.045 max
- Si = 0.75 max
- Cr = 4.0 to 6.5
- Mo = 0.45 to 0.65

### 11. Type 302 Stainless Steel ASTM A479 Grade UNS S30200:

Temperature range:

- -325 to 750 °F (-198 to 399 °C)

Composition (%):

- C = 0.15 max
- Mn = 2.0 max
- P = 0.045 max
- S = 0.03 max
- Si = 1.0 max
- Cr = 17.0 to 19.0
- Ni = 8.0 to 10.0
- N = 0.1 max
- Fe = Remainder

### 12. Type 304L Stainless Steel ASTM A479 Grade UNS S30403:

Temperature range:

- -425 to 800 °F (-254 to 425 °C)

Composition (%):

- C = 0.03 max
- Mn = 2.0 max
- P = 0.045 max
- S = 0.03 max
- Si = 1.0 max
- Cr = 18.0 to 20.0
- Ni = 8.0 to 12.0
- Fe = Remainder

### 13. Cast Type 304L Stainless Steel ASTM A351 Grade CF3:

Temperature range:

- -425 to 800 °F (-254 to 425 °C)

Composition (%):

- C = 0.03 max
- Mn = 1.5 max
- Si = 2.0 max
- S = 0.040 max
- P = 0.040 max
- Cr = 17.0 to 21.0
- Ni = 8.0 to 11.0
- Mo = 0.50 max

### 14. Type 316L Stainless Steel ASTM A479 Grade UNS S31603:

Temperature range:

- -425 to 850 °F (-254 to 450 °C)

Composition (%):

- C = 0.03 max
- Mn = 2.0 max
- P = 0.045 max
- S = 0.03 max
- Si = 1.0 max
- Cr = 16.0 to 18.0
- Ni = 10.0 to 14.0
- Mo = 2.0 to 3.0
- Fe = Remainder

### 15. Type 316 Stainless Steel ASTM A479 Grade UNS S31600:

Temperature range:

- -425 to 1500 °F (-255 to 816 °C)
- Above 1000 °F (538 °C),  
0.04 C minimum required

Composition (%):

- C = 0.08 max
- Mn = 2.0 max
- P = 0.045 max
- S = 0.03 max
- Si = 1.0 max
- Cr = 16.0 to 18.0
- Ni = 10.0 to 14.0
- Mo = 2.0 to 3.0
- Fe = Remainder

### 16. Cast Type 316 Stainless Steel ASTM A351 Grade CF8M:

Temperature range:

- -425 to 1500 °F (-254 to 816 °C)
- Above 1000 °F (538 °C),  
0.04 C minimum required

Composition (%):

- C = 0.08 max
- Mn = 1.5 max
- Si = 1.5 max
- P = 0.04 max
- S = 0.04 max
- Cr = 18.0 to 21.0
- Ni = 9.0 to 12.0
- Mo = 2.0 to 3.0

### 17. Type 317 Stainless Steel ASTM A479 Grade UNS S31700:

Temperature range:

- -325 to 1500 °F (-198 to 816 °C)
- Above 1000 °F (538 °C),  
0.04 C minimum required

Composition (%):

- C = 0.08 max
- Mn = 2.0 max
- P = 0.045 max
- S = 0.03 max
- Si = 1.0 max
- Cr = 18.0 to 20.0
- Ni = 11.0 to 15.0
- Mo = 3.0 to 4.0
- Fe = Remainder

### 18. Cast Type 317 Stainless Steel ASTM A351 Grade CG8M:

Temperature range:

- -325 to 1000 °F (-198 to 538 °C)

Composition (%):

- C = 0.08 max
- Mn = 1.5 max
- Si = 1.5 max
- P = 0.04 max
- S = 0.04 max
- Cr = 18.0 to 21.0
- Ni = 9.0 to 13.0
- Mo = 3.0 to 4.0

### 19. Type 410 Stainless Steel ASTM A479 Grade S41000:

Temperature range:

- -20 to 1000 °F (-29 to 538 °C)

Composition (%):

- C = 0.08 to 0.15
- Mn = 1.0 max
- P = 0.04 max
- S = 0.03 max
- Si = 1.0 max
- Cr = 11.5 to 13.5
- Fe = Remainder

### 20. Type 17-4PH Stainless Steel ASTM A564 Grade 630, UNS S17400:

Temperature range:

- -20 to 650 °F (-29 to 343 °C)

Composition (%):

- C = 0.07 max
- Mn = 1.0 max
- Si = 1.0 max
- P = 0.04 max
- S = 0.03 max
- Cr = 15.0 to 17.5
- Nb = 0.15 to 0.45
- Cu = 3.0 to 5.0
- Ni = 3.0 to 5.0
- Fe = Remainder

### 21. Type 254 SMO Stainless Steel ASTM A479 Grade UNS S31254:

Temperature range:

- -325 to 750 °F (-198 to 399 °C)

Composition (%):

- C = 0.02 max
- Mn = 1.0 max
- P = 0.03 max
- S = 0.01 max
- Si = 0.8 max
- Cr = 18.5 to 20.5
- Ni = 17.5 to 18.5
- Mo = 6.0 to 6.5
- N = 0.18–0.22
- Fe = Remainder

### 22. Cast Type 254 SMO Stainless Steel ASTM A351 Grade CK3MCuN:

Temperature range:

- -325 to 750 °F (-198 to 399 °C)

Composition (%):

- C = 0.025 max
- Mn = 1.2 max
- Si = 1.0 max
- P = 0.045 max
- S = 0.01 max
- Cr = 19.5 to 20.5
- Ni = 17.5 to 19.5
- Mo = 6.0 to 7.0
- N = 0.18 to 0.24

### 23. Type 2205, S31803 Duplex Stainless Steel ASTM A479 Grade UNS S31803:

Temperature range:

- -60 to 600 °F (-50 to 316 °C)

Composition (%):

- C = 0.03 max
- Mn = 2.0 max
- P = 0.03 max
- S = 0.02 max
- Si = 1.0 max
- Cr = 21.0 to 23.0
- Ni = 4.5 to 6.5
- Mo = 2.5 to 3.5
- N = 0.08 to 0.2
- Fe = Remainder

### 24. Cast Type 2205, S31803 Stainless Steel ASTM A890 Grade 4a, CD3MN:

Temperature range:

- -60 to 600 °F (-50 to 316 °C)

Composition (%):

- C = 0.03 max
- Mn = 1.5 max
- Si = 1.0 max
- P = 0.04 max
- S = 0.02 max
- Cr = 21.0 to 23.5
- Ni = 4.5 to 6.5
- Mo = 2.5 to 3.5
- Cu = 1.0 max
- N = 0.1 to 0.3
- Fe = Remainder

### 25. Cast Iron ASTM A126 Class B, UNS F12102:

Temperature range:

- -20 to 450 °F (-29 to 232 °C)

Composition (%):

- P = 0.75 max
- S = 0.15 max

### 26. Cast Iron ASTM A126 Class C, UNS F12802:

Temperature range:

- -20 to 450 °F (-29 to 232 °C)

Composition (%):

- $P = 0.75 \text{ max}$
- $S = 0.15 \text{ max}$

### 27. Ductile Iron ASTM A395 Type 60-40-18:

Temperature range:

- -20 to 650 °F (-29 to 343 °C)

Composition (%):

- $C = 3.0 \text{ min}$
- $Si = 2.5 \text{ max}$
- $P = 0.08 \text{ max}$

### 28. Ductile Ni-Resist Iron ASTM A439 Type D-2B, UNS F43001:

Temperature range for non-pressure-retaining components:

- -20 to 1400 °F (-29 to 760 °C)

Composition (%):

- $C = 3.0 \text{ max}$
- $Si = 1.5 \text{ to } 3.00$
- $Mn = 0.70 \text{ to } 1.25$
- $P = 0.08 \text{ max}$
- $Ni = 18.0 \text{ to } 22.0$
- $Cr = 2.75 \text{ to } 4.0$

### 29. Leaded Tin Bronze ASTM B61, UNS C92200:

Temperature range:

- -325 to 550 °F (-198 to 288 °C)

Composition (%):

- $Cu = 86.0 \text{ to } 90.0$
- $Sn = 5.5 \text{ to } 6.5$
- $Pb = 1.0 \text{ to } 2.0$
- $Zn = 3.0 \text{ to } 5.0$
- $Ni = 1.0 \text{ max}$
- $Fe = 0.25 \text{ max}$
- $S = 0.05 \text{ max}$
- $P = 0.05 \text{ max}$

### 30. Tin Bronze ASTM B584 Grade UNS C90500:

Temperature range:

- -325 to 400 °F (-198 to 204 °C)

Composition (%):

- $Cu = 86.0 \text{ to } 89.0$
- $Sn = 9.0 \text{ to } 11.0$
- $Pb = 0.30 \text{ max}$
- $Zn = 1.0 \text{ to } 3.0$
- $Ni = 1.0 \text{ max}$
- $Fe = 0.2 \text{ max}$
- $S = 0.05 \text{ max}$
- $P = 0.05 \text{ max}$

### 31. Manganese Bronze ASTM B584 Grade UNS C86500:

Temperature range:

- -325 to 350 °F (-198 to 177 °C)

Composition (%):

- $Cu = 55.0 \text{ to } 60.0$
- $Sn = 1.0 \text{ max}$
- $Pb = 0.4 \text{ max}$
- $Ni = 1.0 \text{ max}$
- $Fe = 0.4 \text{ to } 2.0$
- $Al = 0.5 \text{ to } 1.5$
- $Mn = 0.1 \text{ to } 1.5$
- $Zn = 36.0 \text{ to } 42.0$

### 32. Cast Aluminum Bronze ASTM B148 Grade UNS C95400:

Temperature range:

- -325 to 600 °F (-198 to 316 °C)

Composition (%):

- $Cu = 83.0 \text{ min}$
- $Al = 10.0 \text{ to } 11.5$
- $Fe = 3.0 \text{ to } 5.0$
- $Mn = 0.50 \text{ max}$
- $Ni = 1.5 \text{ max}$

**33. Cast Aluminum Bronze ASTM B148 Grade UNS C95800:**

Temperature range:

- -325 to 500 °F (-198 to 260 °C)

Composition (%):

- Cu = 79.0 min
- Al = 8.5 to 9.5
- Fe = 3.5 to 4.5
- Mn = 0.8 to 1.5
- Ni = 4.0 to 5.0
- Si = 0.1 max

**34. B16 Yellow Brass Bar ASTM B16 Grade UNS C36000, 1/2 Hard:**

Temperature range for non-pressure- retaining components:

- -325 to 400 °F (-198 to 204 °C)

Composition (%):

- Cu = 60.0 to 63.0
- Pb = 2.5 to 3.0
- Fe = 0.35 max
- Zn = Remainder

**35. Naval Brass Forgings ASTM B283 Alloy UNS C46400:**

Temperature range:

- -325 to 400 °F (-198 to 204 °C)

Composition (%):

- Cu = 59.0 to 62.0
- Sn = 0.5 to 1.0
- Pb = 0.2 max
- Fe = 0.15 max
- Zn = Remainder

**36. Aluminum Bar ASTM B211 Alloy UNS A96061-T6:**

Temperature range:

- -452 to 400 °F (-269 to 204 °C)

Composition (%):

- Si = 0.4 to 0.8
- Fe = 0.7 max
- Cu = 0.15 to 0.4
- Zn = 0.25 max
- Mg = 0.8 to 1.2
- Mn = 0.15 max
- Cr = 0.04 to 0.35
- Ti = 0.15 max
- Other Elements = 0.15 max
- Al = Remainder

**37. Cobalt-base Alloy No.6 Cast UNS R30006, Weld filler CoCr-A:**

Temperature range for non-pressure-retaining components:

- -325 to 1800 °F (-198 to 980 °C)

Composition (%):

- C = 0.9 to 1.4
- Mn = 1.0 max
- W = 3.5 to 6.0
- Ni = 3.0 max
- Cr = 26.0 to 31.0
- Mo = 1.5 max
- Fe = 3.0 max
- Si = 1.5 max
- Co = Remainder

**38. Ni-Cu Alloy Bar K500 ASTM B865 Grade N05500:**

Temperature range for non-pressure-retaining components:

- -325 to 900 °F (-198 to 482 °C)

Composition (%):

- Ni = 63.0 min
- Fe = 2.0 max
- Mn = 1.5 max
- Si = 0.5 max
- C = 0.18 max
- S = 0.01 max
- Al = 2.3 to 3.15
- Ti = 0.35 to 0.85
- Cu = Remainder

**39. Cast Ni-Cu Alloy 400 ASTM A494 Grade M35-1:**

Temperature range:

- -325 to 900 °F (-198 to 475 °C)

Composition (%):

- Cu = 27.0 to 33.0
- C = 0.35 max
- Mn = 1.5 max
- Fe = 3.5 max
- S = 0.02 max
- P = 0.03 max
- Si = 1.25 max
- Nb = 0.5 max
- Ni = Remainder

### 40. Ni-Cr-Mo Alloy C276 Bar ASTM B574 Grade N10276:

Temperature range:

- -325 to 1250 °F (-198 to 677 °C)

Composition (%):

- Cr = 14.5 to 16.5
- Fe = 4.0 to 7.0
- W = 3.0 to 4.5
- C = 0.01 max
- Si = 0.08 max
- Co = 2.5 max
- Mn = 1.0 max
- V = 0.35 max
- Mo = 15.0 to 17.0
- P = 0.04
- S = 0.03
- Ni = Remainder

### 41. Ni-Cr-Mo Alloy C ASTM A494 CW2M:

Temperature range:

- -325 to 1000 °F (-198 to 538 °C)

Composition (%):

- Cr = 15.5 to 17.5
- Fe = 2.0 max
- W = 1.0 max
- C = 0.02 max
- Si = 0.8 max
- Mn = 1.0 max
- Mo = 15.0 to 17.5
- P = 0.03
- S = 0.02
- Ni = Remainder

### 42. Ni-Mo Alloy B2 Bar ASTM B335 Grade B2, UNS N10665:

Temperature range:

- -325 to 800 °F (-198 to 427 °C)

Composition (%):

- Cr = 1.0 max
- Fe = 2.0 max
- C = 0.02 max
- Si = 0.1 max
- Co = 1.0 max
- Mn = 1.0 max
- Mo = 26.0 to 30.0
- P = 0.04 max
- S = 0.03 max
- Ni = Remainder

### 43. Cast Ni-Mo Alloy B2 ASTM A494 N7M:

Temperature range:

- -325 to 1000 °F (-198 to 538 °C)

Composition (%):

- Cr = 1.0 max
- Fe = 3.0 max
- C = 0.07 max
- Si = 1.0 max
- Mn = 1.0 max
- Mo = 30.0 to 33.0
- P = 0.03 max
- S = 0.02 max
- Ni = Remainder

## 12.2 Material Properties for Pressure-Containing Components

The material codes in this table correspond to the standard specifications for materials listings in [Section 12.1](#).

Material Code	Minimum Mechanical Properties				Modulus of Elasticity at 70 °F (21 °C) psi (MPa)	Typical Brinell Hardness
	Tensile Strength ksi (MPa)	Yield Strength ksi (MPa)	Elongation in 2-in. (50 mm)	Reduction in Area (%)		
1	70-95 (485-655)	40 (275)	22	35	27.9E6 (19.2E4)	137-187
2	70-95 (485-655)	40 (275)	22	35	27.9E6 (19.2E4)	137-187
3	57 (390) typical	42 (290) typical	37 typical	67 typical	30.0E6 (20.7E4)	111
4	79 (545) typical	71 (490) typical	16 typical	52 typical	30.0E6 (20.7E4)	163
5 <sup>1</sup>	125 (860)	105 (725) typical	16	50	29.9E6 (20.6E4)	258
6	70-95 (485-655)	40 (275)	24	35	27.9E6 (19.2E4)	140-190
7	70-95 (485-655)	40 (275)	20	35	29.9E6 (20.6E4)	147-200
8	70-95 (485-655)	40 (275)	20	35	29.9E6 (20.6E4)	147-200
9	75-100 (515-690)	45(310)	19	40	29.9E6 (20.6E4)	156-207 required
10	90-115 (620-795)	60 (415)	18	35	27.4E6 (19.0E4)	176-255
11	75 (515)	30 (205)	30	40	28.3E6 (19.3E4)	150
12	70 (485)	25 (170)	30	40	29.0E6 (20.0E4)	150
13	70 (485)	30 (205)	35	–	29.0E6 (20.0E4)	150
14	70 (485)	25 (170)	40	50	28.3E6 (19.3E4)	150-170
15 <sup>2</sup>	75 (515)	30 (205)	30	40	28.3E6 (19.5E4)	150
16	70 (485)	30 (205)	30	–	28.3E6 (19.5E4)	163
17	75 (515)	30 (205)	30	40	28.3E6 (19.5E4)	170
18	75 (515)	35 (240)	25	–	28.3E6 (19.5E4)	170
19 <sup>3</sup>	70 (480)	40 (275)	20	45	29.2E6 (20.1E4)	241
20 <sup>4</sup>	145 (1000)	125 (860)	13	45	29E6 (20.0E4)	311 min
21	95 (665)	45 (310)	35	50	29.0E6 (20.0E4)	90 HRB
22	80 (550)	38 (260)	35	–	29.0E6 (20.0E4)	82 HRB
23	90 (620)	65 (450)	25	–	30.5E6 (21.0E4)	290 max
24	90 (620)	65 (450)	25	–	30.5E6 (21.0E4)	98 HRB
25 <sup>5</sup>	31 (214)	–	–	–	13.4E6 (9.2E4)	160-220
26 <sup>6</sup>	41 (282)	–	–	–	13.4E6 (9.2E4)	230
27	60 (415)	40 (276)	18	–	23E6 (16E4)	143-187
28	58 (400)	30 (205)	8	–	–	139-202
29	34 (234)	16 (110)	24	–	14.0E6 (9.7E4)	65
30	40 (275)	18 (124)	20	–	14.0 (9.7E4)	75
31	65 (448)	25 (172)	20	–	15.3E6 (10.5E4)	97

### 12.2 Material Properties for Pressure-Containing Components, continued.

Material Code	Minimum Mechanical Properties				Modulus of Elasticity at 70 °F (21 °C) psi (MPa)	Typical Brinell Hardness
	Tensile Strength ksi (MPa)	Yield Strength ksi (MPa)	Elongation in 2-in. (50 mm)	Reduction in Area (%)		
32	75 (515)	30 (205)	12	–	16E6 (11.0E4)	150 min
33	85 (585)	35 (240)	15	–	16E6 (11.0E4)	159
34	55 (380)	25 (170)	10	–	14E6 (9.6E4)	55-75 HRB required
35	60 (415)	27 (185)	25	–	15.0E6 (10.3E4)	131-142
36	42 (290)	35 (241)	10	–	9.9E6 (6.8E4)	95
37 <sup>7</sup>	154 (1060) typical	93 (638) typical	17 typical	–	30E6 (21E4)	37 HRC
38	140 (965)	100 (690)	20	–	26E6 (17.9E4)	265-325
39	65 (450)	25 (170)	25	–	23E6 (15.8E4)	110-150
40	100 (689)	41 (283)	40	–	29.8E6 (20.5E4)	210
41	72 (496)	40 (275)	20	–	30.8E6 (21.2E4)	150-185
42	110 (760)	51 (350)	40	–	31.4E6 (21.7E4)	238
43	76 (525)	40 (275)	20	–	28.5E6 (19.7E4)	180

1. Tempered 1200 °F (650 °C).

2. Annealed.

3. ASTM A479 Annealed Condition.

4. ASTM A564 Grade 630 Condition H1075.

5. A126 Cl.B 1.125-in. (95 mm) diameter bar.

6. A126 Cl.C 1.125-in. (95 mm) diameter bar.

7. Wrought.



## 12.3 Physical Constants of Hydrocarbons

No.	Compound	Formula	Molecular Weight	Boiling Point at 14.696 psia (°F)	Vapor Pressure at 100 °F (psia)	Freezing Point at 14.696 psia (°F)
1	Methane	CH <sub>4</sub>	16.043	-258.69	(5000) <sup>1</sup>	-296.46 <sup>2</sup>
2	Ethane	C <sub>2</sub> H <sub>6</sub>	30.070	-127.48	(800) <sup>1</sup>	-297.89 <sup>2</sup>
3	Propane	C <sub>3</sub> H <sub>8</sub>	44.097	-43.67	190	-305.84 <sup>2</sup>
4	n-Butane	C <sub>4</sub> H <sub>10</sub>	58.124	31.10	51.6	-217.05
5	Isobutane	C <sub>4</sub> H <sub>10</sub>	58.124	10.90	72.2	-255.29
6	n-Pentane	C <sub>5</sub> H <sub>12</sub>	72.151	96.92	15.570	-201.51
7	Isopentane	C <sub>5</sub> H <sub>12</sub>	72.151	82.12	20.44	-255.83
8	Neopentane	C <sub>5</sub> H <sub>12</sub>	72.151	49.10	35.90	2.17
9	n-Hexane	C <sub>6</sub> H <sub>14</sub>	86.178	155.72	4.956	-139.58
10	2-Methylpentane	C <sub>6</sub> H <sub>14</sub>	86.178	140.47	6.767	-244.63
11	3-Methylpentane	C <sub>6</sub> H <sub>14</sub>	86.178	145.89	6.098	–
12	Neohexane	C <sub>6</sub> H <sub>14</sub>	86.178	121.52	9.856	-147.72
13	2,3-Dimethylbutane	C <sub>6</sub> H <sub>14</sub>	86.178	136.36	7.404	-199.38

No.	Compound	Formula	Critical Constants		Specific Gravity at 14.696 psia	
			Critical Temperature (°F)	Critical Pressure (psia)	Liquid <sup>3,4</sup> 60/60 °F	Gas at 60 °F (Air=1) <sup>5</sup>
1	Methane	CH <sub>4</sub>	-116.63	667.8	0.3 <sup>6</sup>	0.5539
2	Ethane	C <sub>2</sub> H <sub>6</sub>	90.09	707.8	0.3564 <sup>7</sup>	1.0382
3	Propane	C <sub>3</sub> H <sub>8</sub>	206.01	616.3	0.5077 <sup>7</sup>	1.5225
4	n-Butane	C <sub>4</sub> H <sub>10</sub>	305.65	550.7	0.5844 <sup>7</sup>	2.0068
5	Isobutane	C <sub>4</sub> H <sub>10</sub>	274.98	529.1	0.5631 <sup>7</sup>	2.0068
6	n-Pentane	C <sub>5</sub> H <sub>12</sub>	385.7	488.6	0.6310	2.4911
7	Isopentane	C <sub>5</sub> H <sub>12</sub>	369.10	490.4	0.6247	2.4911
8	Neopentane	C <sub>5</sub> H <sub>12</sub>	321.13	464.0	0.5967 <sup>7</sup>	2.4911
9	n-Hexane	C <sub>6</sub> H <sub>14</sub>	453.7	436.9	0.6640	2.9753
10	2-Methylpentane	C <sub>6</sub> H <sub>14</sub>	435.83	436.6	0.6579	2.9753
11	3-Methylpentane	C <sub>6</sub> H <sub>14</sub>	448.3	453.1	0.6689	2.9753
12	Neohexane	C <sub>6</sub> H <sub>14</sub>	420.13	446.8	0.6540	2.9753
13	2,3-Dimethylbutane	C <sub>6</sub> H <sub>14</sub>	440.29	453.5	0.6664	2.9753

### 12.3 Physical Constants of Hydrocarbons, continued.

No.	Compound	Formula	Molecular Weight	Boiling Point at 14.696 psia (°F)	Vapor Pressure at 100 °F (psia)	Freezing Point at 14.696 psia (°F)
14	n-Heptane	C <sub>7</sub> H <sub>16</sub>	100.205	209.17	1.620	-131.05
15	2-Methylhexane	C <sub>7</sub> H <sub>16</sub>	100.205	194.09	2.271	-180.89
16	3-Methylhexane	C <sub>7</sub> H <sub>16</sub>	100.205	197.32	2.130	–
17	3-Ethylpentane	C <sub>7</sub> H <sub>16</sub>	100.205	200.25	2.012	-181.48
18	2,2-Dimethylpentane	C <sub>7</sub> H <sub>16</sub>	100.205	174.54	3.492	-190.86
19	2,4-Dimethylpentane	C <sub>7</sub> H <sub>16</sub>	100.205	176.89	3.292	-182.63
20	3,3-Dimethylpentane	C <sub>7</sub> H <sub>16</sub>	100.205	186.91	2.773	-210.01
21	Triptane	C <sub>7</sub> H <sub>16</sub>	100.205	177.58	3.374	-12.82
22	n-Octane	C <sub>8</sub> H <sub>18</sub>	114.232	258.22	0.537	-70.18
23	Disobutyl	C <sub>8</sub> H <sub>18</sub>	114.232	228.39	1.101	-132.07
24	Isooctane	C <sub>8</sub> H <sub>18</sub>	114.232	210.63	1.708	-161.27
25	n-Nonane	C <sub>9</sub> H <sub>20</sub>	128.259	303.47	0.179	-64.28
26	n-Decane	C <sub>10</sub> H <sub>22</sub>	142.286	345.48	0.0597	-21.36
27	Cyclopentane	C <sub>5</sub> H <sub>10</sub>	70.135	120.65	9.914	-136.91
28	Methylcyclopentane	C <sub>6</sub> H <sub>12</sub>	84.162	161.25	4.503	-224.44

No.	Compound	Formula	Critical Constants		Specific Gravity at 14.696 psia	
			Critical Temperature (°F)	Critical Pressure (psia)	Liquid <sup>3,4</sup> 60/60 °F	Gas at 60 °F (Air=1) <sup>5</sup>
14	n-Heptane	C <sub>7</sub> H <sub>16</sub>	512.8	396.8	0.6882	3.4596
15	2-Methylhexane	C <sub>7</sub> H <sub>16</sub>	495.00	396.5	0.6830	3.4596
16	3-Methylhexane	C <sub>7</sub> H <sub>16</sub>	503.78	408.1	0.6917	3.4596
17	3-Ethylpentane	C <sub>7</sub> H <sub>16</sub>	513.48	419.3	0.7028	3.4596
18	2,2-Dimethylpentane	C <sub>7</sub> H <sub>16</sub>	477.23	402.2	0.6782	3.4596
19	2,4-Dimethylpentane	C <sub>7</sub> H <sub>16</sub>	475.95	396.9	0.6773	3.4596
20	3,3-Dimethylpentane	C <sub>7</sub> H <sub>16</sub>	505.85	427.2	0.6976	3.4596
21	Triptane	C <sub>7</sub> H <sub>16</sub>	496.44	428.4	0.6946	3.4596
22	n-Octane	C <sub>8</sub> H <sub>18</sub>	564.22	360.6	0.7068	3.9439
23	Disobutyl	C <sub>8</sub> H <sub>18</sub>	530.44	360.6	0.6979	3.9439
24	Isooctane	C <sub>8</sub> H <sub>18</sub>	519.46	372.4	0.6962	3.9439
25	n-Nonane	C <sub>9</sub> H <sub>20</sub>	610.68	332.0	0.7217	4.4282
26	n-Decane	C <sub>10</sub> H <sub>22</sub>	652.1	304.0	0.7342	4.9125
27	Cyclopentane	C <sub>5</sub> H <sub>10</sub>	461.5	653.8	0.7504	2.4215
28	Methylcyclopentane	C <sub>6</sub> H <sub>12</sub>	499.35	548.9	0.7536	2.9057

### 12.3 Physical Constants of Hydrocarbons, continued.

No.	Compound	Formula	Molecular Weight	Boiling Point at 14.696 psia (°F)	Vapor Pressure at 100 °F (psia)	Freezing Point at 14.696 psia (°F)
29	Cyclohexane	C <sub>6</sub> H <sub>12</sub>	84.162	177.29	3.264	43.77
30	Methylcyclohexane	C <sub>7</sub> H <sub>14</sub>	98.189	213.68	1.609	-195.87
31	Ethylene	C <sub>2</sub> H <sub>4</sub>	28.054	-154.62	–	-272.45 <sup>2</sup>
32	Propene	C <sub>3</sub> H <sub>6</sub>	42.081	-53.90	226.4	-301.45 <sup>2</sup>
33	1-Butene	C <sub>4</sub> H <sub>8</sub>	56.108	20.75	63.05	-301.63 <sup>2</sup>
34	Cis-2-Butene	C <sub>4</sub> H <sub>8</sub>	56.108	38.69	45.54	-218.06
35	Trans-2-Butene	C <sub>4</sub> H <sub>8</sub>	56.108	33.58	49.80	-157.96
36	Isobutene	C <sub>4</sub> H <sub>8</sub>	56.108	19.59	63.40	-220.61
37	1-Pentene	C <sub>5</sub> H <sub>10</sub>	70.135	85.93	19.115	-265.39
38	1,2-Butadiene	C <sub>4</sub> H <sub>6</sub>	54.092	51.53	(20.0) <sup>1</sup>	-213.16
39	1,3-Butadiene	C <sub>4</sub> H <sub>6</sub>	54.092	24.06	(60.0) <sup>1</sup>	-164.02
40	Isoprene	C <sub>5</sub> H <sub>8</sub>	68.119	93.30	16.672	-230.74
41	Acetylene	C <sub>2</sub> H <sub>2</sub>	26.038	-119.0 <sup>8</sup>	–	-114.0 <sup>2</sup>
42	Benzene	C <sub>6</sub> H <sub>6</sub>	78.114	176.17	3.224	41.96
43	Toluene	C <sub>7</sub> H <sub>8</sub>	92.141	231.13	1.032	-138.94

No.	Compound	Formula	Critical Constants		Specific Gravity at 14.696 psia	
			Critical Temperature (°F)	Critical Pressure (psia)	Liquid <sup>3,4</sup> 60/60 °F	Gas at 60 °F (Air=1) <sup>1</sup>
29	Cyclohexane	C <sub>6</sub> H <sub>12</sub>	536.7	591.0	0.7834	2.9057
30	Methylcyclohexane	C <sub>7</sub> H <sub>14</sub>	570.27	503.5	0.7740	3.3900
31	Ethylene	C <sub>2</sub> H <sub>4</sub>	48.58	729.8	–	0.9686
32	Propene	C <sub>3</sub> H <sub>6</sub>	196.9	669.0	0.5220 <sup>7</sup>	1.4529
33	1-Butene	C <sub>4</sub> H <sub>8</sub>	295.6	583.0	0.6013 <sup>7</sup>	1.9372
34	Cis-2-Butene	C <sub>4</sub> H <sub>8</sub>	324.37	610.0	0.6271 <sup>7</sup>	1.9372
35	Trans-2-Butene	C <sub>4</sub> H <sub>8</sub>	311.86	595.0	0.6100 <sup>7</sup>	1.9372
36	Isobutene	C <sub>4</sub> H <sub>8</sub>	292.55	580.0	0.6004 <sup>7</sup>	1.9372
37	1-Pentene	C <sub>5</sub> H <sub>10</sub>	376.93	590.0	0.6457	2.4215
38	1,2-Butadiene	C <sub>4</sub> H <sub>6</sub>	(339.0) <sup>1</sup>	(653.0) <sup>1</sup>	0.6587	1.8676
39	1,3-Butadiene	C <sub>4</sub> H <sub>6</sub>	306.0	628.0	0.6272 <sup>7</sup>	1.8676
40	Isoprene	C <sub>5</sub> H <sub>8</sub>	(412.0) <sup>1</sup>	(558.4) <sup>1</sup>	0.6861	2.3519
41	Acetylene	C <sub>2</sub> H <sub>2</sub>	95.31	890.4	0.615 <sup>9</sup>	0.8990
42	Benzene	C <sub>6</sub> H <sub>6</sub>	552.22	710.4	0.8844	2.6969
43	Toluene	C <sub>7</sub> H <sub>8</sub>	605.55	595.9	0.8718	3.1812

## 12.3 Physical Constants of Hydrocarbons, continued.

No.	Compound	Formula	Molecular Weight	Boiling Point at 14.696 psia (°F)	Vapor Pressure at 100 °F (psia)	Freezing Point at 14.696 psia (°F)
44	Ethylbenzene	C <sub>8</sub> H <sub>10</sub>	106.168	277.16	0.371	-138.91
45	o-Xylene	C <sub>8</sub> H <sub>10</sub>	106.168	291.97	0.264	-13.30
46	m-Xylene	C <sub>8</sub> H <sub>10</sub>	106.168	282.41	0.326	-54.12
47	p-Xylene	C <sub>8</sub> H <sub>10</sub>	106.168	281.05	0.342	55.86
48	Styrene	C <sub>8</sub> H <sub>8</sub>	104.152	293.29	(0.24) <sup>1</sup>	-23.10
49	Isopropylbenzene	C <sub>9</sub> H <sub>12</sub>	120.195	306.34	0.188	-140.82

No.	Compound	Formula	Critical Constants		Specific Gravity at 14.696 psia	
			Critical Temperature (°F)	Critical Pressure (psia)	Liquid <sup>3,4</sup> 60/60 °F	Gas at 60 °F (Air=1) <sup>5</sup>
44	Ethylbenzene	C <sub>8</sub> H <sub>10</sub>	651.24	523.5	0.8718	3.6655
45	o-Xylene	C <sub>8</sub> H <sub>10</sub>	675.0	541.4	0.8848	3.6655
46	m-Xylene	C <sub>8</sub> H <sub>10</sub>	651.02	513.6	0.8687	3.6655
47	p-Xylene	C <sub>8</sub> H <sub>10</sub>	649.6	509.2	0.8657	3.6655
48	Styrene	C <sub>8</sub> H <sub>8</sub>	706.0	580.0	0.9110	3.5959
49	Isopropylbenzene	C <sub>9</sub> H <sub>12</sub>	676.4	465.4	0.8663	4.1498

1. ( )—Estimated values.
2. At saturation pressure (triple point).
3. Air saturated hydrocarbons.
4. Absolute values from weights in vacuum.
5. Calculated values.
6. Apparent value for methane at 60 °F (15.5 °C).
7. Saturation pressure at 60 °F (15.5 °C).
8. Sublimation point.
9. Specific gravity, 119 °F/60 °F (sublimation point).

## 12.4 Specific Heat Ratio, *k*

Gas	Specific Heat Ratio, <i>k</i>	Gas	Specific Heat Ratio, <i>k</i>	Gas	Specific Heat Ratio, <i>k</i>	Gas	Specific Heat Ratio, <i>k</i>
Acetylene	1.38	Carbon Dioxide	1.29	0.6 Natural Gas	1.32	Steam <sup>1</sup>	1.33
Air	1.40	Ethane	1.25	Nitrogen	1.40		
Argon	1.67	Helium	1.66	Oxygen	1.40		
Butane	1.17	Hydrogen	1.40	Propane	1.21		
Carbon Monoxide	1.40	Methane	1.26	Propylene	1.15		

1. Use property tables if available for greater accuracy.

## 12.5 Physical Constants of Various Fluids

Fluid	Formula	Molecular Weight	Boiling Point (°F at 14.696 psia)	Vapor Pressure at 70 °F (psig)	Critical Temp. (°F)	Critical Pressure (psia)	Specific Gravity	
							Liquid (60/60 °F)	Gas
Acetic Acid	HC <sub>2</sub> H <sub>3</sub> O <sub>2</sub>	60.05	245	–	–	–	1.05	–
Acetone	C <sub>3</sub> H <sub>6</sub> O	58.08	133	–	455	691	0.79	2.01
Air	N <sub>2</sub> , O <sub>2</sub> , other gases	28.97	-317	–	-221	547	0.86	1.0
Alcohol, Ethyl	C <sub>2</sub> H <sub>6</sub> O	46.07	173	2.3 <sup>1</sup>	470	925	0.794	1.59
Alcohol, Methyl	CH <sub>4</sub> O	32.04	148	4.63 <sup>1</sup>	463	1174	0.796	1.11
Ammonia	NH <sub>3</sub>	17.03	-28	114	270	1636	0.62	0.59
Ammonium Chloride <sup>2</sup>	NH <sub>4</sub> Cl	–	–	–	–	–	1.07	–
Ammonium Hydroxide <sup>2</sup>	NH <sub>4</sub> OH	–	–	–	–	–	0.91	–
Ammonium Sulfate <sup>2</sup>	(NH <sub>4</sub> ) <sub>2</sub> SO <sub>4</sub>	–	–	–	–	–	1.15	–
Aniline	C <sub>6</sub> H <sub>7</sub> N	93.12	365	–	798	770	1.02	–
Argon	A	39.94	-302	–	-188	705	1.65	1.38
Beer	–	–	–	–	–	–	1.01	–
Bromine	Br <sub>2</sub>	159.84	138	–	575	–	2.93	5.52
Calcium Chloride <sup>2</sup>	CaCl <sub>2</sub>	–	–	–	–	–	1.23	–
Carbon Dioxide	CO <sub>2</sub>	44.01	-109	839	88	1072	0.801 <sup>1</sup>	1.52
Carbon Disulfide	CS <sub>2</sub>	76.1	115	–	–	–	1.29	2.63
Carbon Monoxide	CO	28.01	-314	–	-220	507	0.80	0.97
Carbon Tetrachloride	CCl <sub>4</sub>	153.84	170	–	542	661	1.59	5.31
Chlorine	Cl <sub>2</sub>	70.91	-30	85	291	1119	1.42	2.45
Chromic Acid	H <sub>2</sub> CrO <sub>4</sub>	118.03	–	–	–	–	1.21	–
Citric Acid	C <sub>6</sub> H <sub>8</sub> O <sub>7</sub>	192.12	–	–	–	–	1.54	–
Copper Sulfate <sup>2</sup>	CuSO <sub>4</sub>	–	–	–	–	–	1.17	–
Ether	(C <sub>2</sub> H <sub>5</sub> ) <sub>2</sub> O	74.12	34	–	–	–	0.74	2.55
Ferric Chloride <sup>2</sup>	FeCl <sub>3</sub>	–	–	–	–	–	1.23	–
Fluorine	F <sub>2</sub>	38.00	-305	300	1200	809	1.11	1.31
Formaldehyde	H <sub>2</sub> CO	30.03	-6	–	–	–	0.82	1.08
Formic Acid	HCO <sub>2</sub> H	46.03	214	–	–	–	1.23	–
Furfural	C <sub>5</sub> H <sub>4</sub> O <sub>2</sub>	96.08	324	–	–	–	1.16	–

### 12.5 Physical Constants of Various Fluids, continued.

Fluid	Formula	Molecular Weight	Boiling Point (°F at 14.696 psia)	Vapor Pressure at 70 °F (psig)	Critical Temp. (°F)	Critical Pressure (psia)	Specific Gravity	
							Liquid (60/60 °F)	Gas
Glycerine	C <sub>3</sub> H <sub>8</sub> O <sub>3</sub>	92.09	554	–	–	–	1.26	–
Glycol	C <sub>2</sub> H <sub>6</sub> O <sub>2</sub>	62.07	387	–	–	–	1.11	–
Helium	He	4.003	-454	–	-450	33	0.18	0.14
Hydrochloric Acid	HCl	36.47	-115	–	–	–	1.64	–
Hydrofluoric Acid	HF	20.01	66	0.9	446	–	0.92	–
Hydrogen	H <sub>2</sub>	2.016	-422	–	-400	188	0.07	0.07
Hydrogen Chloride	HCl	36.47	-115	613	125	1198	0.86	1.26
Hydrogen Sulfide	H <sub>2</sub> S	34.07	-76	252	213	1307	0.79	1.17
Isopropyl Alcohol	C <sub>3</sub> H <sub>8</sub> O	60.09	180	–	–	–	0.78	2.08
Linseed Oil	–	–	538	–	–	–	0.93	–
Magnesium Chloride <sup>2</sup>	MgCl <sub>2</sub>	–	–	–	–	–	1.22	–
Mercury	Hg	200.61	670	–	–	–	13.6	6.93
Methyl Bromide	CH <sub>3</sub> Br	94.95	38	13	376	1226	1.73	3.27
Methyl Chloride	CH <sub>3</sub> Cl	50.49	-11	59	290	969	0.99	1.74
Naphthalene	C <sub>10</sub> H <sub>8</sub>	128.16	424	–	–	–	1.14	4.43
Nitric Acid	HNO <sub>3</sub>	63.02	187	–	–	–	1.5	–
Nitrogen	N <sub>2</sub>	28.02	-320	–	-233	493	0.81	0.97
Oil, Vegetable	–	–	–	–	–	–	0.91-0.94	–
Oxygen	O <sub>2</sub>	32	-297	–	-181	737	1.14	1.105
Phosgene	COCl <sub>2</sub>	98.92	47	10.7	360	823	1.39	3.42
Phosphoric Acid	H <sub>3</sub> PO <sub>4</sub>	98.00	415	–	–	–	1.83	–
Potassium Carbonate <sup>2</sup>	K <sub>2</sub> CO <sub>3</sub>	–	–	–	–	–	1.24	–
Potassium Chloride <sup>2</sup>	KCl	–	–	–	–	–	1.16	–
Potassium Hydroxide <sup>2</sup>	KOH	–	–	–	–	–	1.24	–
Sodium Chloride <sup>2</sup>	NaCl	–	–	–	–	–	1.19	–
Sodium Hydroxide <sup>2</sup>	NaOH	–	–	–	–	–	1.27	–

### 12.5 Physical Constants of Various Fluids, continued.

Fluid	Formula	Molecular Weight	Boiling Point (°F at 14.696 psia)	Vapor Pressure at 70 °F (psig)	Critical Temp. (°F)	Critical Pressure (psia)	Specific Gravity	
							Liquid (60/60 °F)	Gas
Sodium Sulfate <sup>2</sup>	Na <sub>2</sub> SO <sub>4</sub>	–	–	–	–	–	1.24	–
Sodium Thiosulfate <sup>2</sup>	Na <sub>2</sub> S <sub>2</sub> O <sub>3</sub>	–	–	–	–	–	1.23	–
Starch	(C <sub>6</sub> H <sub>10</sub> O <sub>5</sub> ) <sub>x</sub>	–	–	–	–	–	1.50	–
Sugar Solutions <sup>2</sup>	C <sub>12</sub> H <sub>22</sub> O <sub>11</sub>	–	–	–	–	–	1.10	–
Sulfuric Acid	H <sub>2</sub> SO <sub>4</sub>	98.08	626	–	–	–	1.83	–
Sulfur Dioxide	SO <sub>2</sub>	64.6	14	34.4	316	1145	1.39	2.21
Turpentine	–	–	320	–	–	–	0.87	–
Water	H <sub>2</sub> O	18.016	212	0.9492 <sup>1</sup>	706	3208	1.00	0.62
Zinc Chloride <sup>2</sup>	ZnCl <sub>2</sub>	–	–	–	–	–	1.24	–
Zinc Sulfate <sup>3</sup>	ZnSO <sub>4</sub>	–	–	–	–	–	1.31	–

1. Vapor pressure in psia at 100 °F (39 °C).

2. Aqueous solution – 25% by weight of compound.

## 12.6 Properties of Water

Temperature (°F)	Saturation Pressure (psi, Absolute)	Weight (lb/gallon)	Specific Gravity 60/60 °F	Conversion Factor <sup>1</sup> lb/hr to gal/min
32	0.0885	8.345	1.0013	0.00199
40	0.1217	8.345	1.0013	0.00199
50	0.1781	8.340	1.0007	0.00199
60	0.2653	8.334	1.0000	0.00199
70	0.3631	8.325	0.9989	0.00200
80	0.5069	8.314	0.9976	0.00200
90	0.6982	8.303	0.9963	0.00200
100	0.9492	8.289	0.9946	0.00201
110	1.2748	8.267	0.9919	0.00201
120	1.6924	8.253	0.9901	0.00201
130	2.2225	8.227	0.9872	0.00202
140	2.8886	8.207	0.9848	0.00203
150	3.718	8.182	0.9818	0.00203
160	4.741	8.156	0.9786	0.00204
170	5.992	8.127	0.9752	0.00205
180	7.510	8.098	0.9717	0.00205
190	9.339	8.068	0.9681	0.00206
200	11.526	8.039	0.9646	0.00207
210	14.123	8.005	0.9605	0.00208
212	14.696	7.996	0.9594	0.00208
220	17.186	7.972	0.9566	0.00209
240	24.969	7.901	0.9480	0.00210
260	35.429	7.822	0.9386	0.00211
280	49.203	7.746	0.9294	0.00215
300	67.013	7.662	0.9194	0.00217
350	134.63	7.432	0.8918	0.00224
400	247.31	7.172	0.8606	0.00232
450	422.6	6.892	0.8270	0.00241
500	680.8	6.553	0.7863	0.00254
550	1045.2	6.132	0.7358	0.00271
600	1542.9	5.664	0.6796	0.00294
700	3093.7	3.623	0.4347	0.00460

1. Multiply flow in pounds per hour by the factor to get equivalent flow in gallons per minute. Weight per gallon is based on 7.48 gallons per cubic foot.



## 12.7 Properties of Saturated Steam

Absolute Pressure		Vacuum (in Hg)	Temperature (°F)	Heat of the Liquid (BTU/lb)	Latent Heat of Evaporation (BTU/lb)	Total Heat of Steam (BTU/lb)	Specific Volume (ft <sup>3</sup> /lb)
lb/in <sup>2</sup>	in Hg						
0.20	0.41	29.51	53.14	21.21	1063.8	1085.0	1526.0
0.25	0.51	29.41	59.30	27.36	1060.3	1087.7	1235.3
0.30	0.61	29.31	64.47	32.52	1057.4	1090.0	1039.5
0.35	0.71	29.21	68.93	36.97	1054.9	1091.9	898.5
0.40	0.81	29.11	72.86	40.89	1052.7	1093.6	791.9
0.45	0.92	29.00	76.38	44.41	1050.7	1095.1	708.5
0.50	1.02	28.90	79.58	47.60	1048.8	1096.4	641.4
0.60	1.22	28.70	85.21	53.21	1045.7	1098.9	540.0
0.70	1.43	28.49	90.08	58.07	1042.9	1101.0	466.9
0.80	1.63	28.29	94.38	62.36	1040.4	1102.8	411.7
0.90	1.83	28.09	98.24	66.21	1038.3	1104.5	368.4
1.0	2.04	27.88	101.74	69.70	1036.3	1106.0	333.6
1.2	2.44	27.48	107.92	75.87	1032.7	1108.6	280.9
1.4	2.85	27.07	113.26	81.20	1029.6	1110.8	243.0
1.6	3.26	26.66	117.99	85.91	1026.9	1112.8	214.3
1.8	3.66	26.26	122.23	90.14	1024.5	1114.6	191.8
2.0	4.07	25.85	126.08	93.99	1022.2	1116.2	173.73
2.2	4.48	25.44	129.62	97.52	1020.2	1117.7	158.85
2.4	4.89	25.03	132.89	100.79	1018.3	1119.1	146.38
2.6	5.29	24.63	135.94	103.83	1016.5	1120.3	135.78
2.8	5.70	24.22	138.79	106.68	1014.8	1121.5	126.65
3.0	6.11	23.81	141.48	109.37	1013.2	1122.6	118.71
3.5	7.13	22.79	147.57	115.46	1009.6	1125.1	102.72
4.0	8.14	21.78	152.97	120.86	1006.4	1127.3	90.63
4.5	9.16	20.76	157.83	125.71	1003.6	1129.3	81.16
5.0	10.18	19.74	162.24	130.13	1001.0	1131.1	73.52
5.5	11.20	18.72	166.30	134.19	998.5	1132.7	67.24
6.0	12.22	17.70	170.06	137.96	996.2	1134.2	61.98
6.5	13.23	16.69	173.56	141.47	994.1	1135.6	57.50
7.0	14.25	15.67	176.85	144.76	992.1	1136.9	53.64
7.5	15.27	14.65	179.94	147.86	990.2	1138.1	50.29
8.0	16.29	13.63	182.86	150.79	988.5	1139.3	47.34
8.5	17.31	12.61	185.64	153.57	986.8	1140.4	44.73
9.0	18.32	11.60	188.28	156.22	985.2	1141.4	42.40

## 12 – Engineering Data

### 12.7 Properties of Saturated Steam, continued.

Absolute Pressure		Vacuum (in Hg)	Temperature (°F)	Heat of the Liquid (BTU/lb)	Latent Heat of Evaporation (BTU/lb)	Total Heat of Steam (BTU/lb)	Specific Volume (ft <sup>3</sup> /lb)
lb/in <sup>2</sup>	in Hg						
9.5	19.34	10.58	190.80	158.75	983.6	1142.3	40.31
10.0	20.36	9.56	193.21	161.17	982.1	1143.3	38.42
11.0	22.40	7.52	197.75	165.73	979.3	1145.0	35.14
12.0	24.43	5.49	201.96	169.96	976.6	1146.6	32.40
13.0	26.47	3.45	205.88	173.91	974.2	1148.1	30.06
14.0	28.50	1.42	209.56	177.61	971.9	1149.5	28.04

Pressure (lb/in <sup>2</sup> )		Temperature (°F)	Heat of the Liquid (BTU/lb)	Latent Heat of Evaporation (BTU/lb)	Total Heat of Steam (BTU/lb)	Specific Volume (ft <sup>3</sup> /lb)
Absolute	Gage					
14.696	0.0	212.00	180.07	970.3	1150.4	26.80
15.0	0.3	213.03	181.11	969.7	1150.8	26.29
16.0	1.3	216.32	184.42	967.6	1152.0	24.75
17.0	2.3	219.44	187.56	965.5	1153.1	23.39
18.0	3.3	222.41	190.56	963.6	1154.2	22.17
19.0	4.3	225.24	193.42	961.9	1155.3	21.08
20.0	5.3	227.96	196.16	960.1	1156.3	20.089
21.0	6.3	230.57	198.79	958.4	1157.2	19.192
22.0	7.3	233.07	201.33	956.8	1158.1	18.375
23.0	8.3	235.49	203.78	955.2	1159.0	17.627
24.0	9.3	237.82	206.14	953.7	1159.8	16.938
25.0	10.3	240.07	208.42	952.1	1160.6	16.303
26.0	11.3	242.25	210.62	950.7	1161.3	15.715
27.0	12.3	244.36	212.75	949.3	1162.0	15.170
28.0	13.3	246.41	214.83	947.9	1162.7	14.663
29.0	14.3	248.40	216.86	946.5	1163.4	14.189
30.0	15.3	250.33	218.82	945.3	1164.1	13.746
31.0	16.3	252.22	220.73	944.0	1164.7	13.330
32.0	17.3	254.05	222.59	942.8	1165.4	12.940
33.0	18.3	255.84	224.41	941.6	1166.0	12.572
34.0	19.3	257.58	226.18	940.3	1166.5	12.226
35.0	20.3	259.28	227.91	939.2	1167.1	11.898
36.0	21.3	260.95	229.60	938.0	1167.6	11.588
37.0	22.3	262.57	231.26	936.9	1168.2	11.294

### 12.7 Properties of Saturated Steam, continued.

Pressure (lb/in <sup>2</sup> )		Temperature (°F)	Heat of the Liquid (BTU/lb)	Latent Heat of Evaporation (BTU/lb)	Total Heat of Steam (BTU/lb)	Specific Volume (ft <sup>3</sup> /lb)
Absolute	Gage					
38.0	23.3	264.16	232.89	935.8	1168.7	11.015
39.0	24.3	265.72	234.48	934.7	1169.2	10.750
40.0	25.3	267.25	236.03	933.7	1169.7	10.498
41.0	26.3	268.74	237.55	932.6	1170.2	10.258
42.0	27.3	270.21	239.04	931.6	1170.7	10.029
43.0	28.3	271.64	240.51	930.6	1171.1	9.810
44.0	29.3	273.05	241.95	929.6	1171.6	9.601
45.0	30.3	274.44	243.36	928.6	1172.0	9.401
46.0	31.3	275.80	244.75	927.7	1172.4	9.209
47.0	32.3	277.13	246.12	926.7	1172.9	9.025
48.0	33.3	278.45	247.47	925.8	1173.3	8.848
49.0	34.3	279.74	248.79	924.9	1173.7	8.678
50.0	35.3	281.01	250.09	924.0	1174.1	8.515
51.0	36.3	282.26	251.37	923.0	1174.4	8.359
52.0	37.3	283.49	252.63	922.2	1174.8	8.208
53.0	38.3	284.70	253.87	921.3	1175.2	8.062
54.0	39.3	285.90	255.09	920.5	1175.6	7.922
55.0	40.3	287.07	256.30	919.6	1175.9	7.787
56.0	41.3	288.23	257.50	918.8	1176.3	7.656
57.0	42.3	289.37	258.67	917.9	1176.6	7.529
58.0	43.3	290.50	259.82	917.1	1176.9	7.407
59.0	44.3	291.61	260.96	916.3	1177.3	7.289
60.0	45.3	292.71	262.09	915.5	1177.6	7.175
61.0	46.3	293.79	263.20	914.7	1177.9	7.064
62.0	47.3	294.85	264.30	913.9	1178.2	6.957
63.0	48.3	295.90	265.38	913.1	1178.5	6.853
64.0	49.3	296.94	266.45	912.3	1178.8	6.752
65.0	50.3	297.97	267.50	911.6	1179.1	6.655
66.0	51.3	298.99	268.55	910.8	1179.4	6.560
67.0	52.3	299.99	269.58	910.1	1179.7	6.468
68.0	53.3	300.98	270.60	909.4	1180.0	6.378
69.0	54.3	301.96	291.61	908.7	1180.3	6.291
70.0	55.3	302.92	272.61	907.9	1180.6	6.206
71.0	56.3	303.88	273.60	907.2	1180.8	6.124

### 12.7 Properties of Saturated Steam, continued.

Pressure (lb/in <sup>2</sup> )		Temperature (°F)	Heat of the Liquid (BTU/lb)	Latent Heat of Evaporation (BTU/lb)	Total Heat of Steam (BTU/lb)	Specific Volume (ft <sup>3</sup> /lb)
Absolute	Gage					
72.0	57.3	304.83	274.57	906.5	1181.1	6.044
73.0	58.3	305.76	275.54	905.8	1181.3	5.966
74.0	59.3	306.68	276.49	905.1	1181.6	5.890
75.0	60.3	307.60	277.43	904.5	1181.9	5.816
76.0	61.3	308.50	278.37	903.7	1182.1	5.743
77.0	62.3	309.40	279.30	903.1	1182.4	5.673
78.0	63.3	310.29	280.21	902.4	1182.6	5.604
79.0	64.3	311.16	281.12	901.7	1182.8	5.537
80.0	65.3	312.03	282.02	901.1	1183.1	5.472
81.0	66.3	312.89	282.91	900.4	1183.3	5.408
82.0	67.3	313.74	283.79	899.7	1183.5	5.346
83.0	68.3	314.59	284.66	899.1	1183.8	5.285
84.0	69.3	315.42	285.53	898.5	1184.0	5.226
85.0	70.3	316.25	286.39	897.8	1184.2	5.168
86.0	71.3	317.07	287.24	897.2	1184.4	5.111
87.0	72.3	317.88	288.08	896.5	1184.6	5.055
88.0	73.3	318.68	288.91	895.9	1184.8	5.001
89.0	74.3	319.48	289.74	895.3	1185.1	4.948
90.0	75.3	320.27	290.56	894.7	1185.3	4.896
91.0	76.3	321.06	291.38	894.1	1185.5	4.845
92.0	77.3	321.83	292.18	893.5	1185.7	4.796
93.0	78.3	322.60	292.98	892.9	1185.9	4.747
94.0	79.3	323.36	293.78	892.3	1186.1	4.699
95.0	80.3	324.12	294.56	891.7	1186.2	4.652
96.0	81.3	324.87	295.34	891.1	1186.4	4.606
97.0	82.3	325.61	296.12	890.5	1186.6	4.561
98.0	83.3	326.35	296.89	889.9	1186.8	4.517
99.0	84.3	327.08	297.65	889.4	1187.0	4.474
100.0	85.3	327.81	298.40	888.8	1187.2	4.432
101.0	86.3	328.53	299.15	888.2	1187.4	4.391
102.0	87.3	329.25	299.90	887.6	1187.5	4.350
103.0	88.3	329.96	300.64	887.1	1187.7	4.310
104.0	89.3	330.66	301.37	886.5	1187.9	4.271
105.0	90.3	331.36	302.10	886.0	1188.1	4.232
106.0	91.3	332.05	302.82	885.4	1188.2	4.194

### 12.7 Properties of Saturated Steam, continued.

Pressure (lb/in <sup>2</sup> )		Temperature (°F)	Heat of the Liquid (BTU/lb)	Latent Heat of Evaporation (BTU/lb)	Total Heat of Steam (BTU/lb)	Specific Volume (ft <sup>3</sup> /lb)
Absolute	Gage					
107.0	92.3	332.74	303.54	884.9	1188.4	4.157
108.0	93.3	333.42	304.26	884.3	1188.6	4.120
109.0	94.3	334.10	304.97	883.7	1188.7	4.084
110.0	95.3	334.77	305.66	883.2	1188.9	4.049
111.0	96.3	335.44	306.37	882.6	1189.0	4.015
112.0	97.3	336.11	307.06	882.1	1189.2	3.981
113.0	98.3	336.77	307.75	881.6	1189.4	3.947
114.0	99.3	337.42	308.43	881.1	1189.5	3.914
115.0	100.3	338.07	309.11	880.6	1189.7	3.882
116.0	101.3	338.72	309.79	880.0	1189.8	3.850
117.0	102.3	339.36	310.46	879.5	1190.0	3.819
118.0	103.3	339.99	311.12	879.0	1190.1	3.788
119.0	104.3	340.62	311.78	878.4	1190.2	3.758
120.0	105.3	341.25	312.44	877.9	1190.4	3.728
121.0	106.3	341.88	313.10	877.4	1190.5	3.699
122.0	107.3	342.50	313.75	876.9	1190.7	3.670
123.0	108.3	343.11	314.40	876.4	1190.8	3.642
124.0	109.3	343.72	315.04	875.9	1190.9	3.614
125.0	110.3	344.33	315.68	875.4	1191.1	3.587
126.0	111.3	344.94	316.31	874.9	1191.2	3.560
127.0	112.3	345.54	316.94	874.4	1191.3	3.533
128.0	113.3	346.13	317.57	873.9	1191.5	3.507
129.0	114.3	346.73	318.19	873.4	1191.6	3.481
130.0	115.3	347.32	318.81	872.9	1191.7	3.455
131.0	116.3	347.90	319.43	872.5	1191.9	3.430
132.0	117.3	348.48	320.04	872.0	1192.0	3.405
133.0	118.3	349.06	320.65	871.5	1192.1	3.381
134.0	119.3	349.64	321.25	871.0	1192.2	3.357
135.0	120.3	350.21	321.85	870.6	1192.4	3.333
136.0	121.3	350.78	322.45	870.1	1192.5	3.310
137.0	122.3	351.35	323.05	869.6	1192.6	3.287
138.0	123.3	351.91	323.64	869.1	1192.7	3.264
139.0	124.3	352.47	324.23	868.7	1192.9	3.242
140.0	125.3	353.02	324.82	868.2	1193.0	3.220
141.0	126.3	353.57	325.40	867.7	1193.1	3.198

### 12.7 Properties of Saturated Steam, continued.

Pressure (lb/in <sup>2</sup> )		Temperature (°F)	Heat of the Liquid (BTU/lb)	Latent Heat of Evaporation (BTU/lb)	Total Heat of Steam (BTU/lb)	Specific Volume (ft <sup>3</sup> /lb)
Absolute	Gage					
142.0	127.3	354.12	325.98	867.2	1193.2	3.177
143.0	128.3	354.67	326.56	866.7	1193.3	3.155
144.0	129.3	355.21	327.13	866.3	1193.4	3.134
145.0	130.3	355.76	327.70	865.8	1193.5	3.114
146.0	131.3	356.29	328.27	865.3	1193.6	3.094
147.0	132.3	356.83	328.83	864.9	1193.8	3.074
148.0	133.3	357.36	329.39	864.5	1193.9	3.054
149.0	134.3	357.89	329.95	864.0	1194.0	3.034
150.0	135.3	358.42	330.51	863.6	1194.1	3.015
152.0	137.3	359.46	331.61	862.7	1194.3	2.977
154.0	139.3	360.49	332.70	861.8	1194.5	2.940
156.0	141.3	361.52	333.79	860.9	1194.7	2.904
158.0	143.3	362.53	334.86	860.0	1194.9	2.869
160.0	145.3	363.53	335.93	859.2	1195.1	2.834
162.0	147.3	364.53	336.98	858.3	1195.3	2.801
164.0	149.3	365.51	338.02	857.5	1195.5	2.768
166.0	151.3	366.48	339.05	856.6	1195.7	2.736
168.0	153.3	367.45	340.07	855.7	1195.8	2.705
170.0	155.3	368.41	341.09	854.9	1196.0	2.675
172.0	157.3	369.35	342.10	854.1	1196.2	2.645
174.0	159.3	370.29	343.10	853.3	1196.4	2.616
176.0	161.3	371.22	344.09	852.4	1196.5	2.587
178.0	163.3	372.14	345.06	851.6	1196.7	2.559
180.0	165.3	373.06	346.03	850.8	1196.9	2.532
182.0	167.3	373.96	347.00	850.0	1197.0	2.505
184.0	169.3	374.86	347.96	849.2	1197.2	2.479
186.0	171.3	375.75	348.92	848.4	1197.3	2.454
188.0	173.3	376.64	349.86	847.6	1197.5	2.429
190.0	175.3	377.51	350.79	846.8	1197.6	2.404
192.0	177.3	378.38	351.72	846.1	1197.8	2.380
194.0	179.3	379.24	352.64	845.3	1197.9	2.356
196.0	181.3	380.10	353.55	844.5	1198.1	2.333
198.0	183.3	380.95	354.46	843.7	1198.2	2.310
200.0	185.3	381.79	355.36	843.0	1198.4	2.288

### 12.7 Properties of Saturated Steam, continued.

Pressure (lb/in <sup>2</sup> )		Temperature (°F)	Heat of the Liquid (BTU/lb)	Latent Heat of Evaporation (BTU/lb)	Total Heat of Steam (BTU/lb)	Specific Volume (ft <sup>3</sup> /lb)
Absolute	Gage					
205.0	190.3	383.86	357.58	841.1	1198.7	2.234
210.0	195.3	385.90	359.77	839.2	1199.0	2.183
215.0	200.3	387.89	361.91	837.4	1199.3	2.134
220.0	205.3	389.86	364.02	835.6	1199.6	2.087
225.0	210.3	391.79	366.09	833.8	1199.9	2.0422
230.0	215.3	393.68	368.13	832.0	1200.1	1.9992
235.0	220.3	395.54	370.14	830.3	1200.4	1.9579
240.0	225.3	397.37	372.12	828.5	1200.6	1.9183
245.0	230.3	399.18	374.08	826.8	1200.9	1.8803
250.0	235.3	400.95	376.00	825.1	1201.1	1.8438
255.0	240.3	402.70	377.89	823.4	1201.3	1.8086
260.0	245.3	404.42	379.76	821.8	1201.5	1.7748
265.0	250.3	406.11	381.60	820.1	1201.7	1.7422
270.0	255.3	407.78	383.42	818.5	1201.9	1.7107
275.0	260.3	409.43	385.21	816.9	1202.1	1.6804
280.0	265.3	411.05	386.98	815.3	1202.3	1.6511
285.0	270.3	412.65	388.73	813.7	1202.4	1.6228
290.0	275.3	414.23	390.46	812.1	1202.6	1.5954
295.0	280.3	415.79	392.16	810.5	1202.7	1.5689
300.0	285.3	417.33	393.84	809.0	1202.8	1.5433
320.0	305.3	423.29	400.39	803.0	1203.4	1.4485
340.0	325.3	428.97	406.66	797.1	1203.7	1.3645
360.0	345.3	434.40	412.67	791.4	1204.1	1.2895
380.0	365.3	439.60	418.45	785.8	1204.3	1.2222
400.0	385.3	444.59	424.0	780.5	1204.5	1.1613
420.0	405.3	449.39	429.4	775.2	1204.6	1.1061
440.0	425.3	454.02	434.6	770.0	1204.6	1.0556
460.0	445.3	458.50	439.7	764.9	1204.6	1.0094
480.0	465.3	462.82	444.6	759.9	1204.5	0.9670
500.0	485.3	467.01	449.4	755.0	1204.4	0.9278
520.0	505.3	471.07	454.1	750.1	1204.2	0.8915
540.0	525.3	475.01	458.6	745.4	1204.0	0.8578
560.0	545.3	478.85	463.0	740.8	1203.8	0.8265
580.0	565.3	482.58	467.4	736.1	1203.5	0.7973

### 12.7 Properties of Saturated Steam, continued.

Pressure (lb/in <sup>2</sup> )		Temperature (°F)	Heat of the Liquid (BTU/lb)	Latent Heat of Evaporation (BTU/lb)	Total Heat of Steam (BTU/lb)	Specific Volume (ft <sup>3</sup> /lb)
Absolute	Gage					
600.0	585.3	486.21	471.6	731.6	1203.2	0.7698
620.0	605.3	489.75	475.7	727.2	1202.9	0.7440
640.0	625.3	493.21	479.8	722.7	1202.5	0.7198
660.0	645.3	496.58	483.8	718.3	1202.1	0.6971
680.0	665.3	499.88	487.7	714.0	1201.7	0.6757
700.0	685.3	503.10	491.5	709.7	1201.2	0.6554
720.0	705.3	506.25	495.3	705.4	1200.7	0.6362
740.0	725.3	509.34	499.0	701.2	1200.2	0.6180
760.0	745.3	512.36	502.6	697.1	1199.7	0.6007
780.0	765.3	515.33	506.2	692.9	1199.1	0.5843
800.0	785.3	518.23	509.7	688.9	1198.6	0.5687
820.0	805.3	521.08	513.2	684.8	1198.0	0.5538
840.0	825.3	523.88	516.6	680.8	1197.4	0.5396
860.0	845.3	526.63	520.0	676.8	1196.8	0.5260
880.0	865.3	529.33	523.3	672.8	1196.1	0.5130
900.0	885.3	531.98	526.6	668.8	1195.4	0.5006
920.0	905.3	534.59	529.8	664.9	1194.7	0.4886
940.0	925.3	537.16	533.0	661.0	1194.0	0.4772
960.0	945.3	539.68	536.2	657.1	1193.3	0.4663
980.0	965.3	542.17	539.3	653.3	1192.6	0.4557
1000.0	985.3	544.61	542.4	649.4	1191.8	0.4456
1050.0	1035.3	550.57	550.0	639.9	1189.9	0.4218
1100.0	1085.3	556.31	557.4	630.4	1187.8	0.4001
1150.0	1135.3	561.86	564.6	621.0	1185.6	0.3802
1200.0	1185.3	567.22	571.7	611.7	1183.4	0.3619
1250.0	1235.3	572.42	578.6	602.4	1181.0	0.3450
1300.0	1285.3	577.46	585.4	593.2	1178.6	0.3293
1350.0	1335.3	582.35	592.1	584.0	1176.1	0.3148
1400.0	1385.3	587.10	598.7	574.7	1173.4	0.3012
1450.0	1435.3	591.73	605.2	565.5	1170.7	0.2884
1500.0	1485.3	596.23	611.6	556.3	1167.9	0.2765
1600.0	1585.3	604.90	624.1	538.0	1162.1	0.2548
1700.0	1685.3	613.15	636.3	519.6	1155.9	0.2354
1800.0	1785.3	621.03	648.3	501.1	1149.4	0.2179



### 12.7 Properties of Saturated Steam, continued.

Pressure (lb/in <sup>2</sup> )		Temperature (°F)	Heat of the Liquid (BTU/lb)	Latent Heat of Evaporation (BTU/lb)	Total Heat of Steam (BTU/lb)	Specific Volume (ft <sup>3</sup> /lb)
Absolute	Gage					
1900.0	1885.3	628.58	660.1	482.4	1142.4	0.2021
2000.0	1985.3	635.82	671.7	463.4	1135.1	0.1878
2100.0	2085.3	642.77	683.3	444.1	1127.4	0.1746
2200.0	2185.3	649.46	694.8	424.4	1119.2	0.1625
2300.0	2285.3	655.91	706.5	403.9	1110.4	0.1513
2400.0	2385.3	662.12	718.4	382.7	1101.1	0.1407
2500.0	2485.3	668.13	730.6	360.5	1091.1	0.1307
2600.0	2585.3	673.94	743.0	337.2	1080.2	0.1213
2700.0	2685.3	679.55	756.2	312.1	1068.3	0.1123
2800.0	2785.3	684.99	770.1	284.7	1054.8	0.1035
2900.0	2885.3	690.26	785.4	253.6	1039.0	0.0947
3000.0	2985.3	695.36	802.5	217.8	1020.3	0.0858
3100.0	3085.3	700.31	825.0	168.1	993.1	0.0753
3200.0	3185.3	705.11	872.4	62.0	934.4	0.0580
3206.2	3191.5	705.40	902.7	0.0	902.7	0.0503

## 12.8 Properties of Superheated Steam

$v_f$  = specific volume, ft<sup>3</sup>/lb<sub>m</sub>;  $h_v$  = Enthalpy, BTU/lb

Pressure (psi)		Saturated Temperature (°F)	$v_f$ , $h_v$	Temperature (°F)					
Absolute	Gage			360	400	440	480	500	600
14.696	0.0	212.00	$v_f$ $h_v$	33.03 1221.1	34.68 1239.9	36.32 1258.8	37.96 1277.6	38.78 1287.1	42.86 1334.8
20.0	5.3	227.96	$v_f$ $h_v$	24.21 1220.3	25.43 1239.2	26.65 1258.2	27.86 1277.1	28.46 1286.6	31.47 1334.4
30.0	15.3	250.33	$v_f$ $h_v$	16.072 1218.6	16.897 1237.9	17.714 1257.0	18.528 1276.2	18.933 1285.7	20.95 1333.8
40.0	25.3	267.25	$v_f$ $h_v$	12.001 1216.9	12.628 1236.5	13.247 1255.9	13.862 1275.2	14.168 1284.8	15.688 1333.1
50.0	35.3	281.01	$v_f$ $h_v$	9.557 1215.2	10.065 1235.1	10.567 1254.7	11.062 1274.2	11.309 1283.9	12.532 1332.5

Pressure (psi)		Saturated Temperature (°F)	$v_f$ , $h_v$	Temperature (°F)				
Absolute	Gage			700	800	900	1000	1200
14.696	0.0	212.00	$v_f$ $h_v$	46.94 1383.2	51.00 1432.3	55.07 1482.3	59.13 1533.1	67.25 1637.5
20.0	5.3	227.96	$v_f$ $h_v$	34.47 1382.9	37.46 1432.1	40.45 1482.1	43.44 1533.0	49.41 1637.4
30.0	15.3	250.33	$v_f$ $h_v$	22.96 1382.4	24.96 1431.7	26.95 1481.8	28.95 1532.7	32.93 1637.2
40.0	25.3	267.25	$v_f$ $h_v$	17.198 1381.9	18.702 1431.3	20.20 1481.4	21.70 1532.4	24.69 1637.0
50.0	35.3	281.01	$v_f$ $h_v$	13.744 1381.4	14.950 1430.9	16.152 1481.1	17.352 1532.1	19.747 1636.8

## 12.8 Properties of Superheated Steam, continued.

Pressure (psi)		Saturated Temperature (°F)	$v_f$ $h_v$	Temperature (°F)					
Absolute	Gage			360	400	440	480	500	600
60.0	45.3	292.71	$v_f$ $h_v$	7.927 1213.4	8.357 1233.	8.779 1253.5	9.196 1273.2	9.403 1283.0	10.427 1331.8
70.0	55.3	302.92	$v_f$ $h_v$	6.762 1211.5	7.136 1232.1	7.502 1252.3	7.863 1272.2	8.041 1282.0	8.924 1331.1
80.0	65.3	312.03	$v_f$ $h_v$	5.888 1209.7	6.220 1230.7	6.544 1251.1	6.862 1271.1	7.020 1281.1	7.797 1330.5
90.0	75.3	320.27	$v_f$ $h_v$	5.208 1207.7	5.508 1229.1	5.799 1249.8	6.084 1270.1	6.225 1280.1	6.920 1329.8
100.0	85.3	327.81	$v_f$ $h_v$	4.663 1205.7	4.937 1227.6	5.202 1248.6	5.462 1269.0	5.589 1279.1	6.218 1329.1
120.0	105.3	341.25	$v_f$ $h_v$	3.844 1201.6	4.081 1224.4	4.307 1246.0	4.527 1266.90	4.636 1277.2	5.165 1327.7
140.0	125.3	353.02	$v_f$ $h_v$	3.258 1197.3	3.468 1221.1	3.667 1243.3	3.860 1264.7	3.954 1275.2	4.413 1326.4
160.0	145.3	363.53	$v_f$ $h_v$	– –	3.008 1217.6	3.187 1240.6	3.359 1262.4	3.443 1273.1	3.849 1325.0
180.0	165.3	373.06	$v_f$ $h_v$	– –	2.649 1214.0	2.813 1237.8	2.969 1260.2	3.044 1271.0	3.411 1323.5

Pressure (psi)		Saturated Temperature (°F)	$v_f$ $h_v$	Temperature (°F)				
Absolute	Gage			700	800	900	1000	1200
60.0	45.3	292.71	$v_f$ $h_v$	11.441 1380.9	12.449 1430.5	13.452 1480.8	14.454 1531.9	16.451 1636.6
70.0	55.3	302.92	$v_f$ $h_v$	9.796 1380.4	10.662 1430.1	11.524 1480.5	12.383 1531.6	14.097 1636.3
80.0	65.3	312.03	$v_f$ $h_v$	8.562 1379.9	9.322 1429.7	10.077 1480.1	10.830 1531.3	12.332 1636.2
90.0	75.3	320.27	$v_f$ $h_v$	7.603 1379.4	8.279 1429.3	8.952 1479.8	9.623 1531.0	10.959 1635.9
100.0	85.3	327.81	$v_f$ $h_v$	6.835 1378.9	7.446 1428.9	8.052 1479.5	8.656 1530.8	9.860 1635.7
120.0	105.3	341.25	$v_f$ $h_v$	5.683 1377.8	6.195 1428.1	6.702 1478.8	7.207 1530.2	8.212 1635.3
140.0	125.3	353.02	$v_f$ $h_v$	4.861 1376.8	5.301 1427.3	5.738 1478.2	6.172 1529.7	7.035 1634.9
160.0	145.3	363.53	$v_f$ $h_v$	4.244 1375.7	4.631 1426.4	5.015 1477.5	5.396 1529.1	6.152 1634.5
180.0	165.3	373.06	$v_f$ $h_v$	3.764 1374.7	4.110 1425.6	4.452 1476.8	4.792 1528.6	5.466 1634.1

### 12.8 Properties of Superheated Steam, continued.

Pressure (psi)		Saturated Temperature (°F)	$v_f$ , $h_v$	Temperature (°F)					
Absolute	Gage			360	400	440	480	500	600
200.0	185.3	381.79	$v_f$ $h_v$	– –	2.361 1210.3	2.513 1234.9	2.656 1257.8	2.726 1268.9	3.060 1322.1
220.0	205.3	389.86	$v_f$ $h_v$	– –	2.125 1206.5	2.267 1231.9	2.400 1255.4	2.465 1266.7	2.772 1320.7
240.0	225.3	397.37	$v_f$ $h_v$	– –	1.9276 1202.5	2.062 1228.8	2.187 1253.0	2.247 1264.5	2.533 1319.2
260.0	245.3	404.42	$v_f$ $h_v$	– –	– –	1.8882 1225.7	2.006 1250.5	2.063 1262.3	2.330 1317.7
280.0	265.3	411.05	$v_f$ $h_v$	– –	– –	1.7388 1222.4	1.8512 1247.9	1.9047 1260.0	2.156 1316.2
300.0	285.3	417.33	$v_f$ $h_v$	– –	– –	1.6090 1219.1	1.7165 1245.3	1.7675 1257.6	2.005 1314.7
320.0	305.3	423.29	$v_f$ $h_v$	– –	– –	1.4950 1215.6	1.5985 1242.6	1.6472 1255.2	1.8734 1313.2
340.0	325.3	428.97	$v_f$ $h_v$	– –	– –	1.3941 1212.1	1.4941 1239.9	1.5410 1252.8	1.7569 1311.6
360.0	345.3	434.40	$v_f$ $h_v$	– –	– –	1.3041 1208.4	1.4012 1237.1	1.4464 1250.3	1.6533 1310.1

Pressure (psi)		Saturated Temperature (°F)	$v_f$ , $h_v$	Temperature (°F)				
Absolute	Gage			700	800	900	1000	1200
200.0	185.3	381.79	$v_f$ $h_v$	3.380 1373.6	3.693 1424.8	4.002 1476.2	4.309 1528.0	4.917 1633.7
220.0	205.3	389.86	$v_f$ $h_v$	3.066 1372.6	3.352 1424.0	3.634 1475.5	3.913 1527.5	4.467 1633.3
240.0	225.3	397.37	$v_f$ $h_v$	2.804 1371.5	3.068 1423.2	3.327 1474.8	3.584 1526.9	4.093 1632.9
260.0	245.3	404.42	$v_f$ $h_v$	2.582 1370.4	2.827 1422.3	3.067 1474.2	3.305 1526.3	3.776 1632.5
280.0	265.3	411.05	$v_f$ $h_v$	2.392 1369.4	2.621 1421.5	2.845 1473.5	3.066 1525.8	3.504 1632.1
300.0	285.3	417.33	$v_f$ $h_v$	2.227 1368.3	2.442 1420.6	2.652 1472.8	2.859 1525.2	3.269 1631.7
320.0	305.3	423.29	$v_f$ $h_v$	2.083 1367.2	2.285 1419.8	2.483 1472.1	2.678 1524.7	3.063 1631.3
340.0	325.3	428.97	$v_f$ $h_v$	1.9562 1366.1	2.147 1419.0	2.334 1471.5	2.518 1524.1	2.881 1630.9
360.0	345.3	434.40	$v_f$ $h_v$	1.8431 1365.0	2.025 1418.1	2.202 1470.8	2.376 1523.5	2.719 1630.5

## 12.8 Properties of Superheated Steam, continued.

Pressure (psi)		Saturated Temperature (°F)	$v_f, h_v$	Temperature (°F)					
Absolute	Gage			500	540	600	640	660	700
380.0	365.3	439.60	$v_f$ $h_v$	1.3616 1247.7	1.444 1273.1	1.5605 1308.5	1.6345 1331.0	1.6707 1342.0	1.7419 1363.8
400.0	385.3	444.59	$v_f$ $h_v$	1.2851 1245.1	1.3652 1271.0	1.4770 1306.9	1.5480 1329.6	1.5827 1340.8	1.6508 1362.7
420.0	405.3	449.39	$v_f$ $h_v$	1.2158 1242.5	1.2935 1268.9	1.4014 1305.3	1.4697 1328.3	1.5030 1339.5	1.5684 1361.6
440.0	425.3	454.02	$v_f$ $h_v$	1.1526 1239.8	1.2282 1266.7	1.3327 1303.6	1.3984 1326.9	1.4306 1338.2	1.4934 1360.4
460.0	445.3	458.50	$v_f$ $h_v$	1.0948 1237.0	1.1685 1264.5	1.2698 1302.0	1.3334 1325.4	1.3644 1336.9	1.4250 1359.3
480.0	465.3	462.82	$v_f$ $h_v$	1.0417 1234.2	1.1138 1262.3	1.2122 1300.3	1.2737 1324.0	1.3038 1335.6	1.3622 1358.2
500.0	485.3	467.01	$v_f$ $h_v$	0.9927 1231.3	1.0633 1260.0	1.1591 1298.6	1.2188 1322.6	1.2478 1334.2	1.3044 1357.0
520.0	505.3	471.07	$v_f$ $h_v$	0.9473 1228.3	1.0166 1257.7	1.1101 1296.9	1.1681 1321.1	1.1962 1332.9	1.2511 1355.8
540.0	525.3	475.01	$v_f$ $h_v$	0.9052 1225.3	0.9733 1255.4	1.0646 1295.2	1.1211 1319.7	1.1485 1331.5	1.2017 1354.6

Pressure (psi)		Saturated Temperature (°F)	$v_f, h_v$	Temperature (°F)				
Absolute	Gage			740	800	900	1000	1200
380.0	365.3	439.60	$v_f$ $h_v$	1.8118 1385.3	1.9149 1417.3	2.083 1470.1	2.249 1523.0	2.575 1630.0
400.0	385.3	444.59	$v_f$ $h_v$	1.7177 1384.3	1.8161 1416.4	1.9767 1469.4	2.134 1522.4	2.445 1629.6
420.0	405.3	449.39	$v_f$ $h_v$	1.6324 1383.3	1.7267 1415.5	1.8802 1468.7	2.031 1521.9	2.327 1629.2
440.0	425.3	454.02	$v_f$ $h_v$	1.5549 1382.3	1.6454 1414.7	1.7925 1468.1	1.9368 1521.3	2.220 1628.8
460.0	445.3	458.50	$v_f$ $h_v$	1.4842 1381.3	1.5711 1413.8	1.7124 1467.4	1.8508 1520.7	2.122 1628.4
480.0	465.3	462.82	$v_f$ $h_v$	1.4193 1380.3	1.5031 1412.9	1.6390 1466.7	1.7720 1520.2	2.033 1628.0
500.0	485.3	467.01	$v_f$ $h_v$	1.3596 1379.3	1.4405 1412.1	1.5715 1466.0	1.6996 1519.6	1.9504 1627.6
520.0	505.3	471.07	$v_f$ $h_v$	1.3045 1378.2	1.3826 1411.2	1.5091 1465.3	1.6326 1519.0	1.8743 1627.2
540.0	525.3	475.01	$v_f$ $h_v$	1.2535 1377.2	1.3291 1410.3	1.4514 1464.6	1.5707 1518.5	1.8039 1626.8

### 12.8 Properties of Superheated Steam, continued.

Pressure (psi)		Saturated Temperature (°F)	$v_f, h_o$	Temperature (°F)					
Absolute	Gage			500	540	600	640	660	700
560.0	545.3	478.85	$v_f$ $h_o$	0.8659 1222.2	0.9330 1253.0	1.0224 1293.4	1.0775 1318.2	1.1041 1330.2	1.1558 1353.5
580.0	565.3	482.58	$v_f$ $h_o$	0.8291 1219.0	0.8954 1250.5	0.9830 1291.7	1.0368 1316.7	1.0627 1328.8	1.1331 1352.3
600.0	585.3	486.21	$v_f$ $h_o$	0.7947 1215.7	0.8602 1248.1	0.9463 1289.9	0.9988 1315.2	1.0241 1327.4	1.0732 1351.1
620.0	605.3	489.75	$v_f$ $h_o$	0.7624 1212.4	0.8272 1245.5	0.9118 1288.1	0.9633 1313.7	0.9880 1326.0	1.0358 1349.9
640.0	625.3	493.21	$v_f$ $h_o$	0.7319 1209.0	0.7963 1243.0	0.8795 1286.2	0.9299 1312.2	0.9541 1324.6	1.0008 1348.6
660.0	645.3	496.58	$v_f$ $h_o$	0.7032 1205.4	0.7670 1240.4	0.8491 1284.4	0.8985 1310.6	0.9222 1323.2	0.9679 1347.4
680.0	665.3	499.88	$v_f$ $h_o$	0.6759 1201.8	0.7395 1237.7	0.8205 1282.5	0.8690 1309.1	0.8922 1321.7	0.9369 1346.2
700.0	685.3	503.10	$v_f$ $h_o$	– –	0.7134 1235.0	0.7934 1280.6	0.8411 1307.5	0.8639 1320.3	0.9077 1345.0
750.0	735.3	510.86	$v_f$ $h_o$	– –	0.6540 1227.9	0.7319 1275.7	0.7778 1303.5	0.7996 1316.6	0.8414 1341.8

Pressure (psi)		Saturated Temperature (°F)	$v_f, h_o$	Temperature (°F)				
Absolute	Gage			740	800	900	1000	1200
560.0	545.3	478.85	$v_f$ $h_o$	1.2060 1376.1	1.2794 1409.4	1.3978 1463.9	1.5132 1517.9	1.7385 1626.4
580.0	565.3	482.58	$v_f$ $h_o$	1.1619 1375.1	1.2331 1408.6	1.3479 1463.2	1.4596 1517.3	1.6776 1626.0
600.0	585.3	486.21	$v_f$ $h_o$	1.1207 1374.0	1.1899 1407.7	1.3013 1462.5	1.4096 1516.7	1.6208 1625.5
620.0	605.3	489.75	$v_f$ $h_o$	1.0821 1373.0	1.1494 1406.8	1.2577 1461.8	1.3628 1516.2	1.5676 1625.1
640.0	625.3	493.21	$v_f$ $h_o$	1.0459 1371.9	1.1115 1405.9	1.2168 1461.1	1.3190 1515.6	1.5178 1624.7
660.0	645.3	496.58	$v_f$ $h_o$	1.0119 1370.8	1.0759 1405.0	1.1784 1460.4	1.2778 1515.0	1.4709 1624.3
680.0	665.3	499.88	$v_f$ $h_o$	0.9800 1369.8	1.0424 1404.1	1.1423 1459.7	1.2390 1514.5	1.4269 1623.9
700.0	685.3	503.10	$v_f$ $h_o$	0.9498 1368.7	1.0108 1403.2	1.1082 1459.0	1.2024 1513.9	1.3853 1623.5
750.0	735.3	510.86	$v_f$ $h_o$	0.8813 1366.0	0.9391 1400.9	1.0310 1457.2	1.1196 1512.4	1.2912 1622.4

### 12.8 Properties of Superheated Steam, continued.

Pressure (psi)		Saturated Temperature (°F)	$v_f, h_v$	Temperature (°F)					
Absolute	Gage			500	540	600	640	660	700
800.0	785.3	518.23	$v_f, h_v$	– –	0.6015 1220.5	0.6779 1270.7	0.7223 1299.4	0.7433 1312.9	0.7833 1338.6
850.0	835.3	525.26	$v_f, h_v$	– –	0.5546 1212.7	0.6301 1265.5	0.6732 1295.2	0.6934 1309.0	0.7320 1335.4
900.0	885.3	531.98	$v_f, h_v$	– –	0.5124 1204.4	0.5873 1260.1	0.6294 1290.9	0.6491 1305.1	0.6863 1332.1
950.0	935.3	538.42	$v_f, h_v$	– –	0.4740 1195.5	0.5489 1254.6	0.5901 1286.4	0.6092 1301.1	0.6453 1328.7
1000.0	985.3	544.61	$v_f, h_v$	– –	– –	0.5140 1248.8	0.5546 1281.9	0.5733 1297.0	0.6084 1325.3

Pressure (psi)		Saturated Temperature (°F)	$v_f, h_v$	Temperature (°F)				
Absolute	Gage			740	800	900	1000	1200
800.0	785.3	518.23	$v_f, h_v$	0.8215 1363.2	0.8763 1398.6	0.9633 1455.4	1.0470 1511.0	1.2088 1621.4
850.0	835.3	525.26	$v_f, h_v$	0.7685 1360.4	0.8209 1396.3	0.9037 1453.6	0.9830 1509.5	1.1360 1620.4
900.0	885.3	531.98	$v_f, h_v$	0.7215 1357.5	0.7716 1393.9	0.8506 1451.8	0.9262 1508.1	1.0714 1619.3
950.0	935.3	538.42	$v_f, h_v$	0.6793 1354.7	0.7275 1391.6	0.8031 1450.0	0.8753 1506.6	1.0136 1618.3
1000.0	985.3	544.61	$v_f, h_v$	0.6413 1351.7	0.6878 1389.2	0.7604 1448.2	0.8294 1505.1	0.9615 1617.3

### 12.8 Properties of Superheated Steam, continued.

Pressure (psi)		Saturated Temperature (°F)	$v_f, h_o$	Temperature (°F)					
Absolute	Gage			660	700	740	760	780	800
1100.0	1085.3	556.31	$v_f$ $h_o$	0.5110 1288.5	0.5445 1318.3	0.5755 1345.8	0.5904 1358.9	0.6049 1371.7	0.6191 1384.3
1200.0	1185.3	567.22	$v_f$ $h_o$	0.4586 1279.6	0.4909 1311.0	0.5206 1339.6	0.5347 1353.2	0.5484 1366.4	0.5617 1379.3
1300.0	1285.3	577.46	$v_f$ $h_o$	0.4139 1270.2	0.4454 1303.4	0.4739 1333.3	0.4874 1347.3	0.5004 1361.0	0.5131 1374.3
1400.0	1385.3	587.10	$v_f$ $h_o$	0.3753 1260.3	0.4062 1295.5	0.4338 1326.7	0.4468 1341.3	0.4593 1355.4	0.4714 1369.1
1500.0	1485.3	596.23	$v_f$ $h_o$	0.3413 1249.8	0.3719 1287.2	0.3989 1320.0	0.4114 1335.2	0.4235 1349.7	0.4352 1363.8
1600.0	1585.3	604.90	$v_f$ $h_o$	0.3112 1238.7	0.3417 1278.7	0.3682 1313.0	0.3804 1328.8	0.3921 1343.9	0.4034 1358.4
1700.0	1685.3	613.15	$v_f$ $h_o$	0.2842 1226.8	0.3148 1269.7	0.3410 1305.8	0.3529 1322.3	0.3643 1337.9	0.3753 1352.9
1800.0	1785.3	621.03	$v_f$ $h_o$	0.2597 1214.0	0.2907 1260.3	0.3166 1298.4	0.3284 1315.5	0.3395 1331.8	0.3502 1347.2
1900.0	1885.3	628.58	$v_f$ $h_o$	0.2371 1200.2	0.2688 1250.4	0.2947 1290.6	0.3063 1308.6	0.3173 1325.4	0.3277 1341.5

Pressure (psi)		Saturated Temperature (°F)	$v_f, h_o$	Temperature (°F)				
Absolute	Gage			860	900	1000	1100	1200
1100.0	1085.3	556.31	$v_f$ $h_o$	0.6601 1420.8	0.6866 1444.5	0.7503 1502.2	0.8177 1558.8	0.8716 1615.2
1200.0	1185.3	567.22	$v_f$ $h_o$	0.6003 1416.7	0.6250 1440.7	0.6843 1499.2	0.7412 1556.4	0.7967 1613.1
1300.0	1285.3	577.46	$v_f$ $h_o$	0.5496 1412.5	0.5728 1437.0	0.6284 1496.2	0.6816 1553.9	0.7333 1611.0
1400.0	1385.3	587.10	$v_f$ $h_o$	0.5061 1408.2	0.5281 1433.1	0.5805 1493.2	0.6305 1551.4	0.6789 1608.9
1500.0	1485.3	596.23	$v_f$ $h_o$	0.4684 1403.9	0.4893 1429.3	0.5390 1490.1	0.5862 1548.9	0.6318 1606.8
1600.0	1585.3	604.90	$v_f$ $h_o$	0.4353 1399.5	0.4553 1425.3	0.5027 1487.0	0.5474 1546.4	0.5906 1604.6
1700.0	1685.3	613.15	$v_f$ $h_o$	0.4061 1395.0	0.4253 1421.4	0.4706 1484.0	0.5132 1543.8	0.5542 1602.5
1800.0	1785.3	621.03	$v_f$ $h_o$	0.3801 1390.4	0.3986 1417.4	0.4421 1480.8	0.4828 1541.3	0.5218 1600.4
1900.0	1885.3	628.58	$v_f$ $h_o$	0.3568 1385.8	0.3747 1413.3	0.4165 1477.7	0.4556 1538.8	0.4929 1598.2



### 12.8 Properties of Superheated Steam, continued.

Pressure (psi)		Saturated Temperature (°F)	$v_f, h_v$	Temperature (°F)					
Absolute	Gage			660	700	740	760	780	800
2000.0	1985.3	635.82	$v_f$ $h_v$	0.2161 1184.9	0.2489 1240.0	0.2748 1282.6	0.2863 1301.4	0.2972 1319.0	0.3074 1335.5
2100.0	2085.3	642.77	$v_f$ $h_v$	0.1962 1167.7	0.2306 1229.0	0.2567 1274.3	0.2682 1294.0	0.2789 1312.3	0.2890 1329.5
2200.0	2185.3	649.46	$v_f$ $h_v$	0.1768 1147.8	0.2135 1217.4	0.2400 1265.7	0.2514 1286.3	0.2621 1305.4	0.2721 1323.3
2300.0	2285.3	655.91	$v_f$ $h_v$	0.1575 1123.8	0.1978 1204.9	0.2247 1256.7	0.2362 1278.4	0.2468 1298.4	0.2567 1316.9
2400.0	2385.3	662.12	$v_f$ $h_v$	– –	0.1828 1191.5	0.2105 1247.3	0.2221 1270.2	0.2327 1291.1	0.2425 1310.3
2500.0	2485.3	668.13	$v_f$ $h_v$	– –	0.1686 1176.8	0.1973 1237.6	0.2090 1261.8	0.2196 1283.6	0.2294 1303.6
2600.0	2585.3	673.94	$v_f$ $h_v$	– –	0.1549 1160.6	0.1849 1227.3	0.1967 1252.9	0.2074 1275.8	0.2172 1296.8
2700.0	2685.3	679.55	$v_f$ $h_v$	– –	0.1415 1142.5	0.1732 1216.5	0.1853 1243.8	0.1960 1267.9	0.2059 1289.7
2800.0	2785.3	684.99	$v_f$ $h_v$	– –	0.1281 1121.4	0.1622 1205.1	0.1745 1234.2	0.1854 1259.6	0.1953 1282.4

Pressure (psi)		Saturated Temperature (°F)	$v_f, h_v$	Temperature (°F)				
Absolute	Gage			860	900	1000	1100	1200
2000.0	1985.3	635.82	$v_f$ $h_v$	0.3358 1381.2	0.3532 1409.2	0.3935 1474.5	0.4311 1536.2	0.4668 1596.1
2100.0	2085.3	642.77	$v_f$ $h_v$	0.3167 1376.4	0.3337 1405.0	0.3727 1471.4	0.4089 1533.6	0.4433 1593.9
2200.0	2185.3	649.46	$v_f$ $h_v$	0.2994 1371.5	0.3159 1400.8	0.3538 1468.2	0.3837 1531.1	0.4218 1591.8
2300.0	2285.3	655.91	$v_f$ $h_v$	0.2835 1366.6	0.2997 1396.5	0.3365 1464.9	0.3703 1528.5	0.4023 1589.6
2400.0	2385.3	662.12	$v_f$ $h_v$	0.2689 1361.6	0.2848 1392.2	0.3207 1461.7	0.3534 1525.9	0.3843 1587.4
2500.0	2485.3	668.13	$v_f$ $h_v$	0.2555 1356.5	0.2710 1387.8	0.3061 1458.4	0.3379 1523.2	0.3678 1585.3
2600.0	2585.3	673.94	$v_f$ $h_v$	0.2431 1351.4	0.2584 1383.4	0.2926 1455.1	0.3236 1520.6	0.3526 1583.1
2700.0	2685.3	679.55	$v_f$ $h_v$	0.2315 1346.1	0.2466 1378.9	0.2801 1451.8	0.3103 1518.0	0.3385 1580.9
2800.0	2785.3	684.99	$v_f$ $h_v$	0.2208 1340.8	0.2356 1374.3	0.2685 1448.5	0.2979 1515.4	0.3254 1578.7

### 12.8 Properties of Superheated Steam, continued.

Pressure (psi)		Saturated Temperature (°F)	$v_f, h_o$	Temperature (°F)					
Absolute	Gage			660	700	740	760	780	800
2900.0	2885.3	690.26	$v_f$ $h_o$	– –	0.1143 1095.9	0.1517 1193.0	0.1644 1224.3	0.1754 1251.1	0.1853 1274.9
3000.0	2985.3	695.36	$v_f$ $h_o$	– –	0.0984 1060.7	0.1416 1180.1	0.1548 1213.8	0.1660 1242.2	0.1760 1267.2
3100.0	3085.3	700.31	$v_f$ $h_o$	– –	– –	0.1320 1166.2	0.1456 1202.9	0.1571 1233.0	0.1672 1259.3
3200.0	3185.3	705.11	$v_f$ $h_o$	– –	– –	0.1226 1151.1	0.1369 1191.4	0.1486 1223.5	0.1589 1251.1
3206.2	3191.5	705.40	$v_f$ $h_o$	– –	– –	0.1220 1150.2	0.1363 1190.6	0.1480 1222.9	0.1583 1250.5

Pressure (psi)		Saturated Temperature (°F)	$v_f, h_o$	Temperature (°F)				
Absolute	Gage			860	900	1000	1100	1200
2900.0	2885.3	690.26	$v_f$ $h_o$	0.2108 1335.3	0.2254 1369.7	0.2577 1445.1	0.2864 1512.7	0.3132 1576.5
3000.0	2985.3	695.36	$v_f$ $h_o$	0.2014 1329.7	0.2159 1365.0	0.2476 1441.8	0.2757 1510.0	0.3018 1574.3
3100.0	3085.3	700.31	$v_f$ $h_o$	0.1926 1324.1	0.2070 1360.3	0.2382 1438.4	0.2657 1507.4	0.2911 1572.1
3200.0	3185.3	705.11	$v_f$ $h_o$	0.1843 1318.3	0.1986 1355.5	0.2293 1434.9	0.2563 1504.7	0.2811 1569.9
3206.2	3191.5	705.40	$v_f$ $h_o$	0.1838 1317.9	0.1981 1355.2	0.2288 1434.7	0.2557 1504.5	0.2806 1569.8



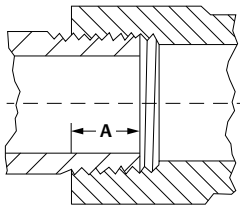
# 13

## Pipe Data

	<b>Topic</b>	<b>Page</b>
13.1	Pipe Engagement	308
13.2	Carbon and Alloy Steel — Stainless Steel	308
13.3	American Pipe Flange Dimensions	317
13.4	Cast Steel Flange Standards	322

### 13.1 Pipe Engagement

Length of thread on pipe to make a tight joint:



Nominal Pipe Size (in.)	Dimension A (in.)	Nominal Pipe Size (in.)	Dimension A (in.)
1/8	0.27	1-1/2	0.68
1/4	0.39	2	0.70
3/8	0.41	2-1/2	0.93
1/2	0.53	3	1.02
3/4	0.55	4	1.09
1	0.66	5	1.19
1-1/4	0.68	6	1.21

Dimension A is the sum of L1 (handtight engagement) and L3 (wrench makeup length for internal thread) from ASME B1.20.1-1992.

### 13.2 Carbon and Alloy Steel – Stainless Steel

Identification, wall thickness, and weights are extracted from ASME B36.10M and B36.19M. The notations STD, XS, and XXS indicate Standard, Extra Strong, and Double Extra Strong pipe, respectively. Transverse internal area values listed in ft<sup>2</sup> also represent volume in cubic feet per foot of pipe length.

Nom. Pipe Size (in.)	Nom. Dia-meter (DN)	Outside Dia-meter (in.)	Identification			Wall Thick-ness (in.)	Inside Dia-meter (d) (in.)	Area of Metal (in <sup>2</sup> )	Transverse Internal Area		Weight Pipe (lb/ft)	Water Weight (lb/ft Pipe)
			Steel		Stainless Steel Schedule				(in <sup>2</sup> )	(ft <sup>2</sup> )		
			Iron Pipe Size	Schedule								
1/8	6	0.405	–	–	10S	0.049	0.307	0.0548	0.0740	0.00051	0.19	0.032
			–	30	–	0.057	0.291	0.0623	0.0665	0.00046	0.21	0.029
			STD	40	40S	0.068	0.269	0.0720	0.0568	0.00039	0.24	0.025
			XS	80	80S	0.095	0.215	0.0925	0.0363	0.00025	0.31	0.016
1/4	8	0.540	–	–	10S	0.065	0.410	0.0970	0.1320	0.00092	0.33	0.057
			–	30	–	0.073	0.394	0.1071	0.1219	0.00085	0.36	0.053
			STD	40	40S	0.088	0.364	0.1250	0.1041	0.00072	0.42	0.045
			XS	80	80S	0.119	0.302	0.1574	0.0716	0.00050	0.54	0.031
3/8	10	0.675	–	–	10S	0.065	0.545	0.1246	0.2333	0.00162	0.42	0.101
			–	30	–	0.073	0.529	0.1381	0.2198	0.00153	0.47	0.095
			STD	40	40S	0.091	0.493	0.1670	0.1909	0.00133	0.57	0.083
			XS	80	80S	0.126	0.423	0.2173	0.1405	0.00098	0.74	0.061

# 13 – Pipe Data

## 13.2 Carbon and Alloy Steel – Stainless Steel, continued.

Nom. Pipe Size (in.)	Nom. Dia- meter (DN)	Outside Dia- meter (in.)	Identification			Wall Thick- ness (in.)	Inside Dia- meter (d) (in.)	Area of Metal (in <sup>2</sup> )	Transverse Internal Area		Weight Pipe (lb/ft)	Water Weight (lb/ft Pipe)
			Steel		Stainless Steel Schedule				(in <sup>2</sup> )	(ft <sup>2</sup> )		
			Iron Pipe Size	Schedule								
1/2	15	0.840	–	–	5S	0.065	0.710	0.1583	0.3959	0.00275	0.54	0.172
			–	–	10S	0.083	0.674	0.1974	0.3568	0.00248	0.67	0.155
			–	30	–	0.095	0.650	0.2223	0.3318	0.00230	0.76	0.144
			STD	40	40S	0.109	0.622	0.2503	0.3039	0.00211	0.85	0.132
			XS	80	80S	0.147	0.546	0.3200	0.2341	0.00163	1.09	0.101
			–	160	–	0.188	0.464	0.3851	0.1691	0.00117	1.31	0.073
			XXS	–	–	0.294	0.252	0.5043	0.0499	0.00035	1.71	0.022
3/4	20	1.050	–	–	5S	0.065	0.920	0.2011	0.6648	0.00462	0.69	0.288
			–	–	10S	0.083	0.884	0.2521	0.6138	0.00426	0.86	0.266
			–	30	–	0.095	0.860	0.2850	0.5809	0.00403	0.97	0.252
			STD	40	40S	0.113	0.824	0.3326	0.5333	0.00370	1.13	0.231
			XS	80	80S	0.154	0.742	0.4335	0.4324	0.00300	1.47	0.187
			–	160	–	0.219	0.612	0.5717	0.2942	0.00204	1.94	0.127
			XXS	–	–	0.308	0.434	0.7180	0.1479	0.00103	2.44	0.064
1	25	1.315	–	–	5S	0.065	1.185	0.2553	1.103	0.00766	0.87	0.478
			–	–	10S	0.109	1.097	0.4130	0.9452	0.00656	1.40	0.410
			–	30	–	0.114	1.087	0.4301	0.9280	0.00644	1.46	0.402
			STD	40	40S	0.133	1.049	0.4939	0.8643	0.00600	1.68	0.375
			XS	80	80S	0.179	0.957	0.6388	0.7193	0.00500	2.17	0.312
			–	160	–	0.250	0.815	0.8365	0.5217	0.00362	2.84	0.226
			XXS	–	–	0.358	0.599	1.0763	0.2818	0.00196	3.66	0.122
1-1/4	32	1.660	–	–	5S	0.065	1.530	0.3257	1.839	0.01277	1.11	0.797
			–	–	10S	0.109	1.442	0.5311	1.633	0.01134	1.81	0.708
			–	30	–	0.117	1.426	0.5672	1.597	0.01109	1.93	0.692
			STD	40	40S	0.140	1.380	0.6685	1.496	0.01039	2.27	0.648
			XS	80	80S	0.191	1.278	0.8815	1.283	0.00891	3.00	0.556
			–	160	–	0.250	1.160	1.1070	1.057	0.00734	3.76	0.458
			XXS	–	–	0.382	0.896	1.5340	0.6305	0.00438	5.21	0.273
1-1/2	40	1.900	–	–	5S	0.065	1.770	0.3747	2.461	0.01709	1.28	1.066
			–	–	10S	0.109	1.682	0.6133	2.222	0.01543	2.09	0.963
			–	30	–	0.125	1.650	0.6970	2.138	0.01485	2.37	0.927
			STD	40	40S	0.145	1.610	0.7995	2.036	0.01414	2.72	0.882
			XS	80	80S	0.200	1.500	1.068	1.767	0.01227	3.63	0.766
			–	160	–	0.281	1.338	1.429	1.406	0.00976	4.86	0.609
			XXS	–	–	0.400	1.100	1.885	0.9503	0.00660	6.41	0.412

# 13 – Pipe Data

## 13.2 Carbon and Alloy Steel – Stainless Steel, continued.

Nom. Pipe Size (in.)	Nom. Dia- meter (DN)	Outside Dia- meter (in.)	Identification			Wall Thick- ness (in.)	Inside Dia- meter (d) (in.)	Area of Metal (in <sup>2</sup> )	Transverse Internal Area		Weight Pipe (lb/ft)	Water Weight (lb/ft Pipe)
			Steel		Stainless Steel Schedule				(in <sup>2</sup> )	(ft <sup>2</sup> )		
			Iron Pipe Size	Schedule								
2	50	2.375	–	–	5S	0.065	2.245	0.4717	3.958	0.02749	1.61	1.715
			–	–	10S	0.109	2.157	0.7760	3.654	0.02538	2.64	1.583
			–	30	–	0.125	2.125	0.8836	3.547	0.02463	3.00	1.537
			STD	40	40S	0.154	2.067	1.075	3.356	0.02330	3.65	1.454
			XS	80	80S	0.218	1.939	1.477	2.953	0.02051	5.02	1.280
			–	160	–	0.344	1.687	2.195	2.235	0.01552	7.46	0.969
			XXS	–	–	0.436	1.503	2.656	1.774	0.01232	9.03	0.769
2-1/2	65	2.875	–	–	5S	0.083	2.709	0.7280	5.764	0.04003	2.48	2.498
			–	–	10S	0.120	2.635	1.039	5.453	0.03787	3.53	2.363
			–	30	–	0.188	2.499	1.587	4.905	0.03406	5.40	2.125
			STD	40	40S	0.203	2.469	1.704	4.788	0.03325	5.79	2.075
			XS	80	80S	0.276	2.323	2.254	4.238	0.02943	7.66	1.837
			–	160	–	0.375	2.125	2.945	3.547	0.02463	10.01	1.537
			XXS	–	–	0.552	1.771	4.028	2.463	0.01711	13.69	1.067
3	80	3.500	–	–	5S	0.083	3.334	0.8910	8.730	0.06063	3.03	3.783
			–	–	10S	0.120	3.260	1.274	8.347	0.05796	4.33	3.617
			30	–	–	0.188	3.124	1.956	7.665	0.05323	6.65	3.322
			STD	40	40S	0.216	3.068	2.228	7.393	0.05134	7.58	3.203
			XS	80	80S	0.300	2.900	3.016	6.605	0.04587	10.25	2.862
			–	160	–	0.438	2.624	4.213	5.408	0.03755	14.32	2.343
			XXS	–	–	0.600	2.300	5.466	4.155	0.02885	18.58	1.800
3-1/2	90	4.000	–	–	5S	0.083	3.834	1.021	11.55	0.08017	3.48	5.003
			–	–	10S	0.120	3.760	1.463	11.10	0.07711	4.97	4.812
			30	–	–	0.188	3.624	2.251	10.31	0.07163	7.65	4.470
			STD	40	40S	0.226	3.548	2.680	9.887	0.06866	9.11	4.284
			XS	80	80S	0.318	3.364	3.678	8.888	0.06172	12.50	3.851
			–	160	–	0.438	3.124	4.213	7.665	0.05323	6.65	3.322
4	100	4.500	–	–	5S	0.083	4.334	1.152	14.75	0.10245	3.92	6.393
			–	–	10S	0.120	4.260	1.651	14.25	0.09898	5.61	6.176
			–	30	–	0.188	4.124	2.547	13.36	0.09276	8.66	5.788
			STD	40	40S	0.237	4.026	3.174	12.73	0.08840	10.79	5.516
			XS	80	80S	0.337	3.826	4.407	11.50	0.07984	14.98	4.982
			–	120	–	0.438	3.624	5.589	10.31	0.07163	19.00	4.470
			–	160	–	0.531	3.438	6.621	9.283	0.06447	22.51	4.023
			XXS	–	–	0.674	3.152	8.101	7.803	0.05419	27.54	3.381

# 13 – Pipe Data

## 13.2 Carbon and Alloy Steel – Stainless Steel, continued.

Nom. Pipe Size (in.)	Nom. Dia-meter (DN)	Outside Dia-meter (in.)	Identification			Wall Thick-ness (in.)	Inside Dia-meter (d) (in.)	Area of Metal (in <sup>2</sup> )	Transverse Internal Area		Weight Pipe (lb/ft)	Water Weight (lb/ft Pipe)
			Steel		Stainless Steel Schedule				(in <sup>2</sup> )	(ft <sup>2</sup> )		
			Iron Pipe Size	Schedule								
5	125	5.563	–	–	5S	0.109	5.345	1.868	22.44	0.15582	6.36	9.723
			–	–	10S	0.134	5.295	2.285	22.02	0.15292	7.77	9.542
			STD	40	40S	0.258	5.047	4.300	20.01	0.13893	14.62	8.669
			XS	80	80S	0.375	4.813	6.112	18.19	0.12635	20.78	7.884
			–	120	–	0.500	4.563	7.953	16.35	0.11356	27.04	7.086
			–	160	–	0.625	4.313	9.696	14.61	0.10146	32.96	6.331
			XXS	–	–	0.750	4.063	11.34	12.97	0.09004	38.55	5.618
6	150	6.625	–	–	5S	0.109	6.407	2.231	32.24	0.22389	7.60	13.97
			–	–	10S	0.134	6.357	2.733	31.74	0.22041	9.29	13.75
			STD	40	40S	0.28	6.065	5.581	28.89	0.20063	18.97	12.52
			XS	80	80S	0.432	5.761	8.405	26.07	0.18102	28.57	11.30
			–	120	–	0.562	5.501	10.70	23.77	0.16505	36.39	10.30
			–	160	–	0.719	5.187	13.34	21.13	0.14674	45.35	9.157
			XXS	–	–	0.864	4.897	15.64	18.83	0.13079	53.16	8.162
8	200	8.625	–	–	5S	0.109	8.407	2.916	55.51	0.38549	9.93	24.05
			–	–	10S	0.148	8.329	3.941	54.48	0.37837	13.40	23.61
			–	20	–	0.25	8.125	6.578	51.85	0.36006	22.36	22.47
			–	30	–	0.277	8.071	7.265	51.16	0.35529	24.70	22.17
			STD	40	40S	0.322	7.981	8.399	50.03	0.34741	28.55	21.68
			–	60	–	0.406	7.813	10.48	47.94	0.33294	35.64	20.78
			XS	80	80S	0.5	7.625	12.76	45.66	0.31711	43.39	19.79
			–	100	–	0.594	7.437	14.99	43.44	0.30166	50.95	18.82
			–	120	–	0.719	7.187	17.86	40.57	0.28172	60.71	17.58
			–	140	–	0.812	7.001	19.93	38.50	0.26733	67.76	16.68
			XXS	–	–	0.875	6.875	21.30	37.12	0.25779	72.42	16.09
			–	160	–	0.906	6.813	21.97	36.46	0.25317	74.69	15.80

# 13 – Pipe Data

## 13.2 Carbon and Alloy Steel – Stainless Steel, continued.

Nom. Pipe Size (in.)	Nom. Dia-meter (DN)	Outside Dia-meter (in.)	Identification			Wall Thick-ness (in.)	Inside Dia-meter (d) (in.)	Area of Metal (in <sup>2</sup> )	Transverse Internal Area		Weight Pipe (lb/ft)	Water Weight (lb/ft Pipe)
			Steel		Stainless Steel Schedule				(in <sup>2</sup> )	(ft <sup>2</sup> )		
			Iron Pipe Size	Schedule								
10	250	10.750	–	–	5S	0.134	10.482	4.469	86.29	0.59926	15.19	37.39
			–	–	10S	0.165	10.420	5.487	85.28	0.59219	18.65	36.95
			–	20	–	0.250	10.250	8.247	82.52	0.57303	28.04	35.76
			–	30	–	0.307	10.136	10.07	80.69	0.56035	34.24	34.97
			STD	40	40S	0.365	10.020	11.91	78.85	0.54760	40.48	34.17
			XS	60	80S	0.500	9.750	16.10	74.66	0.51849	54.74	32.35
			–	80	–	0.594	9.562	18.95	71.81	0.49868	64.43	31.12
			–	100	–	0.719	9.312	22.66	68.10	0.47295	77.03	29.51
			–	120	–	0.844	9.062	26.27	64.50	0.44790	89.29	27.95
			XXS	140	–	1.000	8.750	30.63	60.13	0.41758	104.13	26.06
			–	160	–	1.125	8.500	34.02	56.75	0.39406	115.64	24.59
12	300	12.750	–	–	5S	0.156	12.438	6.172	121.5	0.84378	20.98	52.65
			–	–	10S	0.180	12.390	7.108	120.6	0.83728	24.17	52.25
			–	20	–	0.250	12.250	9.818	117.9	0.81847	33.38	51.07
			–	30	–	0.330	12.090	12.88	114.8	0.79723	43.77	49.75
			STD	–	40S	0.375	12.000	14.58	113.1	0.78540	49.56	49.01
			–	40	–	0.406	11.938	15.74	111.9	0.77731	53.52	48.50
			XS	–	80S	0.500	11.750	19.24	108.4	0.75302	65.42	46.99
			–	60	–	0.562	11.626	21.52	106.2	0.73721	73.15	46.00
			–	80	–	0.688	11.374	26.07	101.6	0.70559	88.63	44.03
			–	100	–	0.844	11.062	31.57	96.11	0.66741	107.32	41.65
			XXS	120	–	1.000	10.750	36.91	90.76	0.63030	125.49	39.33
			–	140	–	1.125	10.500	41.09	86.59	0.60132	139.67	37.52
			–	160	–	1.312	10.126	47.14	80.53	0.55925	160.27	34.90



# 13 – Pipe Data

## 13.2 Carbon and Alloy Steel – Stainless Steel, continued.

Nom. Pipe Size (in.)	Nom. Dia-meter (DN)	Outside Dia-meter (in.)	Identification			Wall Thick-ness (in.)	Inside Dia-meter (d) (in.)	Area of Metal (in <sup>2</sup> )	Transverse Internal Area		Weight Pipe (lb/ft)	Water Weight (lb/ft Pipe)
			Steel		Stainless Steel Schedule				(in <sup>2</sup> )	(ft <sup>2</sup> )		
			Iron Pipe Size	Schedule								
14	350	14.000	–	–	5S	0.156	13.688	6.785	147.2	1.02190	23.07	63.77
			–	–	10S	0.188	13.624	8.158	145.8	1.01237	27.73	63.17
			–	10	–	0.250	13.500	10.80	143.1	0.99402	36.71	62.03
			–	20	–	0.312	13.376	13.42	140.5	0.97585	45.61	60.89
			STD	30	–	0.375	13.250	16.05	137.9	0.95755	54.57	59.75
			–	40	–	0.438	13.124	18.66	135.3	0.93942	63.44	58.62
			XS	–	–	0.500	13.000	21.21	132.7	0.92175	72.09	57.52
			–	60	–	0.594	12.812	25.02	128.9	0.89529	85.05	55.87
			–	80	–	0.750	12.500	31.22	122.7	0.85221	106.13	53.18
			–	100	–	0.938	12.124	38.49	115.4	0.80172	130.85	50.03
			–	120	–	1.094	11.812	44.36	109.6	0.76098	150.79	47.49
			–	140	–	1.250	11.500	50.07	103.9	0.72131	170.21	45.01
–	160	–	1.406	11.188	55.63	98.31	0.68271	189.11	42.60			
16	400	1600	–	–	5S	0.165	15.670	8.208	192.9	1.33926	27.90	83.57
			–	–	10S	0.188	15.624	9.339	191.7	1.33141	31.75	83.08
			–	10	–	0.250	15.500	12.37	188.7	1.31036	42.05	81.77
			–	20	–	0.312	15.376	15.38	185.7	1.28948	52.27	80.46
			STD	30	–	0.375	15.250	18.41	182.7	1.26843	62.58	79.15
			XS	40	–	0.500	15.000	24.35	176.7	1.22719	82.77	76.58
			–	60	–	0.656	14.688	31.62	169.4	1.17667	107.50	73.42
			–	80	–	0.844	14.312	40.19	160.9	1.11720	136.61	69.71
			–	100	–	1.031	13.938	48.48	152.6	1.05957	164.82	66.12
			–	120	–	1.219	13.562	56.61	144.5	1.00317	192.43	62.60
			–	140	–	1.438	13.124	65.79	135.3	0.93942	223.64	58.62
			–	160	–	1.594	12.812	72.14	128.9	0.89529	245.25	55.87

# 13 – Pipe Data

## 13.2 Carbon and Alloy Steel – Stainless Steel, continued.

Nom. Pipe Size (in.)	Nom. Dia-meter (DN)	Outside Dia-meter (in.)	Identification			Wall Thick-ness (in.)	Inside Dia-meter (d) (in.)	Area of Metal (in <sup>2</sup> )	Transverse Internal Area		Weight Pipe (lb/ft)	Water Weight (lb/ft Pipe)
			Steel		Stainless Steel Schedule				(in <sup>2</sup> )	(ft <sup>2</sup> )		
			Iron Pipe Size	Schedule								
18	450	18.000	–	–	5S	0.165	17.670	9.245	245.2	1.70295	31.43	106.3
			–	–	10S	0.188	17.624	10.52	243.9	1.69409	35.76	105.7
			–	10	–	0.250	17.500	13.94	240.5	1.67034	47.39	104.2
			–	20	–	0.312	17.376	17.34	237.1	1.64675	58.94	102.8
			STD	–	–	0.375	17.250	20.76	233.7	1.62296	70.59	101.3
			–	30	–	0.438	17.124	24.17	230.3	1.59933	82.15	99.80
			XS	–	–	0.500	17.000	27.49	227.0	1.57625	93.45	98.36
			–	–40	–	0.562	16.876	30.79	223.7	1.55334	104.67	96.93
			–	60	–	0.750	16.500	40.64	213.8	1.48490	138.17	92.66
			–	80	–	0.938	16.124	50.28	204.2	1.41799	170.92	88.48
			–	100	–	1.156	15.688	61.17	193.3	1.34234	207.96	83.76
			–	120	–	1.375	15.250	71.82	182.7	1.26843	244.14	79.15
			–	140	–	1.562	14.876	80.66	173.8	1.20698	274.22	75.32
–	160	–	1.781	14.438	90.75	163.7	1.13695	308.50	70.95			
20	500	20.000	–	–	5S	0.188	19.624	11.70	302.5	2.10041	39.78	131.1
			–	–	10S	0.218	19.564	13.55	300.6	2.08758	46.06	130.3
			–	10	–	0.250	19.500	15.51	298.6	2.07395	52.73	129.4
			STD	20	–	0.375	19.250	23.12	291.0	2.02111	78.60	126.1
			XS	30	–	0.500	19.000	30.63	283.5	1.96895	104.13	122.9
			–	40	–	0.594	18.812	36.21	277.9	1.93018	123.11	120.4
			–	60	–	0.812	18.376	48.95	265.2	1.84175	166.40	114.9
			–	80	–	1.031	17.938	61.44	252.7	1.75500	208.87	109.5
			–	100	–	1.281	17.438	75.33	238.8	1.65852	256.10	103.5
			–	120	–	1.500	17.000	87.18	227.0	1.57625	296.37	98.36
			–	140	–	1.750	16.500	100.3	213.8	1.48490	341.09	92.66
			–	160	–	1.969	16.062	111.5	202.6	1.40711	379.17	87.80

# 13 – Pipe Data

## 13.2 Carbon and Alloy Steel – Stainless Steel, continued.

Nom. Pipe Size (in.)	Nom. Dia- meter (DN)	Outside Dia- meter (in.)	Identification			Wall Thick- ness (in.)	Inside Dia- meter (d) (in.)	Area of Metal (in <sup>2</sup> )	Transverse Internal Area		Weight Pipe (lb/ft)	Water Weight (lb/ft Pipe)
			Steel		Stainless Steel Schedule				(in <sup>2</sup> )	(ft <sup>2</sup> )		
			Iron Pipe Size	Schedule								
22	550	22.000	–	–	5S	0.188	21.624	12.88	367.3	2.55035	43.80	159.1
			–	–	10S	0.218	21.564	14.92	365.2	2.53622	50.71	158.3
			–	10	–	0.250	21.500	17.08	363.1	2.52119	58.07	157.3
			STD	20	–	0.375	21.250	25.48	354.7	2.46290	86.61	153.7
			XS	30	–	0.500	21.000	33.77	346.4	2.40529	114.81	150.1
			–	60	–	0.875	20.250	58.07	322.1	2.23655	197.41	139.6
			–	80	–	1.125	19.750	73.78	306.4	2.12747	250.81	132.8
			–	100	–	1.375	19.250	89.09	291.0	2.02111	302.88	126.1
			–	120	–	1.625	18.750	104.0	276.1	1.91748	353.61	119.7
			–	140	–	1.875	18.250	118.5	261.6	1.81658	403.00	113.4
			–	160	–	2.125	17.750	132.7	247.5	1.71840	451.06	107.2
24	600	24.000	–	–	5S	0.218	23.564	16.29	436.1	3.02849	55.37	189.0
			10	–	10S	0.250	23.500	18.65	433.7	3.01206	63.41	188.0
			STD	20	–	0.375	23.250	27.83	424.6	2.94832	94.62	184.0
			XS	–	–	0.500	23.000	36.91	415.5	2.88525	125.49	180.0
			–	30	–	0.562	22.876	41.38	411.0	2.85423	140.68	178.1
			–	40	–	0.688	22.624	50.39	402.0	2.79169	171.29	174.2
			–	60	–	0.969	22.062	70.11	382.3	2.65472	238.35	165.7
			–	80	–	1.219	21.562	87.24	365.1	2.53575	296.58	158.2
			–	100	–	1.531	20.938	108.1	344.3	2.39111	367.39	149.2
			–	120	–	1.812	20.376	126.3	326.1	2.26447	429.39	141.3
			–	140	–	2.062	19.876	142.1	310.3	2.15470	483.12	134.5
–	160	–	2.344	19.312	159.5	292.9	2.03415	542.13	126.9			
26	650	26.000	–	10	–	0.312	25.376	25.18	505.8	3.51216	85.60	219.2
			STD	–	–	0.375	25.250	30.19	500.7	3.47737	102.63	217.0
			XS	20	–	0.500	25.000	40.06	490.9	3.40885	136.17	212.7
28	700	28.000	–	10	–	0.312	27.376	27.14	588.6	4.08760	92.26	255.1
			STD	–	–	0.375	27.250	32.55	583.2	4.05006	110.64	252.7
			XS	20	–	0.500	27.000	43.20	572.6	3.97609	146.85	248.1
			–	30	–	0.625	26.750	53.75	562.0	3.90280	182.73	243.5
30	750	30.000	–	–	5S	0.250	29.500	23.37	683.5	4.74649	79.43	296.2
			10	–	10S	0.312	29.376	29.10	677.8	4.70667	98.93	293.7
			STD	–	–	0.375	29.250	34.90	672.0	4.66638	118.65	291.2
			XS	20	–	0.500	29.000	46.34	660.5	4.58695	157.53	286.2
			–	30	–	0.625	28.750	57.68	649.2	4.50821	196.08	281.3

# 13 – Pipe Data

## 13.2 Carbon and Alloy Steel – Stainless Steel, continued.

Nom. Pipe Size (in.)	Nom. Dia-meter (DN)	Outside Dia-meter (in.)	Identification			Wall Thick-ness (in.)	Inside Dia-meter (d) (in.)	Area of Metal (in <sup>2</sup> )	Transverse Internal Area		Weight Pipe (lb/ft)	Water Weight (lb/ft Pipe)
			Steel		Stainless Steel Schedule				(in <sup>2</sup> )	(ft <sup>2</sup> )		
			Iron Pipe Size	Schedule								
32	800	32.000	–	10	–	0.312	31.376	31.06	773.2	5.36937	105.59	335.0
			STD	–	–	0.375	31.250	37.26	767.0	5.32633	126.66	332.4
			XS	20	–	0.500	31.000	49.48	754.8	5.24145	168.21	327.1
			–	30	–	0.625	30.750	61.60	742.6	5.15726	209.43	321.8
			–	40	–	0.688	30.624	67.68	736.6	5.11508	230.08	319.2
34	850	34.000	–	10	–	0.312	33.376	33.02	874.9	6.07571	112.25	379.1
			STD	–	–	0.375	33.250	39.61	868.3	6.02992	134.67	376.3
			XS	20	–	0.500	33.000	52.62	855.3	5.93959	178.89	370.6
			–	30	–	0.625	32.750	65.53	842.4	5.84993	222.78	365.0
			–	40	–	0.688	32.624	72.00	835.9	5.80501	244.77	362.2
36	900	36.000	–	10	–	0.312	35.376	34.98	982.9	6.82568	118.92	425.9
			STD	–	–	0.375	35.250	41.97	975.9	6.77714	142.68	422.9
			XS	20	–	0.500	35.000	55.76	962.1	6.68135	189.57	416.9
			–	30	–	0.625	34.750	69.46	948.4	6.58625	236.13	411.0
			–	40	–	0.750	34.500	83.06	934.8	6.49182	282.35	405.1

## 13.3 American Pipe Flange Dimensions

### 13.3.1 Diameter of Bolt Circles

In inches per ASME B16.1, B16.5, and B16.24.

Nominal Pipe Size	Class <sup>1</sup> 125 (Cast Iron) <sup>2</sup> or Class 150 (Steel)	Class <sup>3</sup> 250 (Cast Iron) <sup>2</sup> or Class 300 (Steel)	Class 600	Class 900	Class 1500	Class 2500
1	3.12	3.50	3.50	4.00	4.00	4.25
1-1/4	3.50	3.88	3.88	4.38	4.38	5.12
1-1/2	3.88	4.50	4.50	4.88	4.88	5.75
2	4.75	5.00	5.00	6.50	6.50	6.75
2-1/2	5.50	5.88	5.88	7.50	7.50	7.75
3	6.00	6.62	6.62	7.50	8.00	9.00
4	7.50	7.88	8.50	9.25	9.50	10.75
5	8.50	9.25	10.50	11.00	11.50	12.75
6	9.50	10.62	11.50	12.50	12.50	14.50
8	11.75	13.00	13.75	15.50	15.50	17.25
10	14.25	15.25	17.00	18.50	19.00	21.75
12	17.00	17.75	19.25	21.00	22.50	24.38
14	18.75	20.25	20.75	22.00	25.00	–
16	21.25	22.50	23.75	24.25	27.75	–
18	22.75	24.75	25.75	27.00	30.50	–
20	25.00	27.00	28.50	29.50	32.75	–
24	29.50	32.00	33.00	35.50	39.00	–
30	36.00	39.25	–	–	–	–
36	42.75	46.00	–	–	–	–
42	49.50	52.75	–	–	–	–
48	56.00	60.75	–	–	–	–

1. Nominal pipe sizes 1 through 12 also apply to Class 150 cast copper alloy flanges.

2. These diameters apply to steel flanges for nominal pipe sizes 1 through 24.

3. Nominal pipe sizes 1 through 8 also apply to Class 300 cast copper alloy flanges.

### 13.3.2 Number of Stud Bolts and Diameter

In inches per ASME B16.1, B16.5, and B16.24.

Nominal Pipe Size	Class <sup>1</sup> 125 (Cast Iron) <sup>2</sup> or Class 150 (Steel)		Class <sup>3</sup> 250 (Cast Iron) <sup>2</sup> or Class 300 (Steel)		Class 600		Class 900		Class 1500		Class 2500	
	No.	D	No.	D	No.	D	No.	D	No.	D	No.	D
1	4	0.50	4	0.62	4	0.62	4	0.88	4	0.88	4	0.88
1-1/4	4	0.50	4	0.62	4	0.62	4	0.88	4	0.88	4	1.00
1-1/2	4	0.50	4	0.75	4	0.75	4	1.00	4	1.00	4	1.12
2	4	0.62	8	0.62	8	0.62	8	0.88	8	0.88	8	1.00
2-1/2	4	0.62	8	0.75	8	0.75	8	1.00	8	1.00	8	1.12
3	4	0.62	8	0.75	8	0.75	8	0.88	8	1.12	8	1.25
4	8	0.62	8	0.75	8	0.88	8	1.12	8	1.25	8	1.50
5	8	0.75	8	0.75	8	1.00	8	1.25	8	1.50	8	1.75
6	8	0.75	12	0.75	12	1.00	12	1.12	12	1.38	8	2.00
8	8	0.75	12	0.88	12	1.12	12	1.38	12	1.62	12	2.00
10	12	0.88	16	1.00	16	1.25	16	1.38	12	1.88	12	2.50
12	12	0.88	16	1.12	20	1.25	20	1.38	16	2.00	12	2.75
14	12	1.00	20	1.12	20	1.38	20	1.50	16	2.25	-	-
16	16	1.00	20	1.25	20	1.50	20	1.62	16	2.50	-	-
18	16	1.12	24	1.25	20	1.62	20	1.88	16	2.75	-	-
20	20	1.12	24	1.25	24	1.62	20	2.00	16	3.00	-	-
24	20	1.25	24	1.50	24	1.88	20	2.50	16	3.50	-	-
30	28	1.25	28	1.75	-	-	-	-	-	-	-	-
36	32	1.50	32	2.00	-	-	-	-	-	-	-	-
42	36	1.50	36	2.00	-	-	-	-	-	-	-	-
48	44	1.50	40	2.00	-	-	-	-	-	-	-	-

1. Nominal pipe sizes 1 through 12 also apply to Class 150 cast copper alloy flanges.

2. These diameters apply to steel flanges for nominal pipe sizes 1 through 24.

3. Nominal pipe sizes 1 through 8 also apply to Class 300 cast copper alloy flanges.

### 13.3.3 Flange Diameter

In inches per ASME B16.1, B16.5, and B16.24.

Nominal Pipe Size	Class <sup>1</sup> 125 (Cast Iron) <sup>2</sup> or Class 150 (Steel)	Class <sup>3</sup> 250 (Cast Iron) <sup>2</sup> or Class 300 (Steel)	Class 600	Class 900	Class 1500	Class 2500
1	4.25	4.88	4.88	5.88	5.88	6.25
1-1/4	4.62	5.25	5.25	6.25	6.25	7.25
1-1/2	5.00	6.12	6.12	7.00	7.00	8.00
2	6.00	6.50	6.50	8.50	8.50	9.25
2-1/2	7.00	7.50	7.50	9.62	9.62	10.50
3	7.50	8.25	8.25	9.50	10.50	12.00
4	9.00	10.00	10.75	11.50	12.25	14.00
5	10.00	11.00	13.00	13.75	14.75	16.50
6	11.00	12.50	14.00	15.00	15.50	19.00
8	13.50	15.00	16.50	18.50	19.00	21.75
10	16.00	17.50	20.00	21.50	23.00	26.50
12	19.00	20.50	22.00	24.00	26.50	30.00
14	21.00	23.00	23.75	25.25	29.50	–
16	23.50	25.50	27.00	27.75	32.50	–
18	25.00	28.00	29.25	31.00	36.00	–
20	27.50	30.50	32.00	33.75	38.75	–
24	32.00	36.00	37.00	41.00	46.00	–
30	38.75	43.00	–	–	–	–
36	46.00	50.00	–	–	–	–
42	53.00	57.00	–	–	–	–
48	59.50	65.00	–	–	–	–

1. Nominal pipe sizes 1 through 12 also apply to Class 150 cast copper alloy flanges.

2. Nominal pipe sizes 1 through 8 also apply to Class 300 cast copper alloy flanges.

## 13.3.4 Flange Thickness for Flange Fittings

In inches per ASME B16.1, B16.5, and B16.24. CI = cast iron, FF = flat face, and STL = steel

Nominal Pipe Size	Class 150 (CI) FF and STL	Class 150 STL	Class 150	Class 250 (CI) and Class 300 STL <sup>1</sup>	Class 300 STL	CL 300
	RF <sup>2</sup>	RTJ	Cast Copper Alloy	RF	RTJ	Cast Copper Alloy
1	0.50	0.75	0.38	0.62	0.87	0.59
1-1/4	0.56	0.81	0.41	0.69	0.94	0.62
1-1/2	0.62	0.87	0.44	0.75	1.00	0.69
2	0.69	0.94	0.50	0.81	1.12	0.75
2-1/2	0.81	1.06	0.56	0.94	1.25	0.81
3	0.88	1.13	0.62	1.06	1.37	0.91
4	0.88	1.13	0.69	1.19	1.50	1.06
5	0.88	1.13	0.75	1.31	1.62	1.12

Nominal Pipe Size	Class 600		Class 900		Class 1500		Class 2500	
	RF	RTJ	RF	RTJ	RF	RTJ	RF	RTJ
1	0.69	0.94	1.12	1.37	1.12	1.37	1.38	1.63
1-1/4	0.81	1.06	1.12	1.37	1.12	1.37	1.50	1.81
1-1/2	0.88	1.13	1.25	1.50	1.25	1.50	1.75	2.06
2	1.00	1.31	1.50	1.81	1.50	1.81	2.00	2.31
2-1/2	1.12	1.43	1.62	1.93	1.62	1.93	2.25	2.62
3	1.25	1.56	1.50	1.81	1.88	2.43	2.62	3.00
4	1.50	1.81	1.75	2.06	2.12	2.43	3.00	3.44
5	1.75	2.06	2.00	2.31	2.88	3.19	3.62	4.12



## 13.3.4 Flange Thickness for Flange Fittings, continued.

Nominal Pipe Size	Class 150 (CI) FF and STL	Class 150 STL	Class 150	Class 250 (CI) and Class 300 STL <sup>1</sup>	Class 300 STL	CL 300
	RF <sup>2</sup>	RTJ	Cast Copper Alloy	RF	RTJ	Cast Copper Alloy
6	0.94	1.19	0.81	1.38	1.69	1.19
8	1.06	1.31	0.94	1.56	1.87	1.38
10	1.12	1.37	1.00	1.81	2.12	–
12	1.19	1.44	1.06	1.94	2.25	–
14	1.31	1.56	–	2.06	2.37	–
16	1.38	1.63	–	2.19	2.50	–
18	1.50	1.75	–	2.31	2.62	–
20	1.62	1.87	–	2.44	2.82	–
24	1.81	2.06	–	2.69	3.13	–

Nominal Pipe Size	Class 600		Class 900		Class 1500		Class 2500	
	RF	RTJ	RF	RTJ	RF	RTJ	RF	RTJ
6	1.88	2.19	2.19	2.50	3.25	3.62	4.25	4.75
8	2.19	2.50	2.50	2.81	3.62	4.06	5.00	5.56
10	2.50	2.81	2.75	3.06	4.25	4.69	6.50	7.19
12	2.62	2.93	3.12	3.43	4.88	5.44	7.25	7.94
14	2.75	3.06	3.38	3.82	5.25	5.88	–	–
16	3.00	3.31	3.50	3.94	5.75	6.44	–	–
18	3.25	3.56	4.00	4.50	6.38	7.07	–	–
20	3.50	3.88	4.25	4.75	7.00	7.69	–	–
24	4.00	4.44	5.50	6.12	8.00	8.81	–	–

1. These dimensions apply to steel flanges for nominal pipe sizes 1 through 24.

2. The flange dimensions listed are for regularly furnished 0.06-in. raised face.

## 13.4 Cast Steel Flange Standards

### 13.4.1 Cast Steel Flange Standard for PN 10

DN	Flange			Bolting		
	Outside Diameter	Thickness	Bolt Circle Diameter	Number of Bolts	Threads	Bolt Hole Diameter
10	90	16	60	4	M12	14
15	95	16	65	4	M12	14
20	105	18	75	4	M12	14
25	115	18	85	4	M12	14
32	140	18	100	4	M16	18
40	150	18	110	4	M16	18
50	165	18	125	4	M16	18
65	185	18	145	8	M16	18
80	200	20	160	8	M16	18
100	220	20	180	8	M16	18
125	250	22	210	8	M16	18
150	285	22	240	8	M20	22
200	340	24	295	8	M20	22
250	395	26	350	12	M20	22
300	445	26	400	12	M20	22
350	505	26	460	16	M20	22
400	565	26	515	16	M24	26
450	615	28	565	20	M24	26
500	670	28	620	20	M24	26
600	780	30	725	20	M27	30
700	895	35	840	24	M27	30
800	1015	38	950	24	M30	33
900	1115	38	1050	28	M30	33
1000	1230	44	1160	28	M33	36
1200	1455	55	1380	32	M36	39
1400	1675	65	1590	36	M39	42
1600	1915	75	1820	40	M45	48
1800	2115	85	2020	44	M45	48
2000	2325	90	2230	48	M45	48
2200	2550	100	2440	52	M52	56
2400	2760	110	2650	56	M52	56
2600	2960	110	2850	60	M52	56
2800	3180	124	3070	64	M52	56
3000	3405	132	3290	68	M56	62

All dimensions in mm.

## 13.4.2 Cast Steel Flange Standard for PN 16

DN	Flange			Bolting		
	Outside Diameter	Thickness	Bolt Circle Diameter	Number of Bolts	Threads	Bolt Hole Diameter
10	90	16	60	4	M12	14
15	95	16	65	4	M12	14
20	105	18	75	4	M12	14
25	115	18	85	4	M12	14
32	140	18	100	4	M16	18
40	150	18	110	4	M16	18
50	165	18	125	4	M16	18
65	185	18	145	4	M16	18
80	200	20	160	8	M16	18
100	220	20	180	8	M16	18
125	250	22	210	8	M16	18
150	285	22	240	8	M20	22
200	340	24	295	12	M20	22
250	405	26	355	12	M24	26
300	460	28	410	12	M24	26
350	520	30	470	16	M24	26
400	580	32	525	16	M27	30
500	715	36	650	20	M30	33
600	840	40	770	20	M33	36
700	910	40	840	24	M33	36
800	1025	41	950	24	M36	39
900	1125	48	1050	28	M36	39
1000	1255	59	1170	28	M39	42
1200	1485	78	1390	32	M45	48
1400	1685	84	1590	36	M45	48
1600	1930	102	1820	40	M52	56
1800	2130	110	2020	44	M52	56
2000	2345	124	2230	48	M56	62

All dimensions in mm.

## 13.4.3 Cast Steel Flange Standard for PN 25

DN	Flange			Bolting		
	Outside Diameter	Thickness	Bolt Circle Diameter	Number of Bolts	Threads	Bolt Hole Diameter
10	90	16	60	4	M12	14
15	95	16	65	4	M12	14
20	105	18	75	4	M12	14
25	115	18	85	4	M12	14
32	140	18	100	4	M16	18
40	150	18	110	4	M16	18
50	165	20	125	4	M16	18
65	185	22	145	8	M16	18
80	200	24	160	8	M16	18
100	235	24	190	8	M20	22
125	270	26	220	8	M24	26
150	300	28	250	8	M24	26
200	360	30	310	12	M24	26
250	425	32	370	12	M27	30
300	485	34	430	16	M27	30
350	555	38	490	16	M30	33
400	620	40	550	16	M33	36
500	730	48	660	20	M33	36
600	845	48	770	20	M36	39
700	960	50	875	24	M39	42
800	1085	53	990	24	M45	48
900	1185	57	1090	28	M45	48
1000	1320	63	1210	28	M52	56

All dimensions in mm.

## 13.4.4 Cast Steel Flange Standard for PN 40

DN	Flange			Bolting		
	Outside Diameter	Thickness	Bolt Circle Diameter	Number of Bolts	Threads	Bolt Hole Diameter
10	90	16	60	4	M12	14
15	95	16	65	4	M12	14
20	105	18	75	4	M12	14
25	115	18	85	4	M12	14
32	140	18	100	4	M16	18
40	150	18	110	4	M16	18
50	165	20	125	4	M16	18
65	185	22	145	8	M16	18
80	200	24	160	8	M16	18
100	235	24	190	8	M20	22
125	270	26	220	8	M24	26
150	300	28	250	8	M24	26
200	375	34	320	12	M27	30
250	450	38	385	12	M30	33
300	515	42	450	16	M30	33
350	580	46	510	16	M33	36
400	660	50	585	16	M36	39
450	685	57	610	20	M36	39
500	755	57	670	20	M39	42
600	890	72	795	20	M45	48

All dimensions in mm.

### 13.4.5 Cast Steel Flange Standard for PN 63

DN	Flange			Bolting		
	Outside Diameter	Thickness	Bolt Circle Diameter	Number of Bolts	Threads	Bolt Hole Diameter
10	100	20	70	4	M12	14
15	105	20	75	4	M12	14
25	140	24	100	4	M16	18
32	155	24	110	4	M20	22
40	170	28	125	4	M20	22
50	180	26	135	4	M20	22
65	205	26	160	8	M20	22
80	215	28	170	8	M20	22
100	250	30	200	8	M24	26
125	295	34	240	8	M27	30
150	345	36	280	8	M30	33
200	415	42	345	12	M33	36
250	470	46	400	12	M33	36
300	530	52	460	16	M33	36
350	600	56	525	16	M36	39
400	670	60	585	16	M39	42

All dimensions in mm.

### 13.4.6 Cast Steel Flange Standard for PN 100

DN	Flange			Bolting		
	Outside Diameter	Thickness	Bolt Circle Diameter	Number of Bolts	Threads	Bolt Hole Diameter
10	100	20	70	4	M12	14
15	105	20	75	4	M12	14
25	140	24	100	4	M16	18
32	155	24	110	4	M20	22
40	170	28	125	4	M20	22
50	195	30	145	4	M24	26
65	220	34	170	8	M24	26
80	230	36	180	8	M24	26
100	265	40	210	8	M27	30
125	315	40	250	8	M30	33
150	355	44	290	12	M30	33
200	430	52	360	12	M33	36
250	505	60	430	12	M36	39
300	585	68	500	16	M39	42
350	655	74	560	16	M45	48

All dimensions in mm.

### 13.4.7 Cast Steel Flange Standard for PN 160

DN	Flange			Bolting		
	Outside Diameter	Thickness	Bolt Circle Diameter	Number of Bolts	Threads	Bolt Hole Diameter
10	100	20	70	4	M12	14
15	105	20	75	4	M12	14
25	140	24	100	4	M16	18
40	170	28	125	4	M20	22
50	195	30	145	4	M24	26
65	220	34	170	8	M24	26
80	230	36	180	8	M24	26
100	265	40	210	8	M27	30
125	315	44	250	8	M30	33
150	355	50	290	12	M30	33
200	430	60	360	12	M33	36
250	515	68	430	12	M39	42
300	585	78	500	16	M39	42

All dimensions in mm.

### 13.4.8 Cast Steel Flange Standard for PN 250

DN	Flange			Bolting		
	Outside Diameter	Thickness	Bolt Circle Diameter	Number of Bolts	Threads	Bolt Hole Diameter
10	125	24	85	4	M16	18
15	130	26	90	4	M16	18
25	150	28	105	4	M20	22
40	185	34	135	4	M24	26
50	200	38	150	8	M24	26
65	230	42	180	8	M24	26
80	255	46	200	8	M27	30
100	300	54	235	8	M30	33
125	340	60	275	12	M30	33
150	390	68	320	12	M33	36
200	485	82	400	12	M39	42
250	585	100	490	16	M45	48
300	690	120	590	16	M48	52

All dimensions in mm.

### 13.4.9 Cast Steel Flange Standard for PN 320

DN	Flange			Bolting		
	Outside Diameter	Thickness	Bolt Circle Diameter	Number of Bolts	Threads	Bolt Hole Diameter
10	125	24	85	4	M16	18
15	130	26	90	4	M16	18
25	160	34	115	4	M20	22
40	195	38	145	4	M24	26
50	210	42	160	8	M24	26
65	255	51	200	8	M27	30
80	275	55	220	8	M27	30
100	335	65	265	8	M33	36
125	380	75	310	12	M33	36
150	425	84	350	12	M36	39
200	525	103	440	16	M39	42
250	640	125	540	16	M48	52

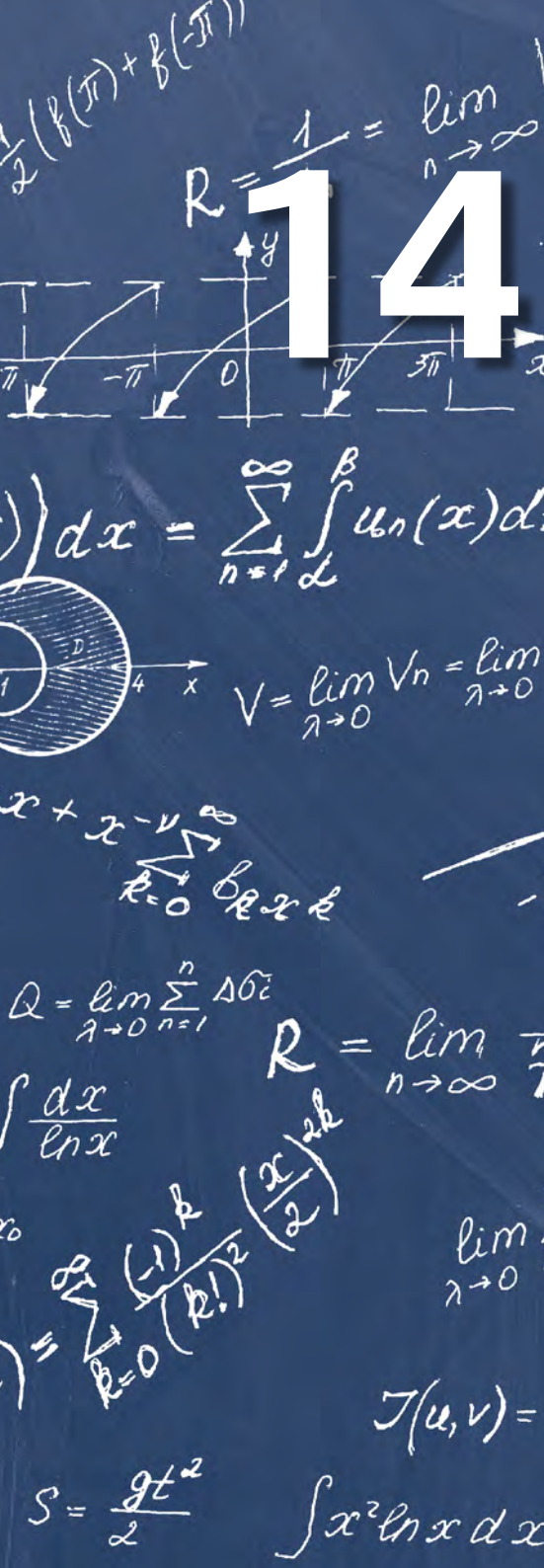
All dimensions in mm.

### 13.4.10 Cast Steel Flange Standard for PN 400

DN	Flange			Bolting		
	Outside Diameter	Thickness	Bolt Circle Diameter	Number of Bolts	Threads	Bolt Hole Diameter
10	125	28	85	4	M16	18
15	145	30	100	4	M20	22
25	180	38	130	4	M24	26
40	220	48	165	4	M27	30
50	235	52	180	8	M27	30
65	290	64	225	8	M30	33
80	305	68	240	8	M30	33
100	370	80	295	8	M36	39
125	415	92	340	12	M36	39
150	475	105	390	12	M39	42
200	585	130	490	16	M45	48

All dimensions in mm.





## Conversions and Equivalents

Topic	Page
14.1 Length Equivalents	330
14.2 Whole Inch to Millimeter Equivalents	330
14.3 Fractional Inch to Millimeter Equivalents	331
14.4 Additional Fractional Inch to Millimeter Equivalents	332
14.5 Area Equivalents	334
14.6 Volume Equivalents	334
14.7 Volume Rate Equivalents	334
14.8 Mass Conversion — Pounds to Kilograms	335
14.9 Pressure Equivalents	335
14.10 Pressure Conversion — psi to Bar	336
14.11 Temperature Conversion Formulas	337
14.12 Temperature Conversions	338
14.13 API and Baumé Gravity Tables and Weight Factors	341
14.14 Other Useful Conversions	343
14.15 Metric Prefixes and Suffixes	344

## 14.1 Length Equivalents

<i>Note: Use multiplier at convergence of row and column</i>	Meters	Inches	Feet	Millimeters	Miles	Kilometers
Meters	1	39.37	3.2808	1000	0.0006214	0.001
Inches	0.0254	1	0.0833	25.4	0.00001578	0.0000254
Feet	0.3048	12	1	304.8	0.0001894	0.0003048
Millimeters	0.001	0.03937	0.0032808	1	6.2137e-7	0.000001
Miles	1609.35	63,360	5,280	1.6093e6	1	1.60935
Kilometers	1,000	39,370	3280.83	1,000,000	0.62137	1

1 meter = 100 centimeters = 1000 millimeters = 0.001 kilometers = 1,000,000 micrometers.

To convert metric units, adjust the decimal point: 1 millimeter = 1000 microns = 0.03937 inches = 39.37 millimeters.

## 14.2 Whole Inch to Millimeter Equivalents

Inch	0	1	2	3	4	5	6	7	8	9
	Millimeters									
0	0.0	25.4	50.8	76.2	101.6	127.0	152.4	177.8	203.2	228.6
10	254.0	279.4	304.8	330.2	355.6	381.0	406.4	431.8	457.2	482.6
20	508.0	533.4	558.8	584.2	609.6	635.0	660.4	685.8	711.2	736.6
30	762.0	787.4	812.8	838.2	863.6	889.0	914.4	939.8	965.2	990.6
40	1016.0	1041.4	1066.8	1092.2	1117.6	1143.0	1168.4	1193.8	1219.2	1244.6
50	1270.0	1295.4	1320.8	1346.2	1371.6	1397.0	1422.4	1447.8	1473.2	1498.6
60	1524.0	1549.4	1574.8	1600.2	1625.6	1651.0	1676.4	1701.8	1727.2	1752.6
70	1778.0	1803.4	1828.8	1854.2	1879.6	1905.0	1930.4	1955.8	1981.2	2006.6
80	2032.0	2057.4	2082.8	2108.2	2133.6	2159.0	2184.4	2209.8	2235.2	2260.6
90	2286.0	2311.4	2336.8	2362.2	2387.6	2413.0	2438.4	2463.8	2489.2	2514.6
100	2540.0	2565.4	2590.8	2616.2	2641.6	2667.0	2692.4	2717.8	2743.2	2768.6

Note: All values in this table are exact, based on the relation 1 in. = 25.4 mm. By manipulation of the decimal point any decimal value or multiple of an inch may be converted to its exact equivalent in millimeters.

### 14.3 Fractional Inch to Millimeter Equivalents

Inch	0	1/16	1/8	3/16	1/4	5/16	3/8	7/16
	Millimeters							
0	0.0	1.6	3.2	4.8	6.4	7.9	9.5	11.1
1	25.4	27.0	28.6	30.2	31.8	33.3	34.9	36.5
2	50.8	52.4	54.0	55.6	57.2	58.7	60.3	61.9
3	76.2	77.8	79.4	81.0	82.6	84.1	85.7	87.3
4	101.6	103.2	104.8	106.4	108.0	109.5	111.1	112.7
5	127.0	128.6	130.2	131.8	133.4	134.9	136.5	138.1
6	152.4	154.0	155.6	157.2	158.8	160.3	161.9	163.5
7	177.8	179.4	181.0	182.6	184.2	185.7	187.3	188.9
8	203.2	204.8	206.4	208.0	209.6	211.1	212.7	214.3
9	228.6	230.2	231.8	233.4	235.0	236.5	238.1	239.7
10	254.0	255.6	257.2	258.8	260.4	261.9	263.5	265.1

1 inch = 25.4 millimeters

Inch	1/2	9/16	5/8	11/16	3/4	13/16	7/8	15/16
	Millimeters							
0	12.7	14.3	15.9	17.5	19.1	20.6	22.2	23.8
1	38.1	39.7	41.3	42.9	44.5	46.0	47.6	49.2
2	63.5	65.1	66.7	68.3	69.9	71.4	73.0	74.6
3	88.9	90.5	92.1	93.7	95.3	96.8	98.4	100.0
4	114.3	115.9	117.5	119.1	120.7	122.2	123.8	125.4
5	139.7	141.3	142.9	144.5	146.1	147.6	149.2	150.8
6	165.1	166.7	168.3	169.9	171.5	173.0	174.6	176.2
7	190.5	192.1	193.7	195.3	196.9	198.4	200.0	201.6
8	215.9	217.5	219.1	220.7	222.3	223.8	225.4	227.0
9	241.3	242.9	244.5	246.1	247.7	249.2	250.8	252.4
10	266.7	268.3	269.9	271.5	273.1	274.6	276.2	277.8

1 inch = 25.4 millimeters

## 14.4 Additional Fractional Inch to Millimeter Equivalents

Inches		Millimeters
Fractions	Decimals	
	0.00394	0.1
	0.00787	0.2
	0.01	0.254
	0.01181	0.3
1/64	0.015625	0.3969
	0.01575	0.4
	0.01969	0.5
	0.02	0.508
	0.02362	0.6
	0.02756	0.7
	0.03	0.762
1/32	0.03125	0.7938
	0.0315	0.8
	0.03543	0.9
	0.03937	1.0
	0.04	1.016
3/64	0.046875	1.1906
	0.05	1.27
	0.06	1.524
1/16	0.0625	1.5875
	0.07	1.778
5/64	0.078125	1.9844
	0.07874	2.0
	0.08	2.032
	0.09	2.286
3/32	0.09375	2.3812
	0.1	2.54
7/64	0.109375	2.7781
	0.11	2.794
	0.11811	3.0
	0.12	3.048
1/8	0.125	3.175
	0.13	3.302
	0.14	3.556

Inches		Millimeters
Fractions	Decimals	
9/64	0.140625	3.5719
	0.15	3.810
5/32	0.15625	3.9688
	0.15748	4.0
	0.16	4.064
	0.17	4.318
11/64	0.171875	4.3656
	0.18	4.572
3/16	0.1875	4.7625
	0.19	4.826
	0.19685	5.0
	0.2	5.08
13/64	0.203125	5.1594
	0.21	5.334
7/32	0.21875	5.5562
	0.22	5.588
	0.23	5.842
15/64	0.234375	5.9531
	0.23622	6.0
	0.24	6.096
1/4	0.25	6.35
	0.26	6.604
17/64	0.265625	6.7469
	0.27	6.858
	0.27559	7.0
	0.28	7.112
9/32	0.28125	7.1438
	0.29	7.366
19/64	0.296875	7.5406
	0.30	7.62
	0.31	7.874
5/16	0.3125	7.9375
	0.31496	8.0
	0.32	8.128

Inches		Millimeters
Fractions	Decimals	
21/64	0.328125	8.3344
	0.33	8.382
	0.34	8.636
11/32	0.34375	8.7312
	0.35	8.89
	0.35433	9.0
23/64	0.359375	9.1281
	0.36	9.144
	0.37	9.398
3/8	0.375	9.525
	0.38	9.652
	0.39	9.906
25/64	0.390625	9.9219
	0.39370	10.0
	0.40	10.16
13/32	0.40625	10.3188
	0.41	10.414
	0.42	10.668
27/64	0.421875	10.7156
	0.43	10.922
	0.43307	11.0
7/16	0.4375	11.1125
	0.44	11.176
	0.45	11.430
29/64	0.453125	11.5094
	0.46	11.684
15/32	0.46875	11.9062
	0.47	11.938
	0.47244	12.0
	0.48	12.192
31/64	0.484375	12.3031
	0.49	12.446
1/2	0.50	12.7
	0.51	12.954
	0.51181	13.0

# 14 – Conversions and Equivalents

## 14.4 Additional Fractional Inch to Millimeter Equivalents, continued.

Inches		Millimeters
Fractions	Decimals	
33/64	0.515625	13.0969
	0.52	13.208
	0.53	13.462
17/32	0.53125	13.4938
	0.54	13.716
35/64	0.546875	13.8906
	0.55	13.970
	0.55118	14.0
	0.56	14.224
9/16	0.5625	14.2875
	0.57	14.478
37/64	0.578125	14.6844
	0.58	14.732
	0.59	14.986
	0.59055	15.0
19/32	0.59375	15.0812
	0.60	15.24
39/64	0.609375	15.4781
	0.61	15.494
	0.62	15.748
5/8	0.625	15.875
	0.62992	16.0
	0.63	16.002
	0.64	16.256
41/64	0.640625	16.2719
	0.65	16.510
21/32	0.65625	16.6688
	0.66	16.764
	0.66929	17.0
	0.67	17.018
43/64	0.671875	17.0656
	0.68	17.272
11/16	0.6875	17.4625
	0.69	17.526
	0.70	17.78

Inches		Millimeters
Fractions	Decimals	
45/64	0.703125	17.8594
	0.70866	18.0
	0.71	18.034
23/32	0.71875	18.2562
	0.72	18.288
	0.73	18.542
47/64	0.734375	18.6531
	0.74	18.796
	0.74803	19.0
3/4	0.75	19.050
	0.76	19.304
49/64	0.765625	19.4469
	0.77	19.558
	0.78	19.812
25/32	0.78125	19.8438
	0.78740	20.0
	0.79	20.066
51/64	0.796875	20.2406
	0.80	20.320
	0.81	20.574
13/16	0.8125	20.6375
	0.82	20.828
	0.82677	21.0
53/64	0.828125	21.0344
	0.83	21.082
	0.84	21.336
27/32	0.84375	21.4312
	0.85	21.590
55/64	0.859375	21.8281
	0.86	21.844
	0.86614	22.0
	0.87	22.098
7/8	0.875	22.225
	0.88	22.352
	0.89	22.606

Inches		Millimeters
Fractions	Decimals	
57/64	0.890625	22.6219
	0.90	22.860
	0.90551	23.0
29/32	0.90625	23.0188
	0.91	23.114
	0.92	23.368
59/64	0.921875	23.4156
	0.93	23.622
15/16	0.9375	23.8125
	0.94	23.876
	0.94488	24.0
	0.95	24.130
61/64	0.953125	24.2094
	0.96	24.384
31/32	0.96875	24.6062
	0.97	24.638
	0.98	24.892
	0.98425	25.0
63/64	0.984375	25.0031
	0.99	25.146
1	1.00000	25.4000

## 14.5 Area Equivalents

<i>Note: Use multiplier at convergence of row and column</i>	Square Meters	Square Inches	Square Feet	Square Miles	Square Kilometers
<b>Square Meters</b>	1	1.5500e3	10.7639	$3.861 \times 10^{-7}$	$1 \times 10^{-6}$
<b>Square Inches</b>	6.4516e-4	1	$6.944 \times 10^{-3}$	$2.491 \times 10^{-10}$	$6.452 \times 10^{-10}$
<b>Square Feet</b>	0.0929	144	1	$3.587 \times 10^{-8}$	$9.29 \times 10^{-8}$
<b>Square Miles</b>	2,589,999	–	2.7878e7	1	2.59
<b>Square Kilometers</b>	1,000,000	–	10,763,867	0.3861	1

1 square meter = 10,000 square centimeters.

1 square millimeter = 0.01 square centimeter = 0.00155 square inches.

## 14.6 Volume Equivalents

<i>Note: Use multiplier at convergence of row and column</i>	Cubic Decimeters (Liters)	Cubic Inches	Cubic Feet	U.S. Quart	U.S. Gallon	Imperial Gallon	U.S. Barrel (Petroleum)
<b>Cubic Decimeters (Liters)</b>	1	61.0234	0.03531	1.05668	0.264178	0.220083	0.00629
<b>Cubic Inches</b>	0.01639	1	$5.787 \times 10^{-4}$	0.01732	0.004329	0.003606	0.000103
<b>Cubic Feet</b>	28.317	1728	1	29.9221	7.48055	6.22888	0.1781
<b>U.S. Quart</b>	0.94636	57.75	0.03342	1	0.25	0.2082	0.00595
<b>U.S. Gallon</b>	3.78543	231	0.13368	4	1	0.833	0.02381
<b>Imperial Gallon</b>	4.54374	277.274	0.16054	4.80128	1.20032	1	0.02877
<b>U.S. Barrel (Petroleum)</b>	158.98	9702	5.6146	168	42	34.973	1

1 cubic meter = 1,000,000 cubic centimeters.

1 liter = 1000 milliliters = 1000 cubic centimeters.

## 14.7 Volume Rate Equivalents

<i>Note: Use multiplier at convergence of row and column</i>	Liters Per Minute	Cubic Meters Per Hour	Cubic Feet Per Hour	Liters Per Hour	U.S. Gallon Per Minute	U.S. Barrel Per Day
<b>Liters Per Minute</b>	1	0.06	2.1189	60	0.264178	9.057
<b>Cubic Meters Per Hour</b>	16.667	1	35.314	1000	4.403	151
<b>Cubic Feet Per Hour</b>	0.4719	0.028317	1	28.317	0.1247	4.2746
<b>Liters Per Hour</b>	0.016667	0.001	0.035314	1	0.004403	0.151
<b>U.S. Gallon Per Minute</b>	3.785	0.2273	8.0208	227.3	1	34.28
<b>U.S. Barrel Per Day</b>	0.1104	0.006624	0.23394	6.624	0.02917	1

### 14.8 Mass Conversion — Pounds to Kilograms

Pounds	0	1	2	3	4	5	6	7	8	9
	Kilograms									
0	0.00	0.45	0.91	1.36	1.81	2.27	2.72	3.18	3.63	4.08
10	4.54	4.99	5.44	5.90	6.35	6.80	7.26	7.71	8.16	8.62
20	9.07	9.53	9.98	10.43	10.89	11.34	11.79	12.25	12.70	13.15
30	13.61	14.06	14.52	14.97	15.42	15.88	16.33	16.78	17.24	17.69
40	18.14	18.60	19.05	19.50	19.96	20.41	20.87	21.32	21.77	22.23
50	22.68	23.13	23.59	24.04	24.49	24.95	25.40	25.86	26.31	26.76
60	27.22	27.67	28.12	28.58	29.03	29.48	29.94	30.39	30.84	31.30
70	31.75	32.21	32.66	33.11	33.57	34.02	34.47	34.93	35.38	35.83
80	36.29	36.74	37.20	37.65	38.10	38.56	39.01	39.46	39.92	40.37
90	40.82	41.28	41.73	42.18	42.64	43.09	43.55	44.00	44.45	44.91

### 14.9 Pressure Equivalents

<i>Note: Use multiplier at convergence of row and column</i>	Kg/cm <sup>2</sup>	Lb/in <sup>2</sup>	Atm.	Bar	In. of Hg. (@ 32 °F)	Kilo-pascals	In. of Water (@ 60 °F)	Ft. of Water (@ 60 °F)
Kg/cm <sup>2</sup>	1	14.22	0.9678	0.98067	28.96	98.067	394.05	32.84
Lb/in <sup>2</sup>	0.07031	1	0.06804	0.06895	2.036	6.895	27.7	2.309
Atm.	1.0332	14.696	1	1.01325	29.92	101.325	407.14	33.93
Bar	1.01972	14.5038	0.98692	1	29.53	100	402.156	33.513
In. of Hg.	0.03453	0.4912	0.03342	0.033864	1	3.3864	13.61	11.134
Kilopascals	0.0101972	0.145038	0.0098696	0.01	0.2953	1	4.02156	0.33513
In. of Water	0.002538	0.0361	0.002456	0.00249	0.07349	0.249	1	0.0833
Ft. of Water	0.03045	0.4332	0.02947	0.029839	0.8819	2.9839	12	1

1 ounce/in<sup>2</sup> = 0.0625 lbs./in<sup>2</sup>

## 14.10 Pressure Conversion — psi to Bar

psi	0	1	2	3	4
	Bar				
0	0.000000	0.068948	0.137895	0.206843	0.275790
10	0.689476	0.758423	0.827371	0.896318	0.965266
20	1.378951	1.447899	1.516847	1.585794	1.654742
30	2.068427	2.137375	2.206322	2.275270	2.344217
40	2.757903	2.826850	2.895798	2.964746	3.033693
50	3.447379	3.516326	3.585274	3.654221	3.723169
60	4.136854	4.205802	4.274750	4.343697	4.412645
70	4.826330	4.895278	4.964225	5.033173	5.102120
80	5.515806	5.584753	5.653701	5.722649	5.791596
90	6.205282	6.274229	6.343177	6.412124	6.481072
100	6.894757	6.963705	7.032652	7.101600	7.170548

Note: To convert to kilopascals, move decimal point two positions to right; to convert to Megapascals, move decimal point one position to left. For example, 30 psi = 2.068427 bar = 206.8427 kPa = 0.2068427 MPa.

Note: Round off decimal points to provide no more than the desired degree of accuracy.

psi	5	6	7	8	9
	Bar				
0	0.344738	0.413685	0.482633	0.551581	0.620528
10	1.034214	1.103161	1.172109	1.241056	1.310004
20	1.723689	1.792637	1.861584	1.930532	1.999480
30	2.413165	2.482113	2.551060	2.620008	2.688955
40	3.102641	3.171588	3.240536	3.309484	3.378431
50	3.792117	3.861064	3.930012	3.998959	4.067907
60	4.481592	4.550540	4.619487	4.688435	4.757383
70	5.171068	5.240016	5.308963	5.377911	5.446858
80	5.860544	5.929491	5.998439	6.067386	6.136334
90	6.550019	6.618967	6.687915	6.756862	6.825810
100	7.239495	7.308443	7.377390	7.446338	7.515285

Note: To convert to kilopascals, move decimal point two positions to right; to convert to Megapascals, move decimal point one position to left. For example, 30 psi = 2.068427 bar = 206.8427 kPa = 0.2068427 MPa.

Note: Round off decimal points to provide no more than the desired degree of accuracy.



## 14.11 Temperature Conversion Formulas

To Covert From	To	Substitute in Formula
Degrees Celsius	Degrees Fahrenheit	$(^{\circ}\text{C} \times 9/5) + 32$
Degrees Celsius	Kelvin	$(^{\circ}\text{C} + 273.16)$
Degrees Fahrenheit	Degrees Celsius	$(^{\circ}\text{F} - 32) \times 5/9$
Degrees Fahrenheit	Degrees Rankine	$(^{\circ}\text{F} + 459.69)$

## 14.12 Temperature Conversions

°F	Temperature in °F or °C to be Converted	°C	°F	Temperature in °F or °C to be Converted	°C	°F	Temperature in °F or °C to be Converted	°C
	-459.69	-273.16	-220.0	-140	-95.56	24.8	-4	-20.00
	-450	-267.78	-202.0	-130	-90.00	28.4	-2	-18.89
	-440	-262.22	-184.0	-120	-84.44	32.0	0	-17.8
	-430	-256.67	-166.0	-110	-78.89	35.6	2	-16.7
	-420	-251.11	-148.0	-100	-73.33	39.2	4	-15.6
	-410	-245.56	-139.0	-95	-70.56	42.8	6	-14.4
	-400	-240.00	-130.0	-90	-67.78	46.4	8	-13.3
	-390	-234.44	-121.0	-85	-65.00	50.0	10	-12.2
	-380	-228.89	-112.0	-80	-62.22	53.6	12	-11.1
	-370	-223.33	-103.0	-75	-59.45	57.2	14	-10.0
	-360	-217.78	-94.0	-70	-56.67	60.8	16	-8.89
	-350	-212.22	-85.0	-65	-53.89	64.4	18	-7.78
	-340	-206.67	-76.0	-60	-51.11	68.0	20	-6.67
	-330	-201.11	-67.0	-55	-48.34	71.6	22	-5.56
	-320	-195.56	-58.0	-50	-45.56	75.2	24	-4.44
	-310	-190.00	-49.0	-45	-42.78	78.8	26	-3.33
	-300	-184.44	-40.0	-40	-40.00	82.4	28	-2.22
	-290	-178.89	-36.4	-38	-38.89	86.0	30	-1.11
	-280	-173.33	-32.8	-36	-37.78	89.6	32	0
-459.69	-273.16	-169.53	-29.2	-34	-36.67	93.2	34	1.11
-457.6	-272	-168.89	-25.6	-32	-35.56	96.8	36	2.22
-454.0	-270	-167.78	-22.0	-30	-34.44	100.4	38	3.33
-436.0	-260	-162.22	-18.4	-28	-33.33	104.0	40	4.44
-418.0	-250	-156.67	-14.8	-26	-32.22	107.6	42	5.56
-400.0	-240	-151.11	-11.2	-24	-31.11	111.2	44	6.67
-382.0	-230	-145.56	-7.6	-22	-30.00	114.8	46	7.78
-364.0	-220	-140.00	-4.0	-20	-28.89	118.4	48	8.89
-346.0	-210	-134.44	-0.4	-18	-27.78	122.0	50	10.0
-328.0	-200	-128.89	3.2	-16	-26.67	125.6	52	11.1
-310.0	-190	-123.33	6.8	-14	-25.56	129.2	54	12.2
-292.0	-180	-117.78	10.4	-12	-24.44	132.8	56	13.3
-274.0	-170	-112.22	14.0	-10	-23.33	136.4	58	14.4
-256.0	-160	-106.67	17.6	-8	-22.22	140.0	60	15.6
-238.0	-150	-101.11	21.2	-6	-21.11	143.6	62	16.7

## 14 – Conversions and Equivalents

### 14.12 Temperature Conversions, continued.

°F	Temperature in °F or °C to be Converted	°C	°F	Temperature in °F or °C to be Converted	°C	°F	Temperature in °F or °C to be Converted	°C
147.2	64	17.8	500.0	260	126.7	1112.0	600	315.6
150.8	66	18.9	518.0	270	132.2	1130.0	610	321.1
154.4	68	20.0	536.0	280	137.8	1148.0	620	326.7
158.0	70	21.1	554.0	290	143.3	1166.0	630	332.2
161.6	72	22.2	572.0	300	148.9	1184.0	640	337.8
165.2	74	23.3	590.0	310	154.4	1202.0	650	343.3
168.8	76	24.4	608.0	320	160.0	1220.0	660	348.9
172.4	78	25.6	626.0	330	165.6	1238.0	670	354.4
176.0	80	26.7	644.0	340	171.1	1256.0	680	360.0
179.6	82	27.8	662.0	350	176.7	1274.0	690	365.6
183.2	84	28.9	680.0	360	182.2	1292.0	700	371.1
186.8	86	30.0	698.0	370	187.8	1310.0	710	376.7
190.4	88	31.1	716.0	380	193.3	1328.0	720	382.2
194.0	90	32.2	734.0	390	198.9	1346.0	730	387.8
197.6	92	33.3	752.0	400	204.4	1364.0	740	393.3
201.2	94	34.4	770.0	410	210.0	1382.0	750	398.9
204.8	96	35.6	788.0	420	215.6	1400.0	760	404.4
208.4	98	36.7	806.0	430	221.1	1418.0	770	410.0
212.0	100	37.8	824.0	440	226.7	1436.0	780	415.6
230.0	110	43.3	842.0	450	232.2	1454.0	790	421.1
248.0	120	48.9	860.0	460	237.8	1472.0	800	426.7
266.0	130	54.4	878.0	470	243.3	1490.0	810	432.2
284.0	140	60.0	896.0	480	248.9	1508.0	820	437.8
302.0	150	65.6	914.0	490	254.4	1526.0	830	443.3
320.0	160	71.1	932.0	500	260.0	1544.0	840	448.9
338.0	170	76.7	950.0	510	265.6	1562.0	850	454.4
356.0	180	82.2	968.0	520	271.1	1580.0	860	460.0
374.0	190	87.8	986.0	530	276.7	1598.0	870	465.6
392.0	200	93.3	1004.0	540	282.2	1616.0	880	471.1
410.0	210	98.9	1022.0	550	287.8	1634.0	890	476.7
428.0	220	104.4	1040.0	560	293.3	1652.0	900	482.2
446.0	230	110.0	1058.0	570	298.9	1670.0	910	487.8
464.0	240	115.6	1076.0	580	304.4	1688.0	920	493.3
482.0	250	121.1	1094.0	590	310.0	1706.0	930	498.9

# 14 – Conversions and Equivalents

## 14.12 Temperature Conversions, continued.

°F	Temperature in °F or °C to be Converted	°C
1724.0	940	504.4
1742.0	950	510.0
1760.0	960	515.6
1778.0	970	521.1
1796.0	980	526.7
1814.0	990	532.2
1832.0	1000	537.8
1850.0	1010	543.3
1868.0	1020	548.9
1886.0	1030	554.4
1904.0	1040	560.0
1922.0	1050	565.6
1940.0	1060	571.1
1958.0	1070	576.7
1976.0	1080	582.2
1994.0	1090	587.8
2012.0	1100	593.3
2030.0	1110	598.9
2048.0	1120	604.4

°F	Temperature in °F or °C to be Converted	°C
2066.0	1130	610.0
2084.0	1140	615.6
2102.0	1150	621.1
2120.0	1160	626.7
2138.0	1170	632.2
2156.0	1180	637.8
2174.0	1190	643.3
2192.0	1200	648.9
2210.0	1210	654.4
2228.0	1220	660.0
2246.0	1230	665.6
2264.0	1240	671.1
2282.0	1250	676.7
2300.0	1260	682.2
2318.0	1270	687.8
2336.0	1280	693.3
2354.0	1290	698.9
2372.0	1300	704.4
2390.0	1310	710.0
2408.0	1320	715.6

°F	Temperature in °F or °C to be Converted	°C
2426.0	1330	721.1
2444.0	1340	726.7
2462.0	1350	732.2
2480.0	1360	737.8
2498.0	1370	743.3
2516.0	1380	748.9
2534.0	1390	754.4
2552.0	1400	760.0
2570.0	1410	765.6
2588.0	1420	771.1
2606.0	1430	776.7
2624.0	1440	782.2
2642.0	1450	787.0
2660.0	1460	793.3
2678.0	1470	798.9
2696.0	1480	804.4
2714.0	1490	810.0
2732.0	1500	815.6

## 14.13 API and Baumé Gravity Tables and Weight Factors

API Gravity	Baumé Gravity	Specific Gravity	Lb/U.S. Gravity	U.S. gal/lb	API Gravity	Baumé Gravity	Specific Gravity	Lb/U.S. Gravity	U.S. gal/lb
0	10.247	1.0760	8.962	0.1116	32	31.77	0.8654	7.206	0.1388
1	9.223	1.0679	8.895	0.1124	33	32.76	0.8602	7.163	0.1396
2	8.198	1.0599	8.828	0.1133	34	33.75	0.8550	7.119	0.1405
3	7.173	1.0520	8.762	0.1141	35	34.73	0.8498	7.076	0.1413
4	6.148	1.0443	8.698	0.1150	36	35.72	0.8448	7.034	0.1422
5	5.124	1.0366	8.634	0.1158	37	36.71	0.8398	6.993	0.1430
6	4.099	1.0291	8.571	0.1167	38	37.70	0.8348	6.951	0.1439
7	3.074	1.0217	8.509	0.1175	39	38.69	0.8299	6.910	0.1447
8	2.049	1.0143	8.448	0.1184	40	39.68	0.8251	6.870	0.1456
9	1.025	1.0071	8.388	0.1192	41	40.67	0.8203	6.830	0.1464
10	10.00	1.0000	8.328	0.1201	42	41.66	0.8155	6.790	0.1473
11	10.99	0.9930	8.270	0.1209	43	42.65	0.8109	6.752	0.1481
12	11.98	0.9861	8.212	0.1218	44	43.64	0.8063	6.713	0.1490
13	12.97	0.9792	8.155	0.1226	45	44.63	0.8017	6.675	0.1498
14	13.96	0.9725	8.099	0.1235	46	45.62	0.7972	6.637	0.1507
15	14.95	0.9659	8.044	0.1243	47	50.61	0.7927	6.600	0.1515
16	15.94	0.9593	7.989	0.1252	48	50.60	0.7883	6.563	0.1524
17	16.93	0.9529	7.935	0.1260	49	50.59	0.7839	6.526	0.1532
18	17.92	0.9465	7.882	0.1269	50	50.58	0.7796	6.490	0.1541
19	18.90	0.9402	7.830	0.1277	51	50.57	0.7753	6.455	0.1549
20	19.89	0.9340	7.778	0.1286	52	51.55	0.7711	6.420	0.1558
21	20.88	0.9279	7.727	0.1294	53	52.54	0.7669	6.385	0.1566
22	21.87	0.9218	7.676	0.1303	54	53.53	0.7628	6.350	0.1575
23	22.86	0.9159	7.627	0.1311	55	54.52	0.7587	6.316	0.1583
24	23.85	0.9100	7.578	0.1320	56	55.51	0.7547	6.283	0.1592
25	24.84	0.9042	7.529	0.1328	57	56.50	0.7507	6.249	0.1600
26	25.83	0.8984	7.481	0.1337	58	57.49	0.7467	6.216	0.1609
27	26.82	0.8927	7.434	0.1345	59	58.48	0.7428	6.184	0.1617
28	27.81	0.8871	7.387	0.1354	60	59.47	0.7389	6.151	0.1626
29	28.80	0.8816	7.341	0.1362	61	60.46	0.7351	6.119	0.1634
30	29.79	0.8762	7.296	0.1371	62	61.45	0.7313	6.087	0.1643
31	30.78	0.8708	7.251	0.1379	63	62.44	0.7275	6.056	0.1651
					64	63.43	0.7238	6.025	0.1660

## 14.13 API and Baumé Gravity Tables and Weight Factors, continued.

API Gravity	Baumé Gravity	Specific Gravity	Lb/U.S. Gravity	U.S. gal/lb	API Gravity	Baumé Gravity	Specific Gravity	Lb/U.S. Gravity	U.S. gal/lb
65	64.42	0.7201	5.994	0.1668	83	82.23	0.6597	5.491	0.1821
66	65.41	0.7165	5.964	0.1677	84	83.22	0.6566	5.465	0.1830
67	66.40	0.7128	5.934	0.1685	85	84.20	0.6536	5.440	0.1838
68	67.39	0.7093	5.904	0.1694	86	85.19	0.6506	5.415	0.1847
69	68.37	0.7057	5.874	0.1702	87	86.18	0.6476	5.390	0.1855
70	69.36	0.7022	5.845	0.1711	88	87.17	0.6446	5.365	0.1864
71	70.35	0.6988	5.817	0.1719	89	88.16	0.6417	5.341	0.1872
72	71.34	0.6953	5.788	0.1728	90	89.15	0.6388	5.316	0.1881
73	72.33	0.6919	5.759	0.1736	91	90.14	0.6360	5.293	0.1889
74	73.32	0.6886	5.731	0.1745	92	91.13	0.6331	5.269	0.1898
75	74.31	0.6852	5.703	0.1753	93	92.12	0.6303	5.246	0.1906
76	75.30	0.6819	5.676	0.1762	94	93.11	0.6275	5.222	0.1915
77	76.29	0.6787	5.649	0.1770	95	94.10	0.6247	5.199	0.1924
78	77.28	0.6754	5.622	0.1779	96	95.09	0.6220	5.176	0.1932
79	78.27	0.6722	5.595	0.1787	97	96.08	0.6193	5.154	0.1940
80	79.26	0.6690	5.568	0.1796	98	97.07	0.6166	5.131	0.1949
81	80.25	0.6659	5.542	0.1804	99	98.06	0.6139	5.109	0.1957
82	81.24	0.6628	5.516	0.1813	100	99.05	0.6112	5.086	0.1966

The relation of degrees Baumé or API to specific gravity is expressed by the following formulas:

For liquids lighter than water:

$$\text{Degrees Baumé} = \frac{140}{G} - 130, \quad G = \frac{140}{130 + \text{degrees Baumé}}$$

$$\text{Degrees API} = \frac{141.5}{G} - 131.5, \quad G = \frac{141.5}{131.5 + \text{degrees API}}$$

For liquids heavier than water:

$$\text{Degrees Baumé} = 145 - \frac{145}{G}, \quad G = \frac{145}{145 - \text{degrees Baumé}}$$

G = specific gravity = ratio of the weight of a given volume of oil at 60 °F (15.5 °C) to the weight of the same volume of water at 60 °F (15.5 °C).

## 14 – Conversions and Equivalents

The previous tables are based on the weight of 1 gallon (U.S.) of oil with a volume of 231 in<sup>3</sup> at 60 °F (15.5 °C) in air at 760 mm pressure and 50% humidity. Assumed weight of 1 gallon of water at 60 °F (15.5 °C) in air is 8.32828 pounds.

To determine the resulting gravity by mixing oils of different gravities:

$$G(\text{mix}) = \frac{md_1 + nd_2}{m + n}$$

$G(\text{mix})$  = Specific gravity of mixture

Where:

$m$  = Volume fraction of oil of  $d_1$  density

$d_1$  = Specific gravity of  $m$  oil

$n$  = Volume fraction of oil of  $d_2$  density

$d_2$  = Specific gravity of  $n$  oil

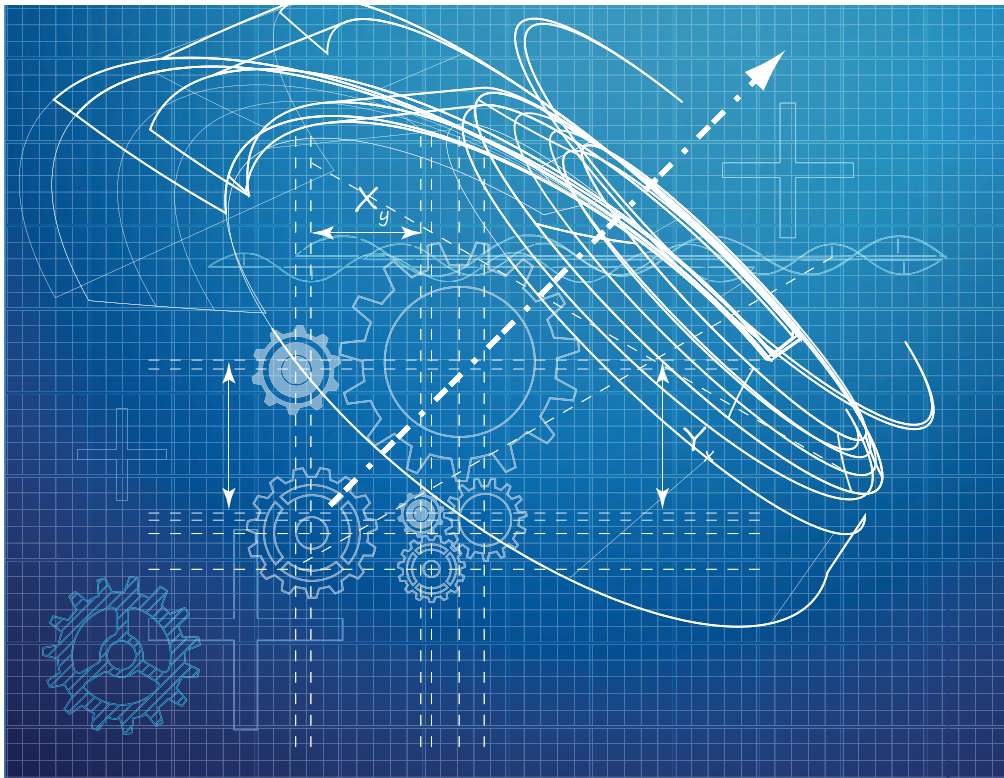
### 14.14 Other Useful Conversions

To Covert From	To	Substitute in Formula
Cu Ft (Methane)	BTU	1000 (approx.)
Cu Ft of Water	Lb of Water	62.4
Degrees	Radians	0.01745
Gal	Lb of Water	8.336
Grams	Ounces	0.0352
Horsepower (mechanical)	Ft Lb per Min	33,000
Horsepower (electrical)	Watts	746
Kg	Lb	2.205
Kg per Cu Meter	Lb per Cu Ft	0.06243
Kilowatts	Horsepower	1.341
Lb	Kg	0.4536
Lb of Air (14.7 psia and 60 °F)	Cu Ft of Air	13.1
Lb per Cu Ft	Kg per Cu Meter	16.0184
Lb per Hr (Gas)	Std Cu Ft per Hr	13.1/Specific Gravity
Lb per Hr (Water)	Gal per Min	0.002
Lb per Sec (Gas)	Std Cu Ft per Hr	0.41793/Specific Gravity
Radians	Degrees	57.3
Scfh Air	Scfh Propane	0.81
Scfh Air	Scfh Butane	0.71
Scfh Air	Scfh 0.6 Natural Gas	1.29
Scfh	Cu Meters per Hr	0.028317

## 14.15 Metric Prefixes and Suffixes

Multiplication Factor	Prefix	Symbol
1 000 000 000 000 000 000 = $10^{18}$	exa	E
1 000 000 000 000 000 = $10^{15}$	peta	P
1 000 000 000 000 = $10^{12}$	tera	T
1 000 000 000 = $10^9$	giga	G
1 000 000 = $10^6$	mega	M
1 000 = $10^3$	kilo	k
100 = $10^2$	hecto	h
10 = $10^1$	deca	da
0.1 = $10^{-1}$	deci	d
0.01 = $10^{-2}$	centi	c
0.001 = $10^{-3}$	milli	m
0.000 001 = $10^{-6}$	micro	$\mu$
0.000 000 001 = $10^{-9}$	nano	n
0.000 000 000 001 = $10^{-12}$	pico	p
0.000 000 000 000 001 = $10^{-15}$	femto	f
0.000 000 000 000 000 001 = $10^{-18}$	atto	a





The following trademarks are cited throughout these works. They are the properties of their respective owners.

- Annubar is a trademark of Emerson
- Bristol is a trademark of Remote Automation Solutions, a subsidiary of Emerson
- Coplanar is a trademark of Emerson
- ERS is a trademark of Emerson
- FOUNDATION Fieldbus is a trademark of the FieldComm Group
- HART is a registered trademark of the FieldComm Group
- Modbus is a registered trademark of Gould Inc.
- MultiVariable is a trademark of Emerson
- Pressure-Lock is a trademark of Emerson
- PROFIBUS is a registered trademark of PROFINET International (PI)
- Rosemount is a trademark of Emerson
- Saturn is a trademark of Emerson
- SuperModule is a trademark of Emerson
- THUM Adapter is a trademark of Emerson
- *WirelessHART* is a registered trademark of the FieldComm Group

## Glossary

### A

#### **Accuracy**

The closeness of agreement of the meter reading to a known value.

#### **Actual Volumetric Flow**

The flow rate of a fluid in units of volume per time where the volume is at flowing conditions.

#### **AGA**

An acronym for American Gas Association, which is an American trade organization representing natural gas producers and appliance manufacturers.

#### **Alignment Ring**

A ring that centers the meter wafer in the pipe during installation. They are made for each nominal pipe size.

#### **Ambient Temperature Effect**

Measurement errors that may result due to differences in electronics performance at varying temperatures.

#### **Analog Signal**

Analog 4-20 mA signal is a common form of communication between field devices and a control system. This utilizes a current loop in the wiring to transmit a measured variable, such as pressure or flow rate.

#### **Analog Trim**

Analog trim adjusts the transmitter's analog output to match the plant standard of the control loop. Specifically, it allows manipulation of the transmitter's current output at the 4 and 20 mA points by adjusting the digital to analog signal conversion.

#### **Annubar**

Rosemount Annubar™ is an Emerson trade name for an averaging pitot tube primary element.

#### **Area Meter**

A primary element where a change in the area of the flowing conduit is used to generate a differential pressure. Examples include orifice plate, Venturi tube, flow nozzle, wedge meter, and cone meter.

#### **As-Found Calibration**

The tested and recorded output of the transmitter during the verification process and prior to any adjustments being made. If any adjustments are made, the output is checked again and recorded.

#### **As-Left Calibration**

The tested and recorded output of the transmitter during the verification process after adjustments are made and the output is checked and recorded again.

#### **ASME**

An acronym for American Society of Mechanical Engineers.

#### **Averaging Pitot Tube**

A type of primary element that is similar in operation to a single point pitot tube, except that it measures velocities across the pipe diameter instead of at a single point.

### B

#### **Bernoulli's Equation**

An equation for fluid flow that states as fluid velocity increases, it results in a corresponding decrease in static pressure.

#### **Bernoulli's Principle**

As the velocity of a fluid increases, there is a simultaneous decrease in the fluid pressure (i.e., potential energy).

#### **Biplanar Manifold**

A traditional style of connecting to a pressure transmitter, this manifold style has two pressure ports on the side of the manifold, which results in a heavier connection system.

#### **Bleeding**

Action of removing unwanted air or liquid from impulse lines so that the impulse lines are filled with a single fluid phase, and measurement errors are prevented.

#### **Body (Gravitational) Energy**

Potential energy present in a mass (or object) due to its position at height. An example is a rock at the top of a hill.

## C

### **Calibrated Performance**

A differential pressure primary element that includes a calibration certificate for the specific flow element from a traceable flow calibration laboratory.

### **Calibrated Uncertainty**

The expected error or accuracy of a meter system that has had its performance verified against a known standard during the manufacturing process.

### **Calibration**

A process by which an instrument's performance is compared against a known standard to verify its capabilities and minimize errors.

### **Calibration Factor**

A correction value used to adjust the output of a meter to match the known standard it was compared against.

### **Capacitive Sensor**

A sensor consisting of two plates and a central, flexible diaphragm that is used to measure differential pressure.

### **Communication**

Communication is the transmission of information between two or more points (e.g., transmitter and controller) without alteration of sequence or structure of the information.

### **Compact Orifice Plate**

An orifice flow meter with the orifice built into a wafer that allows the installation between standard (not orifice) flanges, and incorporates the DP transmitter for a complete flow meter assembly.

### **Composite Accuracy**

Accuracy as determined by other performance values such as linearity, repeatability, and hysteresis.

### **Compressible Flow**

Flow of a fluid that changes volume depending upon the pressure of the system.

### **Concentric Sharp-Edged Orifice Plate**

Considered the standard orifice plate design, this type of orifice plate has a sharp upstream edge and commonly includes a bevel around the bore on the downstream side of the plate.

### **Conditioning Orifice Plate**

A proprietary Emerson design that includes four holes in the orifice plate rather than a single hole to provide enhanced accuracy in installations with limited straight pipe run.

### **Cone Meter**

A primary element that uses a cone-shaped body in a pipe spool to create a restriction.

### **Conical Entrance Orifice Plate**

An orifice plate design that includes a bevel on the upstream side of the plate and provides improved performance in high-viscosity liquids.

### **Continuity Equation**

An equation that states that what flows into a pipe must come out of the pipe. The flow rate is constant at any section of the pipe.

### **Coplanar Manifold**

An Emerson proprietary instrument connection design that has both pressure taps in the same plane on the bottom of the transmitter. This reduces the weight and bolting requirements of the overall instrument system.

### **Corner Tap**

The tap edge is at the orifice plate surface. They are typically used for orifice plates in smaller diameter pipes where the small orifice bore would put the vena-contracta close to the plate. They are sometimes used with a pressure-averaging piezometer, in which case they require more precision to machine.

### **Custody Transfer**

Measurement that is related to the buying and selling of the product being measured.

## D

### **Damping**

A transmitter setting that changes the transmitter response time. Higher values can smooth out variations in output readings caused by noise in the process measurement.

### **DCS**

An acronym for distributed control system.

## Developed Flow

Flow that will not change or develop further as the fluid travels down a straight pipe section. It has a stable velocity field.

## Differential Pressure (DP)

The difference in static pressure between two points in a fluid system imparted due to a restriction in the fluid conduit or pipe.

## Differential Pressure Flow Meter

A measurement system composed of a primary element (such as an orifice plate) and a secondary element (such as a DP transmitter) that allows measurement of fluid flow through a conduit.

## Differential Pressure Turndown

The differential pressure reading at the maximum flow rate divided by the differential pressure reading at the minimum flow rate.

## Digital Signal

A signal that represents the value of a parameter by coding a number using the binary system in a series of on/off pulses. A digital signal does not continuously change like an analog signal; digital signals jump directly from the on (1) to the off (0) state.

## Discharge Coefficient

A factor that accounts for the viscous losses and characterizes the behavior of the primary element as flow changes over the range of measurement.

## Drag Coefficient

A change in the flow coefficient over the operating range as a result of changes in local pressure on the surface relative to the stagnation pressure.

## Drag Port

A location for the low-pressure measurement that is located on the side of an averaging pitot tube shape.

## E

## Eccentric Orifice Plate

An orifice plate design that allows the bore to be positioned at the top or bottom of the pipe, which can prevent buildup of gases or liquids in front of the plate when multiple phases are present (such as steam with condensate).

## Engineering Assistant (EA)

An Emerson software program that can be used to configure a Rosemount MultiVariable transmitter.

## Enthalpy

A thermodynamic term referring to the total heat (energy) content of a system.

## F

## Flange-Lok Mounting

A mounting system that allows a Pak-Lok Annubar primary element to be used on a normal flanged connection port.

## Flange

A collar or rim on a pipe that attaches to other pipes or instruments.

## Flange Tap

A type of orifice tape that positions the center of the pressure tap 1 in. (25.4 mm) from the surface of the orifice plate. This is the most common tap type used with orifice flanges.

## Flanged Mounting

An Annubar primary element mounting style that uses an averaging pitot tube welded into a blind flange (e.g. ASME, DIN, or JIS) for mounting on the pipe system.

## Flo-Tap Mounting

An Annubar primary element mounting system that allows insertion or retraction of the sensor under pressure and flowing conditions.

## Flow

Fluid movement in an organized fashion from one location to another.

## Flow Coefficient

The variable that characterizes the true behavior of a flow meter and considers the effects of a real (rather than ideal) fluid in a pipe or conduit.

## Flow Computer

An electronic device that compensates the volumetric flow measurement for changes in density and other factors to arrive at a more accurate flow rate. It may also incorporate logging or totalizing functions.

## Flow Nozzle

A type of area DP flow meter that is designed as a contoured shape with a smooth entrance profile and an abrupt exit.

## Flow Rate

The volume of fluid passing through a particular point in a pipe over a specific time period.

## Flow Straightener

A device that is installed in a pipe or other conduit to correct the flow profile and improve measurement accuracy when the measurement point is located near a pipe disturbance such as an elbow.

## Fluid Density

The mass per unit volume of a fluid.

## Fluid Viscosity

A fluid's resistance to flow caused by the shearing stress within the flowing fluid and between the flowing fluid and its conduit.

## FOUNDATION™ Fieldbus

A two-way, all digital, multi-drop serial communication protocol that uses input/output (I/O) function blocks to interface with and represent the physical and information worlds.

## G

## Gas Expansion Factor

The factor, also known as expansibility, accounts for the change in the density of the gas as the flow goes through or around a meter. The factor is determined experimentally from data and is calculated using an equation.

## H

## Handheld Communicator

A portable device (sometimes known as a HART communicator) that allows local interaction and configuration of a field instrument.

## HART® (Highway Addressable Remote Transducer)

A protocol that communicates across legacy 4-20 mA instrumentation wiring by treating the 4-20 mA signal as a carrier and overlaying smart protocol communications on it.

## Housing

A part of a transmitter that protects the electronics.

## Hysteresis

The difference in readings at a set point when the set point is approached from different directions in the test cycle.

## I

## In-Situ Calibration

A calibration using known conditions. It is performed on a device after it has been installed in a process.

## Initial Force Conversion Constant

A conversion factor that equates inertial forces to body forces for the given set of units using Newton's first law of motion.

## Integrated Flow Meter

A DP flow meter that combines a primary element and a DP transmitter into a single component that is factory assembled and configured.

## Internal Energy

The energy contained within a system, and that at the most basic level is due to the movement of individual molecules.

## ISO

An acronym referring to the International Organization for Standardization, which is an industry standard-setting organization.

## K

## Kinetic Energy

The energy that an object has by virtue of being in motion. It is the work required to accelerate an object from a rest to its present velocity.

## L

## Latent Heat

The energy required to drive a phase change such as from a solid to a liquid, or liquid to a gas, without a change in temperature.

## Line Pressure Effect

Line pressure effect errors that occur when the characteristics of the sensor are altered under static pressure. This effect, which only applies to DP pressure measurement, is an error that results due to the forces of static pressure that are applied to the sensor.

## Linearity

The maximum change in meter performance over a given flow rate range. It is the maximum deviation between the average error curve and a designated straight line.

## Liquid Specific Gravity

The ratio of a substance's density to that of a standard, which is commonly water for liquids.

## Lockhart-Martinelli Number

A dimensionless factor used to measure the effect of a liquid in a gas and is calculated from the mass flow rate or volumetric flow rate.

## Low Flow Cutoff

A configuration parameter that allows a low flow point to be set so that the transmitter will output "0" below a designated measurement threshold.

## M

### Main Steam Line

The primary steam outlet from a boiler or superheater to a turbine, but it can also be applied to reheat lines from the intermediate turbine stages.

### Make Up Water

Treated water that is pumped into a boiler to replace the mass of steam leaving the boiler.

### Manifold

A device fitted with several valves that is used to isolate a pressure instrument from the process. It can also sometimes be used for venting or performing a zero trim.

### Manometer

A pressure gauge that usually has a U-shaped tube that allows liquid to rise until the pressure is balanced against the weight of the liquid. A scale measures the height difference, which is an indication of pressure.

## Mass Flow

The flow rate of a fluid in units of mass per time.

## Modbus®

A digital master-slave communication protocol. Modbus is primarily used to communicate, control, and monitor data.

## Module

A component of some transmitters that houses the pressure sensing element, and in some cases, additional electronic components.

## Multi-Hole Orifice Plate

A generic term to describe an orifice plate with multiple holes, which are designed to provide a consistent downstream flow field that is unaffected by the upstream fluid dynamics. This device reduces the amount of straight pipe required and required while still providing good performance.

## Multivariable Transmitter

A DP transmitter that can measure additional process variables including static pressure and temperature.

## N

### Non-Compressible Flow

A fluid whose density is generally unaffected by changes in pressure.

### Non-Newtonian Fluids

A fluid whose viscosity is variable based upon shear stress or applied force.

### Non-Proprietary DP Flow Primary Element

A device with a design and specification standard that is in the public domain.

### Nozzle

A device designed to control the characteristics of fluid flow as it exits or flows through a pipe.

## O

### O-Ring

A mechanical gasket designed to be seated in a groove and compressed during assembly to create a seal between two surfaces.

## **Offset Trim**

A signal point calibration method that corrects the offset of the calibration curve to a desired reference point. This is often known as a lower sensor trim, or a zero trim when the reference is zero.

## **Orifice Beta Ratio**

The ratio of the inner diameter of a pipe and the bore size of an orifice plate.

## **Orifice Bore**

The diameter of the hole in the orifice plate itself.

## **Orifice Plate**

A paddle-shaped device with a hole that is designed to be installed between flanges in a piping system and restricts fluid flow or creates a differential pressure.

## **P**

## **Paddle Style**

An orifice plate design that includes a handle.

## **Pak-Lok Mounting**

An Annubar flow meter mounting style that relies upon a packing gland for simple and efficient installation with a secure fit.

## **Percent of Reading Performance**

A performance specification in which the uncertainty of the measurement stays constant as a percent of the displayed value when flow rates change, leading to better performance.

## **Percent of Span Performance**

A performance specification in which the uncertainty of the measurement increases as the flow rate decreases, limiting a device's use over wide turndowns.

## **Permanent Pressure Loss (PPL)**

The decline in system pressure downstream of a primary element due to the fluid turbulence at that point.

## **Piezometer**

An averaging system that measures the pressure around the radius of a pipe to increase the accuracy of the measurement.

## **Piezoresistive Strain Gauge Sensor**

A silicon-based sensor that consists of an array of resistors, called a Wheatstone bridge, which is etched on a silicon substrate.

## **Pipe Blockage**

The percent of the pipe area at the measuring plane taken by the cross-sectional area of the flow sensor probe or cylinder installed at the measuring plane.

## **Pipe Inside Diameter (ID)**

The distance across the inside of the pipe from wall to wall.

## **Pipe Outside Diameter (OD)**

The distance across the pipe including the thickness of the pipe wall.

## **Pitot Tube**

A primary element design that measures the fluid velocity at a single point in a conduit.

## **Pressure**

The force applied to a surface, denoted as a force per unit area.

## **Pressure Energy**

Energy stored in a fluid due to the force applied per unit area.

## **Pressure-Lock™ Valve Technology**

A proprietary Emerson manifold valve technology with improved ease of use and retention under extreme pressure.

## **Primary Element**

A device installed in a pipe that creates a change in pressure, which is proportional to the flow rate. Examples include orifice plates, multi-hole orifice plates, averaging pitot tubes, Venturi tubes, wedge meters, cone meters, and flow nozzles.

## **Process Connection**

A type of connection, such as a manifold, impulse piping, or a primary element, used to connect a transmitter to the process.

## **PROFIBUS®**

A two-way, all digital communication protocol that is fundamentally designed to meet high-speed factory automation needs.

## Proprietary Primary Element

A device that is typically exclusive to a manufacturer and is under patent protection and/or the name of the device is under copyright.

## Prover

An on-site automated system that provides calibration to ensure flow meters in fiscal or custody transfer service remain in compliance with industry standards.

## Q

## Quadrant-Edge Orifice Plate

An orifice plate that is used for high-viscosity liquids over a wider range of flow than the conical entrance plate, with a linear discharge coefficient and a lower DP.

## R

## Radius Tap

It can be an upstream tap at 1 pipe diameter and downstream tap at  $\frac{1}{2}$  pipe diameter from the orifice plate surface. It can be installed without special flanges or machined mounting systems by welding couplings to the pipe wall at specified distances.

## Rangedown

The upper range limit of a transmitter divided by the minimum span the transmitter can be set to. For example, a transmitter with a 1000 inH<sub>2</sub>O upper range limit and a minimum span of 5 inH<sub>2</sub>O would have a rangedown of 200:1.

## Range Points

A transmitter setting that allows the limits of the transmitter measurement to be set (e.g., the 4-20 mA points).

## Rankine Cycle

A thermodynamic cycle that describes the process of generating steam and expanding it through a turbine.

## Reference Accuracy

Percent of accuracy of an instrument under controlled conditions, such as a flow laboratory.

## Repeatability

Ability of a transmitter to output the same values when operating under the same process and environmental conditions.

## Reproducibility

The statistical change in results for a meter used in different conditions, applications, or operators.

## Reynolds Number

The ratio of inertial forces to viscous fluids within a fluid.

## RTD

An acronym for Resistance Temperature Detector, which is a device that uses changes in electrical resistance to measure a temperature.

## S

## Safety Instrumented Systems (SIS)

An automated system that takes action to keep a plant safe or shut down a process when abnormal conditions are detected.

## Safety Integrity Level (SIL)

A relative level of risk reduction provided by a safety function.

## Sampling Meter

A primary element that measures the velocity profile in a pipe at either a single point (such as a pitot tube) or at multiple points (such as an averaging pitot tube).

## Saturated Steam

Steam that has just enough enthalpy (heat) to ensure that all the liquid water has turned to steam.

## Seals

A secondary diaphragm system between the transmitter isolating diaphragm and the process. Often connected to the transmitter by a filled fluid capillary, seals are used to convey a pressure signal while protecting the pressure transmitter from heat or damaging fluids.

## Secondary Element

Part of a DP flow meter that reads the DP generated by the primary element. The secondary element is typically a DP transmitter.



## Segmental Orifice Plate

An orifice plate with the hole in the shape of a half-moon to allow sediment and solids to pass through unimpeded.

## Sensitivity Factor

A measure of the impact an error for a particular parameter has on the calculated value.

## Sensor

Part of an electronic pressure transmitter, it physically responds to changes in input pressure and converts the physical movement into an electrical property, such as capacitance, voltage, inductance, or reluctance.

## Sensor Trim

An adjustment that changes the calibration curve associated with the characterization of the transmitter. A sensor trim can either change the slope or the offset of the linear characterization curve.

## Short-Form Venturi Tube

A Venturi tube that is made shorter by truncating the exit cone to about 70% of the original length. This increases the Permanent Pressure Loss somewhat, but it is small compared to other area DP meters.

## Sizing

The process of matching the most appropriate equipment and technology to the flow conditions specified in the application.

## Slope Trim

An adjustment that corrects the slope of the characterization curve using a known reference point. It is also known as the upper sensor trim.

## Span

The transmitter span is the region that the transmitter is set to measure, bound by the user set upper range value and lower range value. A transmitter set to measure 0-1000 inH<sub>2</sub>O would have a span of 1000 inH<sub>2</sub>O (1000 inH<sub>2</sub>O - 0 inH<sub>2</sub>O = 1000 inH<sub>2</sub>O).

## Specific Gravity

The ratio of the density of one substance to the density of a reference substance.

## Specific Weight

The weight due to gravitational pull of a pure or homogeneous substance per unit volume.

## Stability

A measure of a transmitter's consistency in output for a fixed input as a function of time. This is generally defined as a percent of the upper range value for a finite period of time.

## Stagnation Pressure

The pressure generated when a moving fluid is brought to rest and the motion converted to pressure without losses.

## Standard Volumetric Flow

The flow rate of a fluid in units of volume per time where the volume is at a standard or base set of conditions.

## Steam Enthalpy

The total energy (heat) in steam compared to a reference state.

## Steady State

A condition in which the variables that define the system (e.g., pressure, temperature, flow, etc.) are unchanging with respect to time.

## Straight Piping

A pipe that does not have any valves, fittings, or other disturbances along its length. Different lengths of straight pipe are required depending on the flow technology, but most require some straight pipe ahead of the meter to make an accurate measurement.

## Superheated Steam

When saturated steam flows over a surface that is hotter than the steam, heat is added and it becomes superheated. Steam can also become superheated when its pressure is reduced inside an insulated fitting such as a pressure-reducing valve/station.

## Super Module

A high-performance, pressure-sensing module that contains the primary analog electronics, characterization data values, and sensing element for Emerson's Rosemount 3051S series of transmitters.

## T

### **Thermowell**

A cylindrical fitting used to protect a temperature sensor installed in an industrial process.

### **Total Energy**

The total energy of a system. It is equal to the sum of the kinetic and potential energies.

### **Total Probable Error (TPE)**

Overall performance is defined by the Total Probable Error (TPE). TPE is the accuracy of the instrument in installed conditions. TPE is made up of three things: reference accuracy, ambient temperature effects, and line pressure effects.

### **Traditional DP Flow Meter**

A DP flow meter system consisting of a minimum of three separate components: a primary element, impulse lines, and a DP transmitter. These components are typically ordered component-by-component with parts being assembled on-site.

### **Turndown**

The ratio of the highest over the lowest flow rate that can be read within the stated flow meter performance. It is dependent on the stated accuracy, repeatability, and meter linearity.

### **Two-Phase Fluid**

A state of having gas entrained in a flowing liquid or liquid in a flowing gas. It may cause measurement error if the volume of the entrained fluid is significant enough.

## U

### **Uncalibrated Performance**

The specified accuracy of a primary element without calibration against a known standard. This term is interchangeable with Uncalibrated Uncertainty.

### **Uncalibrated Uncertainty**

The specified uncertainty of a primary element without calibration against a known standard. This term is interchangeable with Uncalibrated Performance.

### **Uncertainty**

Expresses the statistical dispersion of results from a single measured quantity. It is often used interchangeably with accuracy on product specifications, but uncertainty is the technically correct term.

### **Undeveloped Flow**

A flow profile that will continue to develop or change as it travels down a straight-pipe section.

### **Universal Style Plate**

An orifice plate without a handle that can be used in a plate holder, orifice fitting, or other device to affix it within the pipe.

### **Universal Venturi Tube**

The Universal Venturi Tube is like a short-form Venturi, but there are two entrance cone sections to keep the flow attached and the section short. The throat section and diffusing or exit cone are also shortened. This reduces the length and retains the low Permanent Pressure Loss.

## V

### **Velocity**

The speed of a fluid with a defined direction.

### **Velocity Profile**

The distribution of fluid velocities in a pipe cross section. A profile is said to be fully developed when there is a repeatable profile across the pipe.

### **Venturi Nozzle**

A Venturi meter combined with a nozzle to make a composite meter. An exit cone is attached to a flow nozzle.

### **Venturi Principle**

The difference in pressure of a fluid as it flows through a restriction is related to the area difference, or the difference in the square of the velocity at each section.

### **Venturi Tube**

A flow meter that consists of an entrance section, conical converging section, throat section, and diverging exit section. The DP is taken at taps in the entrance and throat sections and is generated by the Venturi principle.

**Verification**

A similar process to validation except that no trims or adjustments are performed on the DP flow meter system. It is simply a method that verifies that the flow meter output is within the stated accuracy range.

**Vortex Shedding**

In fluid dynamics, this refers to an oscillating flow that occurs when a fluid flows past a bluff body at certain velocities.

## W

**Wedge Meter**

An area meter that has a sloping surface on both sides of the restriction to direct the flow under the restriction, thereby minimizing the collection of entrained solids.

**Wet Gas**

A gas with a small amount of liquid present in the flow stream that can lead to measurement errors.

**Wet Leg**

A section of impulse piping filled with a heavier fluid than the process to protect the sensing element from harsh process conditions. A common wet leg system is water-filled impulse piping used in conjunction with high temperature steam.

**Wet (Quality) Steam**

Steam that has liquid content due to boiler carryover or lack of effective condensate removal.

**WirelessHART®**

A wireless protocol ideally suited for applications that involve instrumentation in hard to reach or unsafe areas.

## Z

**Zero Trim**

A single-point offset adjustment. It is a lower sensor trim (i.e., offset trim) that uses a known reference of zero DP.



**Global Headquarters**  
**Emerson Automation Solutions**  
6021 Innovation Blvd  
Shakopee, MN 55379 USA  
+1 800 999 9307 or +1 952 906 8888

**Europe Regional Office**  
**Emerson Automation Solutions**  
**Europe GmbH**  
Neuhofstrasse 19a P.O. Box 1046,  
CH 6340 Baar, Switzerland  
+41 (0) 41 768 6111

**Middle East & Africa Regional Office**  
**Emerson Automation Solutions**  
Emerson FZE P.O. Box 17033  
Jebel Ali Free Zone - South 2  
Dubai, United Arab Emirates  
+971 4 811 8100

**Asia Pacific Regional Office**  
**Emerson Automation Solutions**  
1 Pandan Crescent  
Singapore 128461  
+65 6777 8211



[Emerson.com](https://www.emerson.com)



[Facebook.com/EmersonAutomationSolutions](https://www.facebook.com/EmersonAutomationSolutions)



[LinkedIn.com/company/Emerson-Automation-Solutions](https://www.linkedin.com/company/Emerson-Automation-Solutions)



[Twitter.com/EMR\\_Automation](https://twitter.com/EMR_Automation)

The Emerson logo is a trademark and service mark of Emerson Electric Co. Brand logotype are registered trademarks of one of the Emerson family of companies. All other marks are the property of their respective owners.

© 2020 Emerson Electric Co. All rights reserved.  
00805-0100-1041 RevAA



**CONSIDER IT SOLVED™**