

# KENCO LOW FLOW METER MODELS 1618 AND 14308

## APPLICATION

The Kenco Low Flow Meter provides an accurate record of the amount of lubricating oil required to maintain a constant oil level in the crankcase of an engine or compressor. This meter has been used in gas and oil transmission services for many years.

## OPERATING PRINCIPLE

The Kenco Low Flow Meter is a positive displacement double action, single piston meter. The piston strokes and actuates a mechanical counter that registers the amount of oil flowing through the meter. Each piston stroke equals and registers 0.01 gallon of flow. There are two models available. The model 1618 with a mechanical counter only and the model 14308 with a mechanical counter and a reed switch. The 14308 reed switch is actuated by a magnet mounted onto the surface of the piston. The switch closes every other piston stroke thus completing a circuit every 0.02 gallon. The mechanical counter is immersed in oil assuring maximum wear resistance from vibration. The meter is installed in line between a Kenco oil storage tank and a Kenco oil level controller. The orientation of the meter does not matter as long as all the air is purged out.

## COMMON SPECIFICATIONS FOR MODELS 1618 AND 14308

- Flow Rate Range: 0.05 to 5 gallons per hour
- Working Pressure Range: 4.6 to 50 psig
- Mechanical Counter Range: 9999.99 gallons
- Mechanical Counter Resolution: 0.01 gallon

## SWITCH SPECIFICATIONS FOR MODEL 14308 ONLY

- Type: Hermetically Sealed Reed
- Circuitry: S.P.S.T. Normally Open
- Contact Resolution: 0.02 gallon
- Maximum Voltage: 100 VDC; 140 VAC
- Maximum Current: 0.25 Amps DC; 0.18 Amps AC
- Maximum Power: 7 Watts

## TECHNICAL DRAWING

- Switch conduit connection and 22 AWG switch leads are applicable to model 14308 only.
- Dimensions are for reference purposes only and are subject to change at any time without notice.

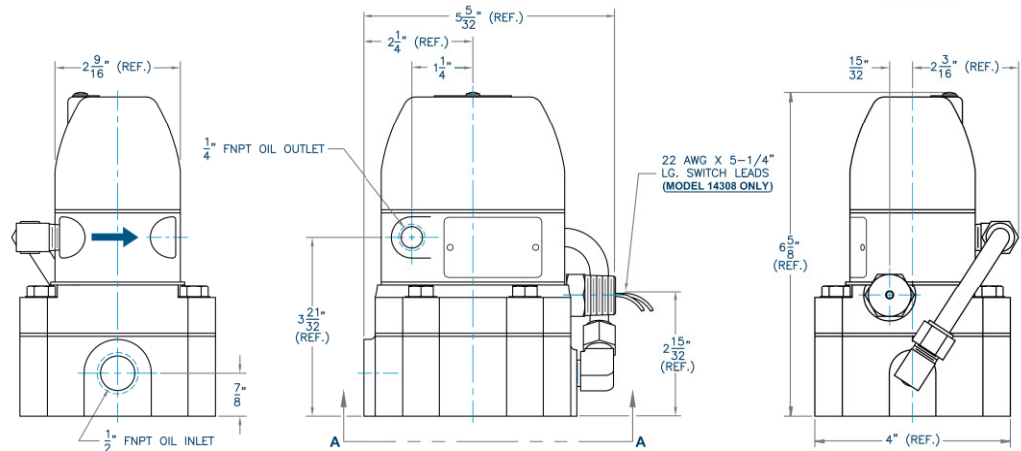

30 WT. OIL FLOW CHARACTERISTICS

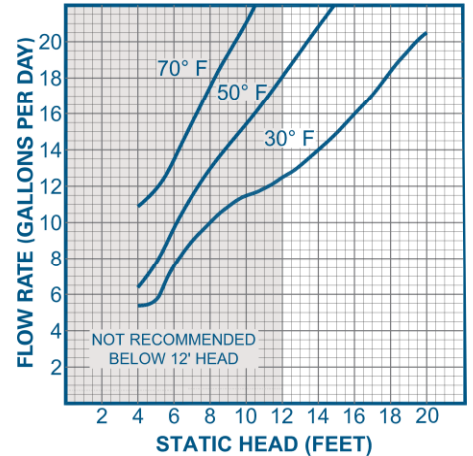

Represented by:

Kenco Sales Offices:

Headquarters

10001 E. 54th St.

Tulsa, OK 74146

phone 918.663.4406

fax 918.663.4480

www.kenco-eng.com

email: info@kenco-eng.com

Baton Rouge Office

11616 Industriplex, Suite 7

Baton Rouge, LA 70809

phone 225.755.1912

fax 225.755.1913

www.kenco-eng.com

email: kenco-la@kenco-eng.com

75029-09-06-19

