

# MGC1000 Generator Panel

The MurphyLink Series MGC1000 Panel, engineered and built by Enovation Controls' Industrial Panel Division, is a superior panel offering which includes the powerful, yet simple-to-configure MPC-10 Controller. The MPC-10 is a general, all-purpose manual/auto start engine controller. The controller is purposed primarily for applications where a wide array of inputs and outputs are not required. The MPC-10 supports J1939 CAN protocols for electronically governed engines as well as analog sensors on mechanical engines for fault and safety shutdowns.

The MPC-10 follows a standard operating sequence of machine states that happen in a predetermined order. Machine states can be set to zero if not needed or adjusted to fit the application. The menu structure is incredibly versatile, with the ability to change many parameters and settings from the face without the need of a PC tool, if desired.

The flexibility of the MPC-10 controller allows for the same control panel to be used across many applications. This provides the operator familiarity with the controller and control panel in any application.

The Control Panel utilizes industry-standard Deutsch

## Specifications

### MPC-10 Controller

Operating Voltage: 8-32 VDC, reverse polarity and load dump protected

Operating Temperature: -40° to +85° C (-40° to 185° F)

Storage Temperature: -40° to +85° C (-40° to 185° F)

### Total Current Consumption:

Power on in stopped state; 117 mA at 12 VDC. Power on in standby mode; 52 mA at 12 VDC.

### Enclosure:

Sheet Metal

### Mating Connector:

21 Position, Deutsch HDP26-24-21SE

### Communications:

- (1) CAN J1939
- (1) RS485, Modbus RTU
- (1) USB 2.0B for Programming

## How to Order

| Part Number | Model and Description  | Notes |
|-------------|--|-------|
| 75700649    | MGC1000 120 VAC Genset Panel   |       |
| 75700650    | MGC1000 240/480 VAC Genset Panel   |       |
| 75001313    | Engine (mechanical) Harness, 21 Position Connector 10' Whip Harness (3m approx.) |       |
| 40000657    | I/O Harness 12 Position Connector 5' MPC10                                       |       |
| 40000658    | E Stop PB Kit  |       |
| 78000668    | USB Programming Harness  |       |



connector and is compatible for use on the simplest mechanical engine to the most advanced, fully electronic Tier 4 engines, when used with the correct Murphy Industrial Harness<sup>1</sup> (MIH) or John Deere OEM engine harnessing.

The MGC1000 panel can be mounted directly to the engine or engine/application cover.

<sup>1</sup>Please contact Industrial Panel Sales for application specifics and MIH harnessing.

### Outputs (8):

- (2) Relays: 10A, Dedicated B+ (30 VDC @ 10A max.), 30A max aggregate @ 85C
- (2) Low-side (1A)
- (2) High-side (1A)
- (1) Dedicated Alternator Excite (provides Charge Fail Fault if unable to excite alternator)

### Inputs (9):

- (2) Digital, configurable (high/low)
- (2) Analog, configurable (4-20 mA, 0-5V, resistive)
- (1) Frequency, supporting Magnetic pickup (30 Hz - 10 kHz, 2.0 VAC-120 VAC) and Engine Alternator (30 Hz - 10 kHz, 4.5 VRMS - 90 VRMS)

### Dimensions:

4.16 x 6.083 x 10.68 in. (360 x 155 x 271mm)  
(WxHxD)

# Product and Mounting Dimensions

## MGC1000 Genset Panel

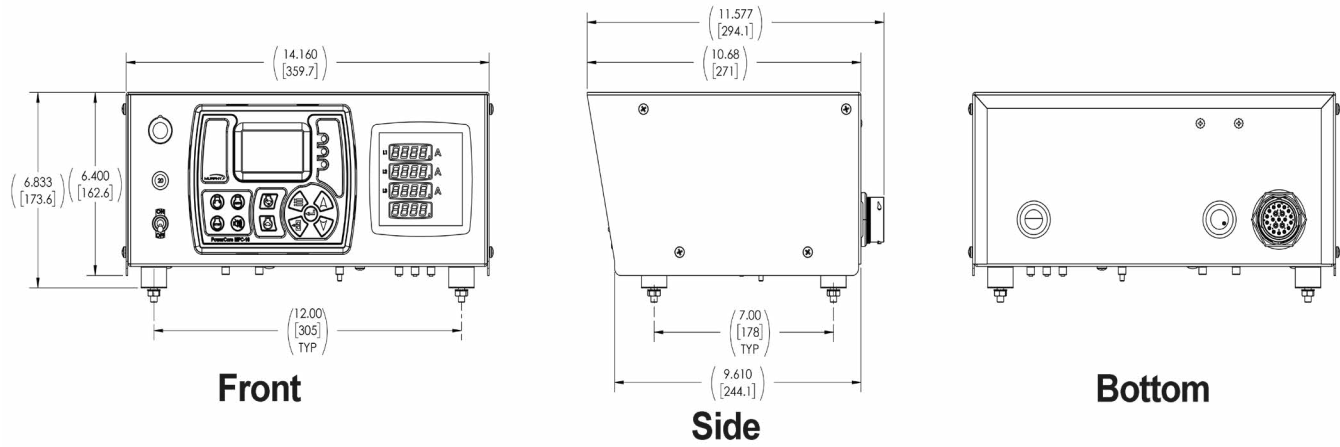

## Connector

| Deutsch 21 pin Connector Engine |                    |
|---------------------------------|--------------------|
| PIN                             | Function           |
| A                               | Reserved           |
| B                               | Battery +          |
| C                               | Reserved           |
| D                               | Starter Solenoid   |
| E                               | Battery -          |
| F                               | Reserved           |
| G                               | Fuel/ECU           |
| H                               | Reserved           |
| J                               | Alternator Excite  |
| K                               | Reserved           |
| L                               | Glowplug           |
| M                               | Reserved           |
| N                               | Reserved           |
| P                               | Reserved           |
| R                               | AUX. Output 1 (-)  |
| S                               | AUX. Output 2 (-)  |
| T                               | Frequency Input    |
| U                               | J1939 CAN LO       |
| V                               | J1939 CAN HI       |
| W                               | Temperature Sender |
| X                               | Pressure Sender    |